

## ***OWNER'S MANUAL***

Operation  
Maintenance  
Specifications

All information in this Owner's Manual is current at the time of publication. However, HYUNDAI reserves the right to make changes at any time so that our policy of continual product improvement may be carried out.

This manual applies to all models of this vehicle and includes descriptions and explanations of optional as well as standard equipment. As a result, you may find material in this manual that does not apply to your specific vehicle.

Please note that some models are equipped with Right-Hand Drive (RHD). The explanations and illustrations for some operations in RHD models are opposite of those written in this manual.

## **CAUTION: MODIFICATIONS TO YOUR HYUNDAI**

Your HYUNDAI should not be modified in any way. Such modifications may adversely affect the performance, safety or durability of your HYUNDAI and may, in addition, violate conditions of the limited warranties covering the vehicle. Certain modifications may also be in violation of regulations established by the Department of Transportation and other government agencies in your country.

## **TWO-WAY RADIO OR CELLULAR TELEPHONE INSTALLATION**

Your vehicle is equipped with electronic fuel injection and other electronic components. It is possible for an improperly installed/adjusted two-way radio or cellular telephone to adversely affect electronic systems. For this reason, we recommend that you carefully follow the radio manufacturer's instructions or consult your HYUNDAI dealer for precautionary measures or special instructions if you choose to install one of these devices.

## SAFETY AND VEHICLE DAMAGE WARNING

This manual includes information titled as DANGER, WARNING, CAUTION and NOTICE. These titles indicate the following:

### DANGER

**DANGER** indicates a hazardous situation which, if not avoided, will result in death or serious injury.

### WARNING

**WARNING** indicates a hazardous situation which, if not avoided, could result in death or serious injury.

### CAUTION

**CAUTION** indicates a hazardous situation which, if not avoided, could result in minor or moderate injury.

### **NOTICE**

**NOTICE** indicates a situation which, if not avoided, could result in vehicle damage.

## FOREWORD

Congratulations, and thank you for choosing HYUNDAI. We are pleased to welcome you to the growing number of discerning people who drive HYUNDAIs. We are very proud of the advanced engineering and high-quality construction of each HYUNDAI we build.

Your Owner's Manual will introduce you to the features and operation of your new HYUNDAI. To become familiar with your new HYUNDAI, so that you can fully enjoy it, read this Owner's Manual carefully before driving your new vehicle.

This manual contains important safety information and instructions intended to familiarize you with your vehicle's controls and safety features so you can safely operate your vehicle.

This manual also contains information on maintenance designed to enhance safe operation of the vehicle. It is recommended that all service and maintenance on your car be performed by an authorized HYUNDAI dealer. HYUNDAI dealers are prepared to provide high-quality service, maintenance and any other assistance that may be required.

This Owner's Manual should be considered a permanent part of your vehicle, and should be kept in the vehicle so you can refer to it at any time. The manual should stay with the vehicle if you sell it to provide the next owner with important operating, safety and maintenance information.

## HYUNDAI MOTOR COMPANY

### CAUTION

**Severe engine and transmission damage may result from the use of poor quality fuels and lubricants that do not meet HYUNDAI specifications. You must always use high quality fuels and lubricants that meet the specifications listed on Page 8-9 in the Vehicle Specifications section of the Owner's Manual.**

Copyright 2019 HYUNDAI Motor Company. All rights reserved. No part of this publication may be reproduced, stored in any retrieval system or transmitted in any form or by any means without the prior written permission of HYUNDAI Motor Company.



## HOW TO USE THIS MANUAL

We want to help you get the greatest possible driving pleasure from your vehicle. Your Owner's Manual can assist you in many ways. We strongly recommend that you read the entire manual. In order to minimize the chance of death or injury, you must read the WARNING and CAUTION sections in the manual.

Illustrations complement the words in this manual to best explain how to enjoy your vehicle. By reading your manual, you will learn about features, important safety information, and driving tips under various road conditions.

The general layout of the manual is provided in the Table of Contents. Use the index when looking for a specific area or subject; it has an alphabetical listing of all information in your manual.

Sections: This manual has eight chapters plus an index. Each section begins with a brief list of contents so you can tell at a glance if that section has the information you want.

Your safety, and the safety of others, is very important. This Owner's Manual provides you with many safety precautions and operating procedures. This information alerts you to potential hazards that may hurt you or others, as well as damage to your vehicle.

Safety messages found on vehicle labels and in this manual describe these hazards and what to do to avoid or reduce the risks.

Warnings and instructions contained in this manual are for your safety. Failure to follow safety warnings and instructions can lead to serious injury or death.

Throughout this manual DANGER, WARNING, CAUTION, NOTICE and the SAFETY ALERT SYMBOL will be used.



This is the safety alert symbol. It is used to alert you to potential physical injury hazards. Obey all safety messages that follow this symbol to avoid possible injury or death. The safety alert symbol precedes the signal words DANGER, WARNING and CAUTION.

### DANGER

**DANGER** indicates a hazardous situation which, if not avoided, will result in death or serious injury.

### WARNING

**WARNING** indicates a hazardous situation which, if not avoided, could result in death or serious injury.



### CAUTION

**CAUTION** indicates a hazardous situation which, if not avoided, could result in minor or moderate injury.

### NOTICE

**NOTICE** indicates a situation which, if not avoided, could result in vehicle damage.

## FUEL REQUIREMENTS

### Gasoline engine

#### *Unleaded*

#### For Europe

For the optimal vehicle performance, we recommend you use unleaded gasoline which has an octane rating of RON (Research Octane Number) 95 / AKI (Anti Knock Index) 91 or higher. (Do not use methanol blended fuels.)

You may use unleaded gasoline with an octane rating of RON 91-94 / AKI 87-90 but it may result in slight performance reduction of the vehicle.

#### Except Europe

Your new vehicle is designed to use only unleaded fuel having an Octane Rating of RON (Research Octane Number) 91 / AKI (Anti-Knock Index) 87 or higher. (Do not use methanol blended fuels.)

Your new vehicle is designed to obtain maximum performance with UNLEADED FUEL, as well as minimize exhaust emissions and spark plug fouling.



### CAUTION

**NEVER USE LEADED FUEL.** The use of leaded fuel is detrimental to the catalytic converter and will damage the engine control system's oxygen sensor and affect emission control.

**Never add any fuel system cleaning agents to the fuel tank other than what has been specified (We recommend that you consult an authorized HYUNDAI dealer for details.)**



### WARNING

- **Do not "top off" after the nozzle automatically shuts off when refueling.**
- **Always check that the fuel cap is installed securely to prevent fuel spillage in the event of an accident.**

**Leaded (if equipped)**

For some countries, your vehicle is designed to use leaded gasoline. When you are going to use leaded gasoline, we recommend that you ask an authorized HYUNDAI dealer whether leaded gasoline in your vehicle is available or not.

Octane Rating of leaded gasoline is same with unleaded one.

**Gasoline containing alcohol and methanol**

Gasohol, a mixture of gasoline and ethanol (also known as grain alcohol), and gasoline or gasohol containing methanol (also known as wood alcohol) are being marketed along with or instead of leaded or unleaded gasoline.

Do not use gasohol containing more than 10% ethanol, and do not use gasoline or gasohol containing any methanol. Either of these fuels may cause drivability problems and damage to the fuel system, engine control system and emission control system.

Discontinue using gasohol of any kind if drivability problems occur.

Vehicle damage or driveability problems may not be covered by the manufacturer's warranty if they result from the use of:

1. Gasohol containing more than 10% ethanol.
2. Gasoline or gasohol containing methanol.
3. Leaded fuel or leaded gasohol.

 **CAUTION**

**Never use gasohol which contains methanol. Discontinue use of any gasohol product which impairs drivability.**

**Other fuels**

Using fuels such as;

- Silicone (Si) contained fuel,
- MMT (Manganese, Mn) contained fuel,
- Ferrocene (Fe) contained fuel, and
- Other metallic additives contained fuels,

may cause vehicle and engine damage or cause plugging, misfiring, poor acceleration, engine stalling, catalyst melting, abnormal corrosion, life cycle reduction, etc.

Also, the Malfunction Indicator Lamp (MIL) may illuminate.

**NOTICE**

**Damage to the fuel system or performance problem caused by the use of these fuels may not be covered by your New Vehicle Limited Warranty.**

### ***Use of MTBE***

HYUNDAI recommends avoiding fuels containing MTBE (Methyl Tertiary Butyl Ether) over 15.0% vol. (Oxygen Content 2.7% weight) in your vehicle.

Fuel containing MTBE over 15.0% vol. (Oxygen Content 2.7% weight) may reduce vehicle performance and produce vapor lock or hard starting.



### **CAUTION**

**Your New Vehicle Limited Warranty may not cover damage to the fuel system and any performance problems that are caused by the use of fuels containing methanol or fuels containing MTBE (Methyl Tertiary Butyl Ether) over 15.0% vol. (Oxygen Content 2.7% weight.)**

### ***Do not use methanol***

Fuels containing methanol (wood alcohol) should not be used in your vehicle. This type of fuel can reduce vehicle performance and damage components of the fuel system, engine control system and emission control system.

### ***Fuel Additives***

HYUNDAI recommends that you use unleaded gasoline which has an octane rating of RON (Research Octane Number) 95 / AKI (Anti Knock Index) 91 or higher (for Europe) or Octane Rating of RON (Research Octane Number) 91 / AKI (Anti-Knock Index) 87 or higher (except Europe).

For customers who do not use good quality gasolines including fuel additives regularly, and have problems starting or the engine does not run smoothly, one bottle of additive added to the fuel tank according to the maintenance schedule is recommended (refer to chapter 7, "Normal Maintenance Schedule").

Additives are available from your authorized HYUNDAI dealer along with information on how to use them. Do not mix other additives.

### ***Operation in foreign countries***

If you are going to drive your vehicle in another country, be sure to:

- Observe all regulations regarding registration and insurance.
- Determine that acceptable fuel is available.

### **Diesel engine**

#### ***Diesel fuel***

Diesel engine must be operated only on commercially available diesel fuel that complies with EN 590 or comparable standard. (EN stands for "European Norm"). Do not use marine diesel fuel, heating oils, or non-approved fuel additives, as this will increase wear and cause damage to the engine and fuel system. The use of non-approved fuels and / or fuel additives will result in a limitation of your warranty rights.

Diesel fuel of above cetane 51 is used in your vehicle. If two types of diesel fuel are available, use summer or winter fuel properly according to the following temperature conditions.

- Above -5°C (23°F) ... Summer type diesel fuel.
- Below -5°C (23°F) ... Winter type diesel fuel.

Watch the fuel level in the tank very carefully : If the engine stops through fuel failure, the circuits must be completely purged to permit restarting.



#### **CAUTION**

**Do not let any gasoline or water enter the tank. This would make it necessary to drain it out and to bleed the lines to avoid jamming the injection pump and damaging the engine.**



#### **CAUTION**

**It is recommended to use the regulated automotive diesel fuel for diesel vehicle equipped with the DPF system.**

**If you use diesel fuel including high sulfur (more than 50 ppm sulfur) and unspecified additives, it can cause the DPF system to be damaged and white smoke can be emitted.**

### ***Biodiesel***

Commercially supplied Diesel blends of no more than 7% biodiesel, commonly known as "B7 Diesel" may be used in your vehicle if Biodiesel meets EN 14214 or equivalent specifications. (EN stands for "European Norm"). The use of biofuels exceeding 7% made from rapeseed methyl ester (RME), fatty acid methyl ester (FAME), vegetable oil methyl ester (VME) etc. or mixing diesel exceeding 7% with biodiesel will cause increased wear or damage to the engine and fuel system. Repair or replacement of worn or damaged components due to the use of non approved fuels will not be covered by the manufactures warranty.



### **CAUTION**

- **Never use any fuel, whether diesel, B7 biodiesel or otherwise, that fails to meet the latest petroleum industry specification.**
- **Never use any fuel additives or treatments that are not recommended or approved by the vehicle manufacturer.**

## **VEHICLE HANDLING INSTRUCTIONS**

As with other vehicles of this type, failure to operate this vehicle correctly may result in loss of control, an accident or vehicle rollover.

Specific design characteristics (higher ground clearance, track, etc.) give this vehicle a higher center of gravity than other types of vehicles. In other words they are not designed for cornering at the same speeds as conventional 2-wheel drive vehicles. Avoid sharp turns or abrupt maneuvers. Again, failure to operate this vehicle correctly may result in loss of control, an accident or vehicle rollover. **Be sure to read the "Reducing the risk of a rollover" driving guidelines, in chapter 5 of this manual.**

## VEHICLE BREAK-IN PROCESS

No special break-in period is needed. By following a few simple precautions for the first 1,000 km (600 miles) you may add to the performance, economy and life of your vehicle.

- Do not race the engine.
- While driving, keep your engine speed (rpm, or revolutions per minute) between 2,000 rpm and 4,000 rpm.
- Do not maintain a single speed for long periods of time, either fast or slow. Varying engine speed is needed to properly break-in the engine.
- Avoid hard stops, except in emergencies, to allow the brakes to seat properly.
- Don't tow a trailer during the first 2,000 km (1,200 miles) of operation.

## RETURNING USED VEHICLES (FOR EUROPE)

HYUNDAI promotes an environmentally sound treatment for end of life vehicles and offers to take back your Hyundai end of life vehicles in accordance with the European Union (EU) End of Life Vehicles Directive.

You can get detailed information from your national HYUNDAI homepage.

## TABLE OF CONTENTS

Your vehicle at a glance

1

Safety system of your vehicle

2

Convenient features of your vehicle

3

Multimedia System

4

Driving your vehicle

5

What to do in an emergency

6

Maintenance

7

Specifications & Consumer information

8

Appendix / Index

A/I



# Your vehicle at a glance

Exterior overview .....	1-2
Interior overview.....	1-5
Instrument panel overview .....	1-7
Engine compartment .....	1-9

## EXTERIOR OVERVIEW

■ Front view

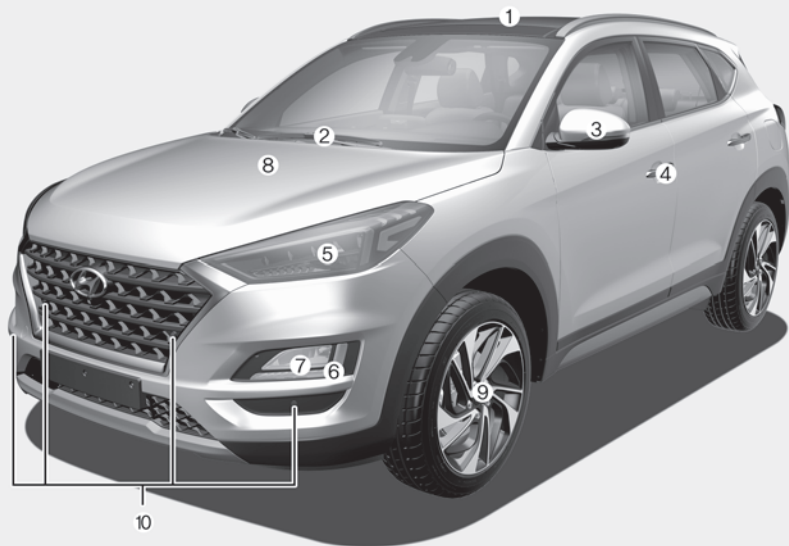

- 1. Panorama sunroof .....3-37
- 2. Front windshield wiper blades .....7-44
- 3. Outside rearview mirror .....3-29
- 4. Door locks .....3-14
- 5. Head lamp.....3-110, 7-82
- 6. DRL (Daytime Running Light) ....3-118, 7-82
- 7. Front fog lamp .....3-116, 7-86
- 8. Hood.....3-42
- 9. Tires and wheels .....7-50
- 10. Parking Distance Warning system  
(Reverse/Forward).....3-132

The actual shape may differ from the illustration.

OTLE018001

■ Front view (N line)



- 1. Panorama sunroof .....3-37
- 2. Front windshield wiper blades .....7-44
- 3. Outside rearview mirror .....3-29
- 4. Door locks .....3-14
- 5. Head lamp.....3-110, 7-82
- 6. DRL (Daytime Running Light) ....3-118, 7-82
- 7. Front fog lamp .....3-116, 7-86
- 8. Hood .....3-42
- 9. Tires and wheels .....7-50
- 10. Parking Distance Warning system  
(Reverse/Forward) .....3-132

The actual shape may differ from the illustration.

OTLEN019001

■ Rear view



- 1. Antenna .....4-3
- 2. Rear window wiper blade .....7-45
- 3. Fuel filler door .....3-44
- 4. Towing hook .....6-40
- 5. Rear combination lamp .....7-93
- 6. Tailgate .....3-47
- 7. High mounted stop lamp .....7-96
- 8. Rear View Monitor ..... 3-136
- 9. Parking Distance Warning system  
(Reverse) .....3-129

The actual shape may differ from the illustration.

OTLE018002

# INTERIOR OVERVIEW

■ Left-Hand drive type

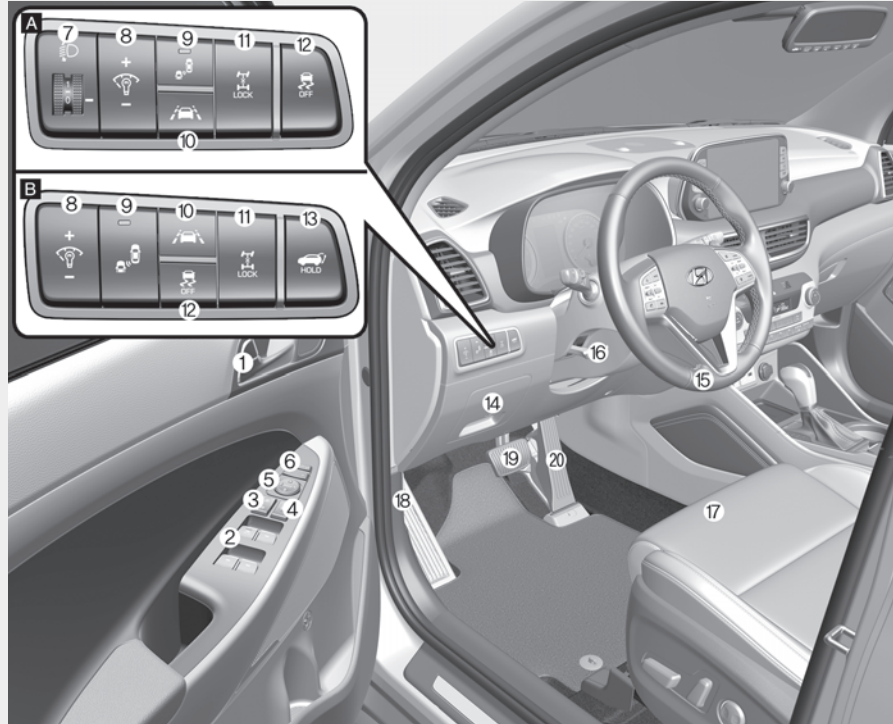

The actual shape may differ from the illustration.

- 1. Door lock/unlock button .....3-16
  - 2. Power window switches\* .....3-32
  - 3. Central door lock switch\* .....3-17
  - 4. Power window lock switch\* .....3-35
  - 5. Outside rearview mirror control switch\* .....3-30
  - 6. Outside rearview mirror folding button\* .....3-31
  - 7. Headlight leveling device\* .....3-118
  - 8. Instrument panel illumination control switch\* .....3-62
  - 9. Blind-spot Collision Warning (BCW) system\* .....5-114
  - 10. Lane Keeping Assist (LKA) system\* .....5-122, 5-131
  - 11. 4WD lock button\* .....5-67
  - 12. ESC OFF button\* .....5-58
  - 13. Power tailgate button\* .....3-49
  - 14. Fuse box .....7-67
  - 15. Steering wheel .....3-22
  - 16. Steering wheel tilt/telescope control\* .....3-23
  - 17. Seat .....2-4
  - 18. Hood release lever .....3-42
  - 19. Brake pedal .....5-43
  - 20. Accelerator pedal
- \* : if equipped

■ Right-Hand drive type

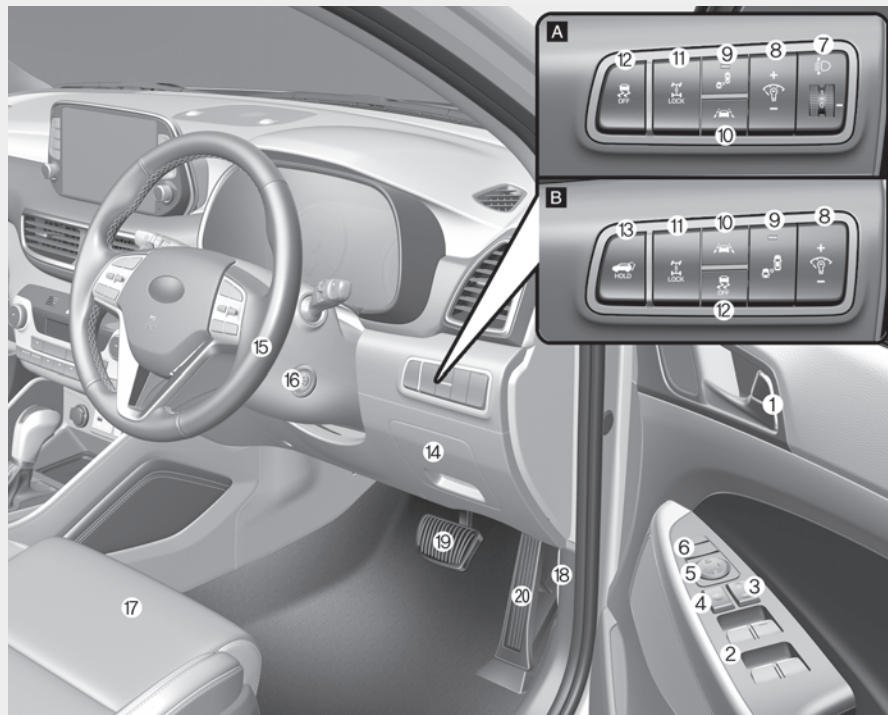

- 1. Door lock/unlock button .....3-16
  - 2. Power window switches\* .....3-32
  - 3. Central door lock switch\* .....3-17
  - 4. Power window lock switch\* .....3-35
  - 5. Outside rearview mirror control switch\* .....3-30
  - 6. Outside rearview mirror folding button\* .....3-31
  - 7. Headlight leveling device\* .....3-118
  - 8. Instrument panel illumination control switch\* .....3-62
  - 9. Blind-spot Collision Warning (BCW) system\* .....5-114
  - 10. Lane Keeping Assist (LKA) system\* .....5-122, 5-131
  - 11. 4WD lock button\* .....5-67
  - 12. ESC OFF button\* .....5-58
  - 13. Power tailgate button\* .....3-49
  - 14. Fuse box .....7-67
  - 15. Steering wheel .....3-22
  - 16. Ignition switch .....5-6
  - 17. Seat .....2-4
  - 18. Hood release lever .....3-42
  - 19. Brake pedal .....5-43
  - 20. Accelerator pedal
- \* : if equipped

The actual shape may differ from the illustration.

OTLE018003R

# INSTRUMENT PANEL OVERVIEW

■ Left-Hand drive type

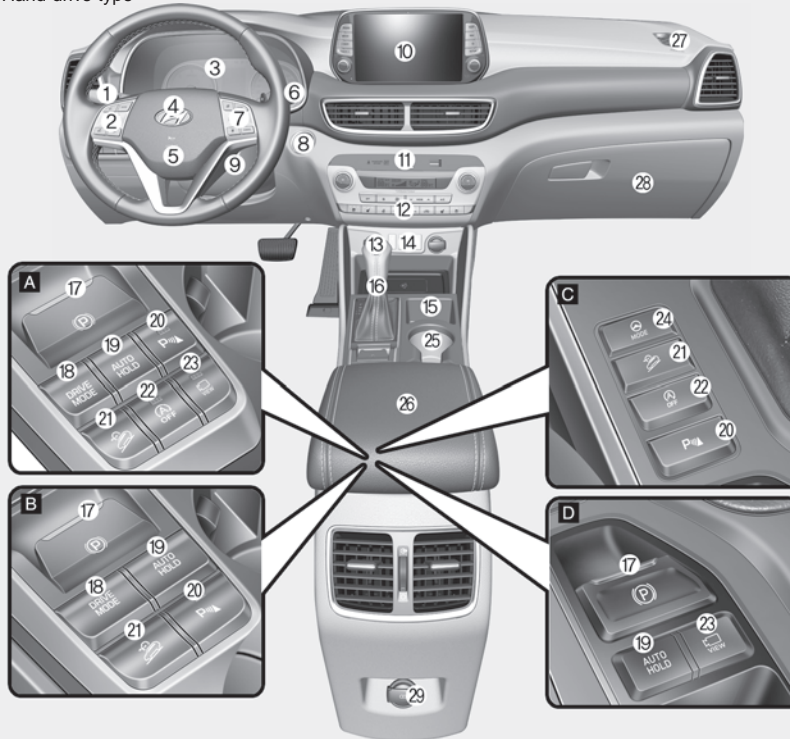

The actual shape may differ from the illustration.

1. Light control/Turn signals.....3-110
  2. Steering wheel audio controls\*.....4-4
  3. Instrument cluster.....3-60
  4. Horn.....3-24
  5. Driver's front air bag .....2-52
  6. Wiper/Washer .....3-125
  7. Auto cruise controls\* .....5-154, 5-159
  8. Engine start/stop button\* .....5-11
  9. Ignition switch .....5-6
  10. Audio/AVN\*.....4-14
  11. Hazard warning flasher switch .....6-2
  12. Climate control system\* .....3-140, 3-150
  13. Cigarette lighter\* .....3-177  
Power outlet .....3-173
  14. AUX, USB .....4-2
  15. Wireless cellular phone charging system\* .....3-175
  16. Shift lever .....5-20, 5-24, 5-31
  17. EPB switch\* .....5-46
  18. Drive mode\* .....5-84
  19. Auto hold button\* .....5-52
  20. Parking Distance Warning ON button or  
Parking Distance Warning OFF button  
.....3-130, 3-133
  21. DBC button\* .....5-64
  22. ISG OFF button\* .....5-76
  23. Surround View Monitoring system\* .....3-137
  24. Flex steering wheel\* .....5-82
  25. Cup holder. ....3-171
  26. Console box.....3-168
  27. Passenger's front air bag\* .....2-52
  28. Glove box.....3-169
  29. USB charger\* .....3-174
- \* : if equipped



■ Right-Hand drive type

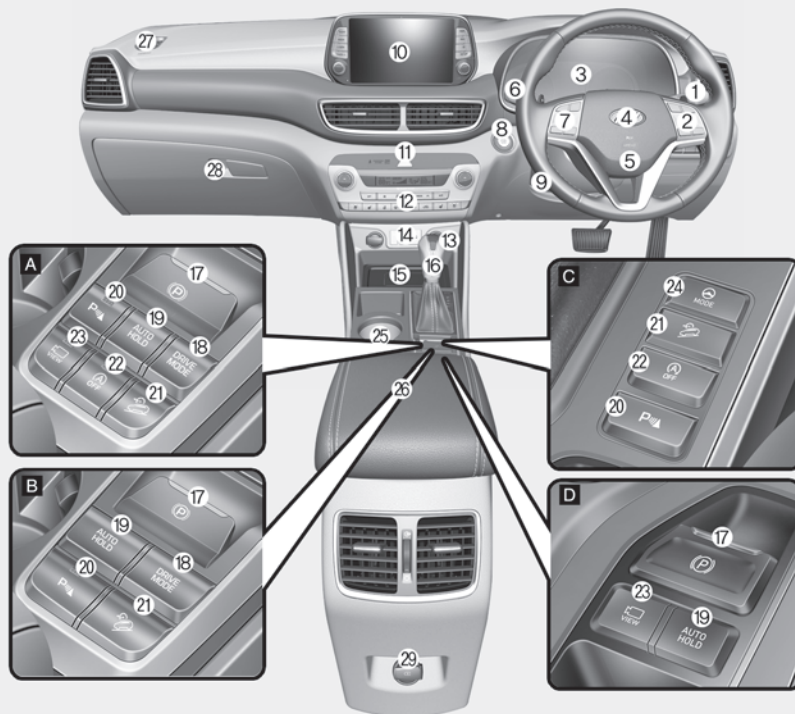

The actual shape may differ from the illustration.

1. Light control/Turn signals.....3-110
  2. Steering wheel audio controls\* .....4-4
  3. Instrument cluster .....3-60
  4. Horn .....3-24
  5. Driver's front air bag .....2-52
  6. Wiper/Washer .....3-125
  7. Auto cruise controls\* .....5-154, 5-159
  8. Engine start/stop button\* .....5-11
  9. Steering wheel tilt/telescopic lever .....3-23
  10. Audio/AVN\* .....4-14
  11. Hazard warning flasher switch .....6-2
  12. Climate control system\* .....3-140, 3-150
  13. Cigarette lighter\* .....3-177
  - Power outlet .....3-173
  14. AUX, USB .....4-2
  15. Wireless cellular phone charging system\*...3-175
  16. Shift lever .....5-20, 5-24, 5-31
  17. EPB switch\* .....5-46
  18. Drive mode\* .....5-84
  19. Auto hold button\* .....5-52
  20. Parking Distance Warning ON button or  
Parking Distance Warning OFF button  
.....3-130, 3-133
  21. DBC button\* .....5-64
  22. ISG OFF button\* .....5-76
  23. Surround View Monitoring system\* .....3-137
  24. Flex steering wheel\* .....5-82
  25. Cup holder. ....3-171
  26. Console box.....3-168
  27. Passenger's front air bag\* .....2-52
  28. Glove box.....3-169
  29. USB charger\* .....3-174
- \* : if equipped

OTLE018004R



## ENGINE COMPARTMENT

### ■ Gasoline 1.6 GDI

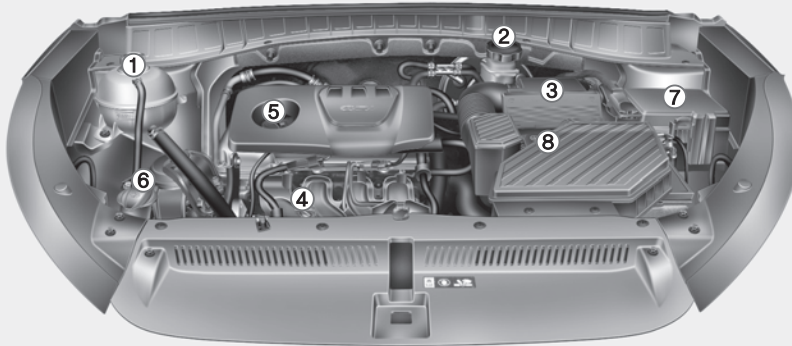

### ■ Gasoline 1.6 T-GDI

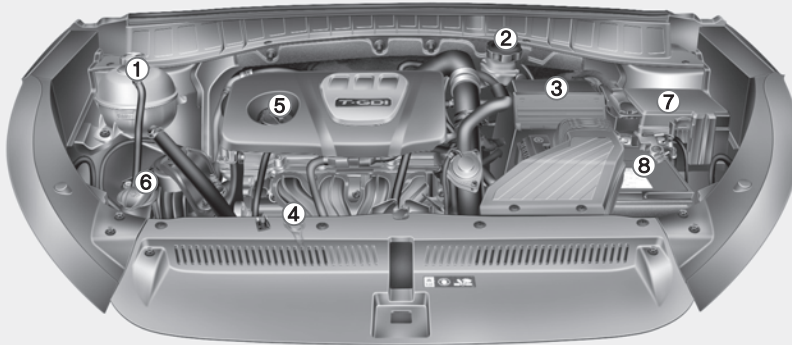

The actual engine room in the vehicle may differ from the illustration.

1. Engine coolant reservoir/.....7-33  
Radiator cap .....7-35
2. Brake/clutch fluid reservoir .....7-37
3. Air cleaner .....7-40
4. Engine oil dipstick.....7-29
5. Engine oil filler cap .....7-30
6. Windshield washer fluid reservoir.....7-38
7. Fuse box .....7-62
8. Battery .....7-46

■ Gasoline 2.0 MPI

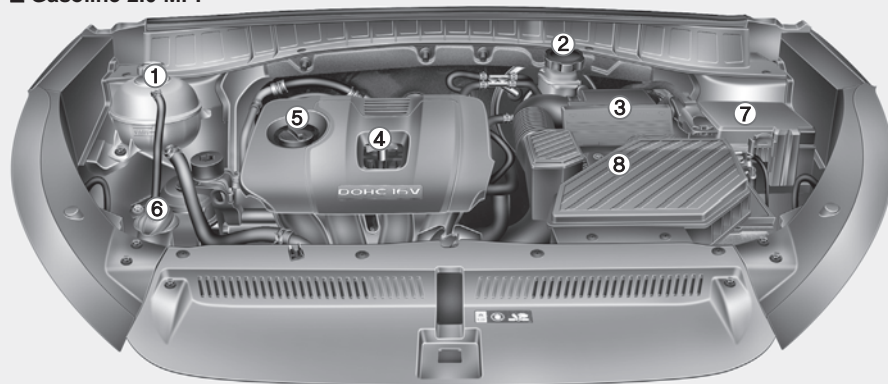

- 1. Engine coolant reservoir/.....7-33  
Radiator cap .....7-35
- 2. Brake/clutch fluid reservoir .....7-37
- 3. Air cleaner .....7-40
- 4. Engine oil dipstick.....7-29
- 5. Engine oil filler cap .....7-30
- 6. Windshield washer fluid reservoir.....7-38
- 7. Fuse box .....7-62
- 8. Battery .....7-46

■ Gasoline 2.4 GDI

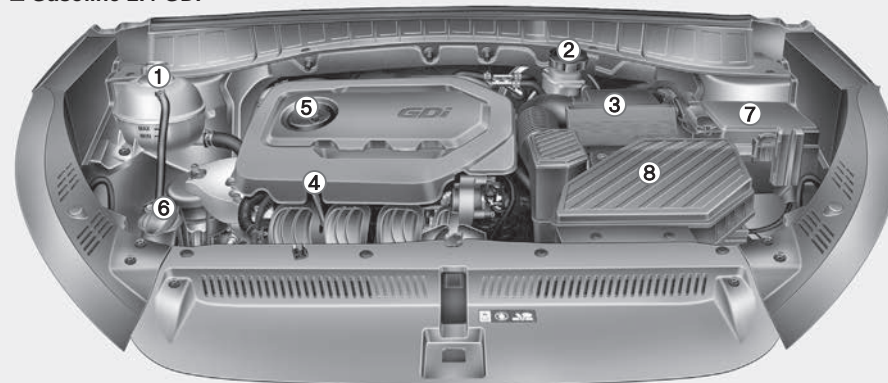

The actual engine room in the vehicle may differ from the illustration.

OTLE075003/OTLE075104

### ■ Smartstream D1.6 / Smartstream D1.6 48V MHEV

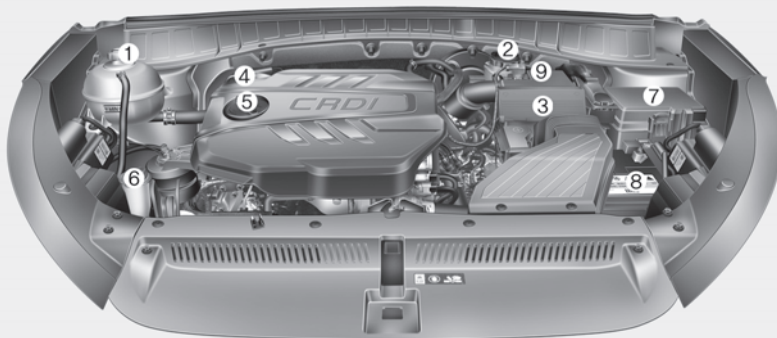

- |   |      |
|---|------|
| 1. Engine coolant reservoir/.....         | 7-33 |
| Radiator cap .....                        | 7-35 |
| 2. Brake/clutch fluid reservoir .....     | 7-37 |
| 3. Air cleaner .....                      | 7-40 |
| 4. Engine oil dipstick.....               | 7-30 |
| 5. Engine oil filler cap .....            | 7-32 |
| 6. Windshield washer fluid reservoir..... | 7-38 |
| 7. Fuse box .....                         | 7-62 |
| 8. Battery .....                          | 7-46 |
| 9. Fuel filter.....                       | 7-39 |

### ■ Diesel 2.0 TCI / Diesel 2.0 48V MHEV

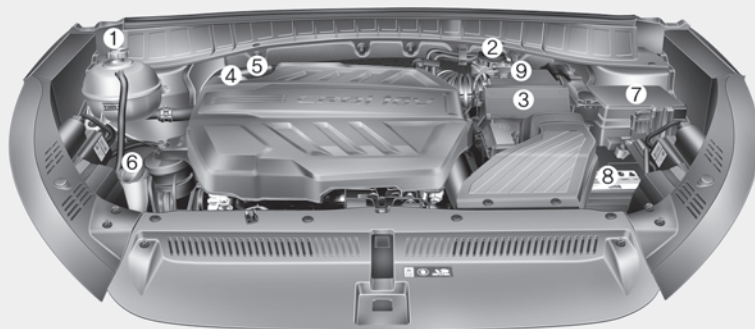

The actual engine room in the vehicle may differ from the illustration.

OTLE078002/OTLE078001

# Safety system of your vehicle

This chapter provides you with important information about how to protect yourself and your passengers. It explains how to properly use your seats and seat belts, and how your air bags work. Additionally, this chapter explains how to properly restrain infants and children in your vehicle.

<b>Important safety precautions</b> .....	2-2	<b>Child Restraint System (CRS)</b> .....	2-38
Always wear your seat belt.....	2-2	Our Recommendation: Children always in the rear ...	2-38
Restrain all children.....	2-2	Selecting a Child Restraint System (CRS) .....	2-39
Air bag hazards.....	2-2	Installing a Child Restraint System (CRS).....	2-41
Driver distraction.....	2-2	<b>Air bag</b>	
Control your speed .....	2-3	- supplemental restraint system.....	2-50
Keep your vehicle in safe condition.....	2-3	Where are the air bags? .....	2-52
<b>Seats</b> .....	2-4	How does the air bags system operate? .....	2-57
Safety precautions.....	2-5	What to expect after an air bag inflates.....	2-61
Front seats.....	2-6	Do not install a Child Restraint System on the front	
Rear seats.....	2-13	passenger seat.....	2-62
Headrest .....	2-16	Why didn't my air bag go off in a collision? .....	2-63
Seat warmers and air ventilation seats.....	2-20	SRS care .....	2-68
<b>Seat belts</b> .....	2-24	Additional safety precautions .....	2-69
Seat belt safety precautions.....	2-24	Air bag warning labels .....	2-69
Seat belt warning light .....	2-25	<b>Active hood lift system</b> .....	2-70
Seat belt restraint system .....	2-28	Possible activation situations .....	2-70
Additional seat belt safety precautions .....	2-34	Non-activation situations.....	2-71
Care of seat belts .....	2-37	System malfunction.....	2-72

### IMPORTANT SAFETY PRECAUTIONS

You will find many safety precautions and recommendations throughout this section, and throughout this manual. The safety precautions in this section are among the most important.

#### Always wear your seat belt

A seat belt is your best protection in all types of accidents. Air bags are designed to supplement seat belts, not replace them. So even though your vehicle is equipped with air bags, ALWAYS make sure you and your passengers wear your seat belts, and wear them properly.

#### Restrain all children

All children under age 13 should ride in your vehicle properly restrained in a rear seat, not the front seat. Infants and small children should be restrained in an appropriate Child Restraint System. Larger children should use a booster seat with the lap/shoulder belt until they can use the seat belt properly without a booster seat.

#### Air bag hazards

While air bags can save lives, they can also cause serious or fatal injuries to occupants who sit too close to them, or who are not properly restrained. Infants, young children, and short adults are at the greatest risk of being injured by an inflating air bag. Follow all instructions and warnings in this manual.

#### Driver distraction

Driver distraction presents a serious and potentially deadly danger, especially for inexperienced drivers. Safety should be the first concern when behind the wheel and drivers need to be aware of the wide array of potential distractions, such as drowsiness, reaching for objects, eating, personal grooming, other passengers, and using cellular phones.

Drivers can become distracted when they take their eyes and attention off the road or their hands off the wheel to focus on activities other than driving. To reduce your risk of distraction and an accident:

- ALWAYS set up your mobile devices (i.e., MP3 players, phones, navigation units, etc.) when your vehicle is parked or safely stopped.
- ONLY use your mobile device when allowed by laws and conditions permit safe use. NEVER text or email while driving. Most countries have laws prohibiting drivers from texting. Some countries and cities also prohibit drivers from using handheld phones.

- 
- NEVER let the use of a mobile device distract you from driving. You have a responsibility to your passengers and others on the road to always drive safely, with your hands on the wheel as well as your eyes and attention on the road.

### Control your speed

Excessive speed is a major factor in crash injuries and deaths. Generally, the higher the speed, the greater the risk, but serious injuries can also occur at lower speeds. Never drive faster than is safe for current conditions, regardless of the maximum speed posted.

### Keep your vehicle in safe condition

Having a tire blowout or a mechanical failure can be extremely hazardous. To reduce the possibility of such problems, check your tire pressures and condition frequently, and perform all regularly scheduled maintenance.

## SEATS

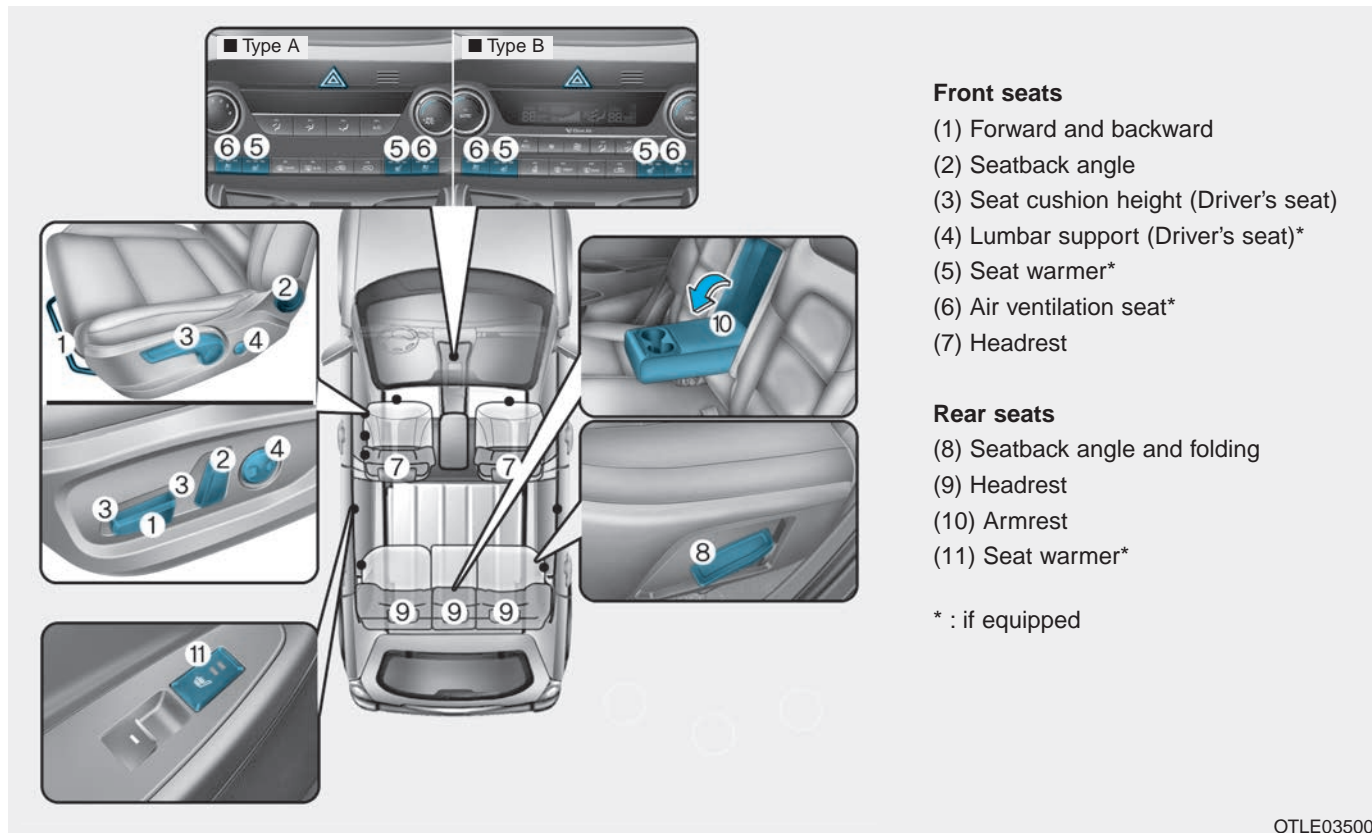

OTLE035001

## Safety precautions

Adjusting the seats so that you are sitting in a safe, comfortable position plays an important role in driver and passenger safety together with the seat belts and air bags in an accident.

### WARNING

**Do not use a cushion that reduces friction between the seat and the passenger. The passenger's hips may slide under the lap portion of the seat belt during an accident or a sudden stop.**

**Serious or fatal internal injuries could result because the seat belt cannot operate properly.**

## Air bags

You can take steps to reduce the risk of being injured by an inflating air bag. Sitting too close to an air bag greatly increases the risk of injury in the event the air bag inflates. Move your seat as far back as possible from front air bags, while still maintaining control of the vehicle.

### WARNING

**To reduce the risk of serious injury or death from an inflating air bag, take the following precautions:**

- **Adjust the driver's seat as far to the rear as possible maintaining the ability to control of the vehicle.**
- **Adjust the front passenger seat as far to the rear as possible.**

**(Continued)**

**(Continued)**

- **Hold the steering wheel by the rim with hands at the 9 o'clock and 3 o'clock positions to minimize the risk of injuries to your hands and arms.**
- **NEVER place anything or anyone between the air bag.**
- **Do not allow the front passenger to place feet or legs on the dashboard to minimize the risk of leg injuries.**



### Seat belts

Always fasten your seat belt before starting any trip.

At all times, passengers should sit upright and be properly restrained. Infants and small children must be restrained in appropriate Child Restraint Systems. Children who have outgrown a booster seat and adults must be restrained using the seat belts.

#### WARNING

Take the following precautions when adjusting your seat belt:

- NEVER use one seat belt for more than one occupant.
- Always position the seatback upright with the lap portion of the seat belt snug and low across the hips.
- NEVER allow children or small infants to ride in a passenger's lap.

(Continued)

(Continued)

- Do not route the seat belt across your neck, across sharp edges, or reroute the shoulder strap away from your body.
- Do not allow the seat belt to become caught or jammed.

### Front seats

The front seat can be adjusted by using the control switches located on the outside of the seat cushion. Before driving, adjust the seat to the proper position so that you can easily control the steering wheel, foot pedals and controls on the instrument panel.

#### WARNING

Take the following precautions when adjusting your seat:

- NEVER attempt to adjust the seat while the vehicle is moving. The seat could respond with unexpected movement and may cause loss of vehicle control resulting in an accident.
- Do not place anything under the front seats. Loose objects in the driver's foot area could interfere with the operation of the foot pedals, causing an accident.

(Continued)

(Continued)

- Do not allow anything to interfere with the normal position and proper locking of the seat-back.
- Do not place a cigarette lighter on the floor or seat. When you operate the seat, gas may exit out of the lighter causing a fire.
- Use extreme caution when picking small objects trapped under the seats or between the seat and the center console. Your hands might be cut or injured by the sharp edges of the seat mechanism.
- If there are occupants in the rear seats, be careful while adjusting the front seat position.

**⚠ CAUTION**

To prevent injury:

- Do not adjust your seat while wearing your seat belt. Moving the seat cushion forward may cause strong pressure on your abdomen.
- Do not allow your hands or fingers to get caught in the seat mechanisms while the seat is moving.

**Manual adjustment**

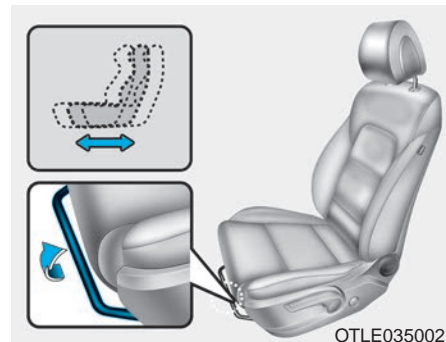

**Forward and rearward adjustment**

To move the seat forward or rearward:

1. Pull up the seat slide adjustment lever and hold it.
2. Slide the seat to the position you desire.
3. Release the lever and make sure the seat is locked in place. Move forward and rearward without using the lever. If the seat moves, it is not locked properly.

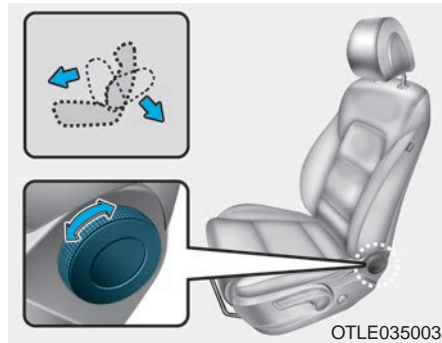

### Seatback angle

To recline the seatback:

1. Roll the seatback knob rearward.
2. Carefully lean back on the seat and adjust the seatback to the position you desire.
3. Release the knob and make sure the seatback is locked in place.

### Reclining seatback

Sitting in a reclined position when the vehicle is in motion can be dangerous. Even when buckled up, the protections of your restraint system (seat belts and/or air bags) is greatly reduced by reclining your seatback.

### **WARNING**

**NEVER ride with a reclined seatback when the vehicle is moving.**

**Riding with a reclined seatback increases your chance of serious or fatal injuries in the event of a collision or sudden stop.**

**Drivers and passengers should ALWAYS sit well back in their seats, properly belted, and with the seatbacks upright.**

Seat belts must be snug against your hips and chest to work properly. When the seatback is reclined, the shoulder belt cannot do its job because it will not be snug against your chest. Instead, it will be in front of you. During an accident, you could be thrown into the seat belt, causing neck or other injuries.

The more the seatback is reclined, the greater chance the passenger's hips will slide under the lap belt or the passenger's neck will strike the shoulder belt.

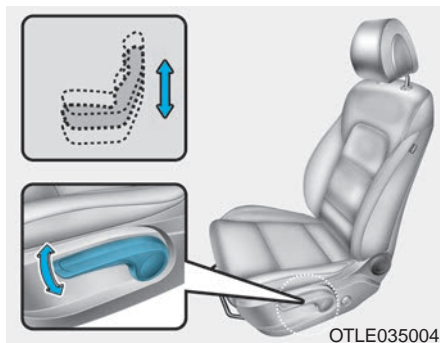

### Seat cushion height (if equipped)

To change the height of the seat cushion:

- Push down the lever several times, to lower the seat cushion.
- Pull up the lever several times, to raise the seat cushion.

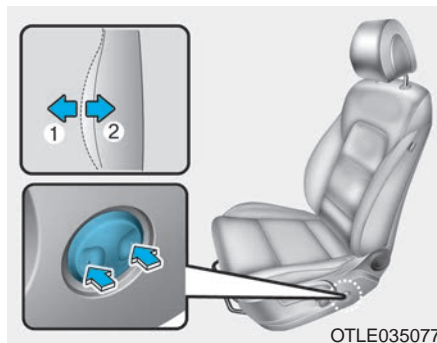

### Lumbar support (for driver's seat, if equipped)

The lumbar support can be adjusted by pressing the lumbar support switch on the side of the seat.

1. Press the front portion of the switch to increase support, or the rear portion of the switch, to decrease support.
2. Release the switch once it reaches the desired position.

### Power adjustment

The front seat can be adjusted by using the control switches located on the outside of the seat cushion. Before driving, adjust the seat to the proper position so that you can easily control the steering wheel, foot pedals and controls on the instrument panel.

#### **⚠ WARNING**

**NEVER allow children in the vehicle unattended. The power seats are operable when the engine is turned off.**

### NOTICE

To prevent damage to the seats:

- Always stop adjusting the seats when the seat has been adjusted as far forward or rearward as possible.
- Do not adjust the seats longer than necessary when the engine is turned off. This may result in unnecessary battery drain.
- Do not operate two or more seats at the same time. This may result in an electrical malfunction.

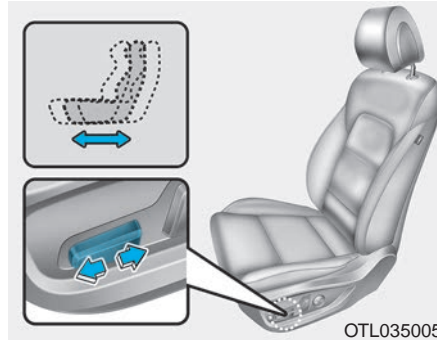

#### Forward and rearward adjustment

To move the seat forward or rearward:

1. Push the control switch forward or rearward.
2. Release the switch once the seat reaches the desired position.

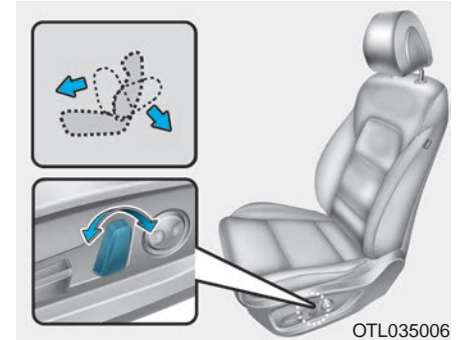

#### Seatback angle

To recline the seatback:

1. Push the control switch forward or rearward.
2. Release the switch once the seatback reaches the desired position.

## Reclining seatback

Sitting in a reclined position when the vehicle is in motion can be dangerous. Even when buckled up, the protections of your restraint system (seat belts and air bags) is greatly reduced by reclining your seatback.

### **⚠ WARNING**

**NEVER ride with a reclined seatback when the vehicle is moving. Riding with a reclined seatback increases your chance of serious or fatal injuries in the event of a collision or sudden stop.**

**Driver and passengers should ALWAYS sit well back in their seats, properly belted, and with the seatbacks upright.**

Seat belts must be snug against your hips and chest to work properly. When the seatback is reclined, the shoulder belt cannot do its job because it will not be snug against your chest. Instead, it will be in front of you. During an accident, you could be thrown into the seat belt, causing neck or other injuries.

The more the seatback is reclined, the greater chance the passenger's hips will slide under the lap belt or the passenger's neck will strike the shoulder belt.

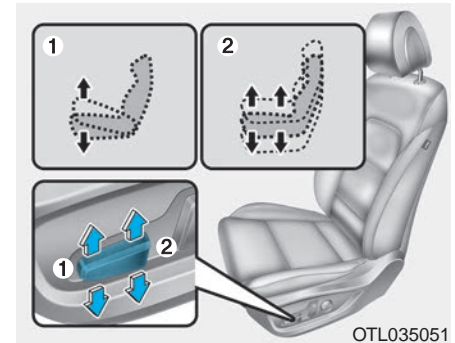

### **Seat cushion angle (1)**

To change the angle of the front part of the seat cushion:

Push the front portion of the control switch up to raise or down to lower the front part of the seat cushion.

Release the switch once the seat reaches the desired position.

### **Seat cushion height (2)**

To change the height of the seat cushion:

Push the rear portion of the control switch up to raise or down to lower the height of the seat cushion.

Release the switch once the seat reaches the desired position.

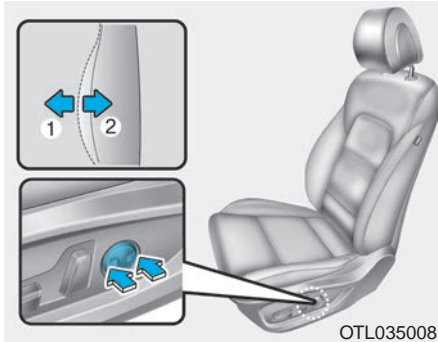

**Lumbar support (for driver's seat, if equipped)**

- The lumbar support can be adjusted by pressing the lumbar support switch.
- Press the front portion of the switch (1) to increase support or the rear portion of the switch (2) to decrease support.

**Seatback pocket**

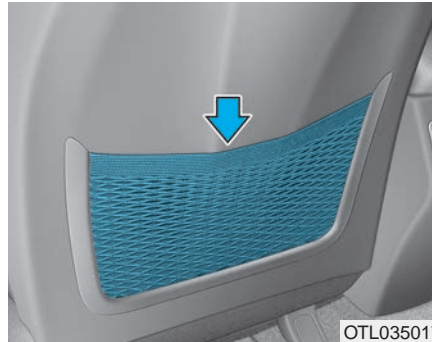

The seatback pocket is provided on the back of the front seatbacks.

**⚠ CAUTION**

Do not put heavy or sharp objects in the seatback pockets. In an accident they could come loose from the pocket and injure occupants.

## Rear seats

### *Folding the rear seat*

The rear seatbacks can be folded to facilitate carrying long items or to increase the luggage capacity of the vehicle.

#### **⚠ WARNING**

- **Never allow passengers to sit on top of the folded down seatback while the vehicle is moving. This is not a proper seating position and no seat belts are available for use. This could result in serious injury or death in case of an accident or sudden stop.**
- **Objects carried on the folded down seatback should not extend higher than the top of the front seatbacks. This could allow cargo to slide forward and cause injury or damage during sudden stops.**

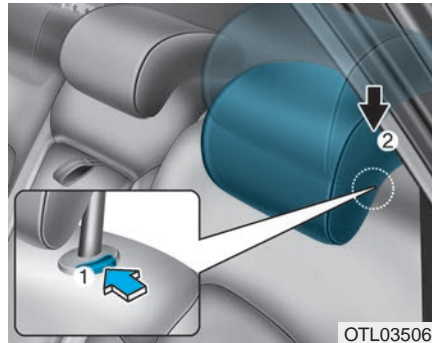

To fold down the rear seatback:

1. Set the front seatback to the upright position and if necessary, slide the front seat forward.
2. Lower the rear head restraints to the lowest position.

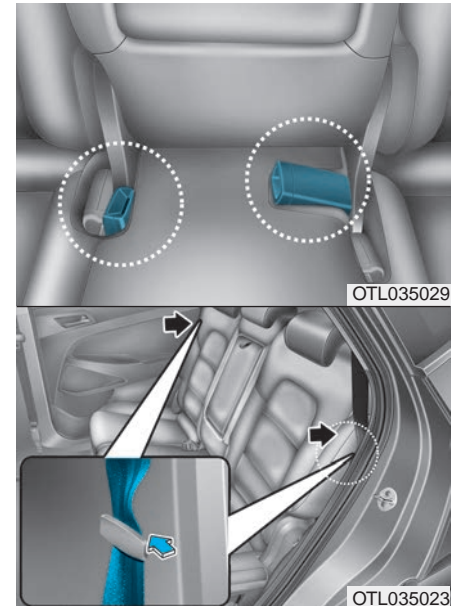

3. Insert the rear seat belt buckle in the pocket between the rear seatback and cushion, and insert the rear seat belt webbing in the guide to prevent the seat belt from being damaged.



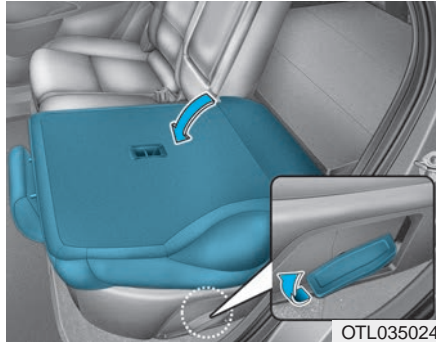

4. Lift up the front portion of the seatback folding lever, then fold the seatback toward the front of the vehicle. When you return the seatback to its upright position, always be sure it has locked into position by pushing on the top of the seatback.

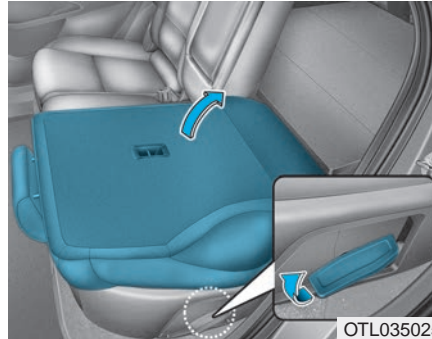

5. To use the rear seat, lift and push the seatback rearward by lifting up the front portion of the folding lever. Push the seatback firmly until it clicks into place. Make sure the seatback is locked in place.

**⚠ WARNING**

When returning the rear seatback from a folded to an upright position, hold the seatback and return it slowly. Ensure that the seatback is completely locked into its upright position by pushing on the top of the seatback. In an accident or sudden stop, the unlocked seatback could allow cargo to move forward with great force and enter the passenger compartment, which could result in serious injury or death.

**⚠ WARNING**

Do not place objects in the rear seats, since they cannot be properly secured and may hit vehicle occupants in a collision causing serious injury or death.

## **⚠ WARNING**

Make sure the engine is off, the shift lever is in P (Park), and the parking brake is securely applied whenever loading or unloading cargo. Failure to take these steps may allow the vehicle to move if the shift lever is inadvertently moved to another position.

### **Armrest**

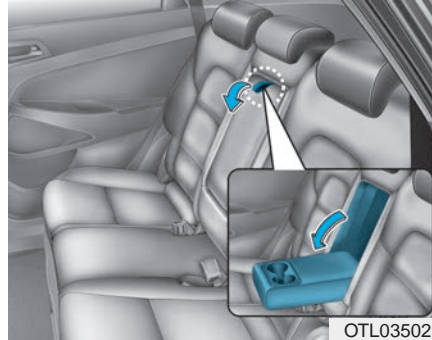

The armrest is located in the center of the rear seat. Pull the armrest down from the seatback to use it.

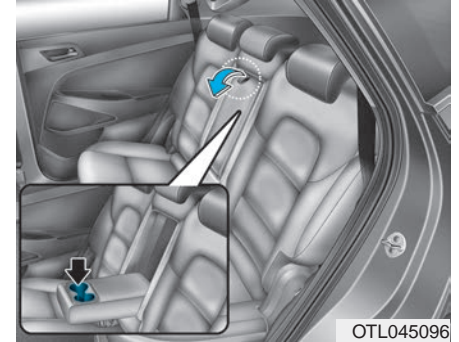

### **Cup holder**

To use the center cup holder, pull down the armrest.

### Headrest

The vehicle's front and rear seats have adjustable headrests. The headrests provide comfort for passengers, but more importantly they are designed to help protect passengers from whiplash and other neck and spinal injuries during an accident, especially in a rear impact collision.

#### WARNING

To reduce the risk of serious injury or death in an accident, take the following precautions when adjusting your headrests:

- Always properly adjust the headrests for all passengers **BEFORE** starting the vehicle.
- **NEVER** let anyone ride in a seat with the headrest removed.

(Continued)

(Continued)

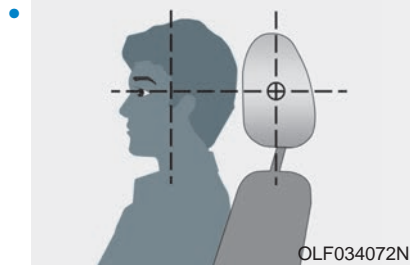

- Adjust the headrests so the middle of the headrests is at the same height as the height of the top of the eyes.
- **NEVER** adjust the headrest position of the driver's seat when the vehicle is in motion.
- Adjust the headrest as close to the passenger's head as possible. Do not use a seat cushion that holds the body away from the seatback.
- Make sure the headrest locks into position after adjusting it.

#### NOTICE

To prevent damage, **NEVER** hit or pull on the headrests.

#### CAUTION

When there is no occupant in the rear seats, adjust the height of the headrest to the lowest position. The rear seat headrest can reduce the visibility of the rear area.

## Front seat headrests

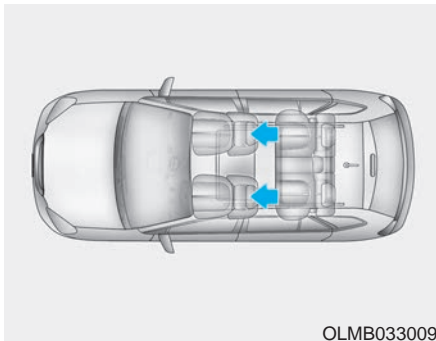

The driver's and front passenger's seats are equipped with adjustable headrests for the passengers safety and comfort.

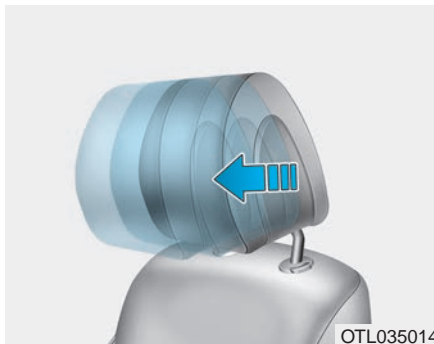

### Forward and rearward adjustment

The headrest may be adjusted forward to 3 different positions by pulling the headrest forward to the desired detent. To adjust the headrest to its furthest rearwards position, pull it fully forward to the farthest position and release it.

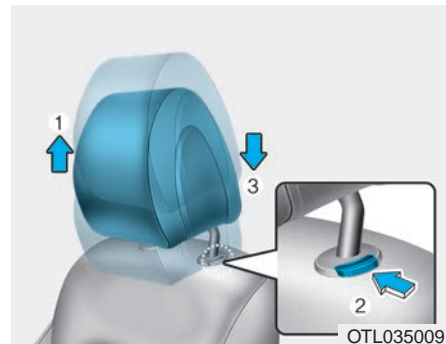

### Adjusting the height up and down

To raise the headrest:

1. Pull it up to the desired position (1).

To lower the headrest:

1. Push and hold the release button (2) on the headrest support.
2. Lower the headrest to the desired position (3).

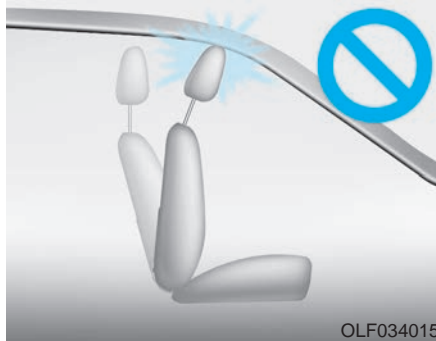

### NOTICE

If you recline the seatback towards the front with the headrest and seat cushion raised, the headrest may come in contact with the sunvisor or other parts of the vehicle.

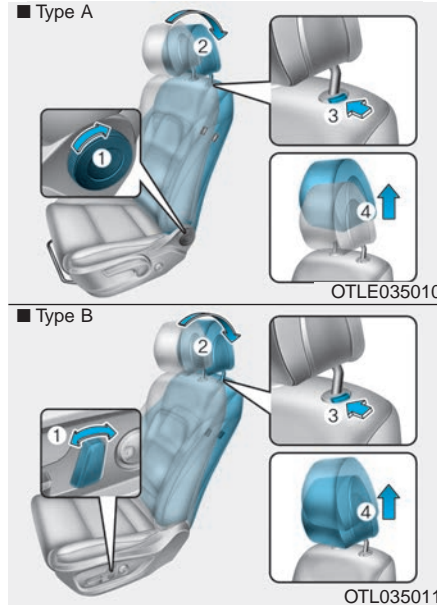

### Removal/Reinstall

To remove the headrest:

1. Recline the seatback (2) with using the seatback angle knob or switch (1).
2. Raise headrest as far as it can go.
3. Press the headrest release button (3) while pulling the headrest up (4).

3. Press the headrest release button (3) while pulling the headrest up (4).

### ⚠ WARNING

**NEVER** allow anyone to travel in a seat with the headrest removed.

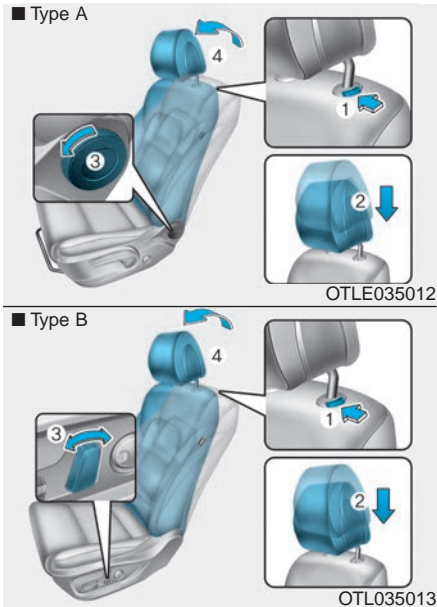

4. Recline the seatback (4) with the seatback angle knob or switch (3).

### ⚠ WARNING

**Always make sure the headrest locks into position after reinstalling and adjusting it properly.**

### Rear seat headrests

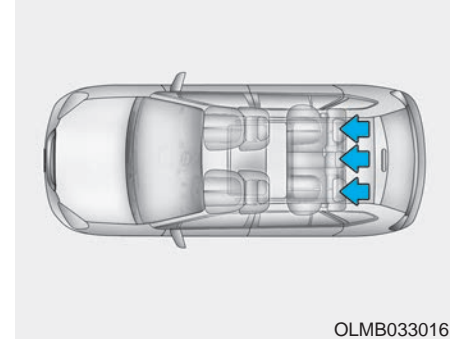

The rear seats are equipped with headrests in all the seating positions for the passenger's safety and comfort.

To reinstall the headrest :

1. Recline the seatback.
2. Put the headrest poles (2) into the holes while pressing the release button (1).
3. Adjust the headrest to the appropriate height.

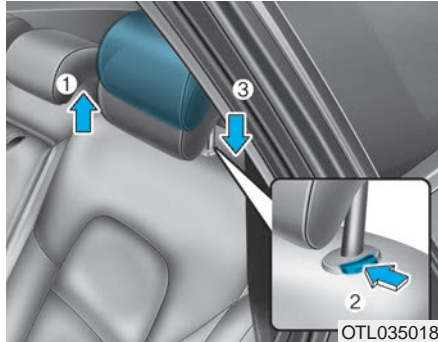

### Adjusting the height up and down

To raise the headrest:

1. Pull it up to the desired position (1).

To lower the headrest:

1. Push and hold the release button (2) on the headrest support.
2. Lower the headrest to the desired position (3).

## Seat warmers and air ventilation seats

### Front seat warmers (if equipped)

Seat warmers are provided to warm the seats during cold weather.

#### **⚠ WARNING**

The seat warmers can cause a **SERIOUS BURN**, even at low temperatures and especially if used for long periods of time.

Passengers must be able to feel if the seat is becoming too warm so they can turn it off, if needed.

People who cannot detect temperature change or pain to the skin should use extreme caution, especially the following types of passengers:

- Infants, children, elderly or disabled persons, or hospital outpatients.
- People with sensitive skin or who burn easily.
- Fatigued individuals.
- Intoxicated individuals.

(Continued)

(Continued)

- People taking medication that can cause drowsiness or sleepiness.

#### **⚠ WARNING**

**NEVER** place anything on the seat that insulates against heat when the seat warmer is in operation, such as a blanket or seat cushion. This may cause the seat warmer to overheat, causing a burn or damage to the seat.

#### **NOTICE**

To prevent damage to the seat warmers and seats:

- Never use a solvent such as paint thinner, benzene, alcohol or gasoline to clean the seats.
- Do not place heavy or sharp objects on seats equipped with seat warmers.
- Do not change the seat cover. It may damage the seat warmer.

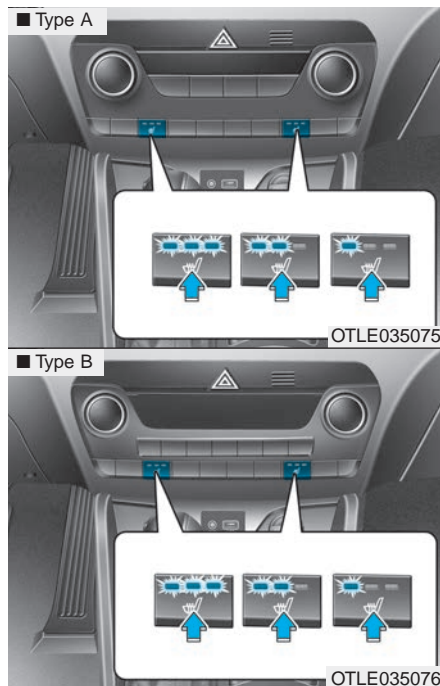

While the engine is running, push either of the switches to warm the driver's seat or front passenger's seat.

During mild weather or under conditions where the operation of the seat warmer is not needed, keep the switches in the OFF position.

- Manual temperature control

Each time you push the switch, the temperature setting of the seat is changed as follows :

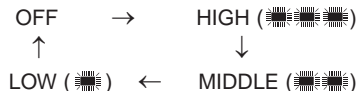

- Automatic temperature control

The seat warmer starts to automatically control the seat temperature in order to prevent low-temperature burns after being manually turned ON.

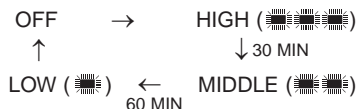

If HIGH temperature is manually selected again, the temperature will be controlled automatically.

- When pressing the switch for more than 1.5 seconds with the seat warmer operating, the seat warmer will turn OFF.
- The seat warmer defaults to the OFF position whenever the ignition switch is placed to the ON position.

### **i** Information

**With the seat warmer switch in the ON position, the heating system in the seat turns off or on automatically depending on the seat temperature.**



## Front air ventilation seat (if equipped)

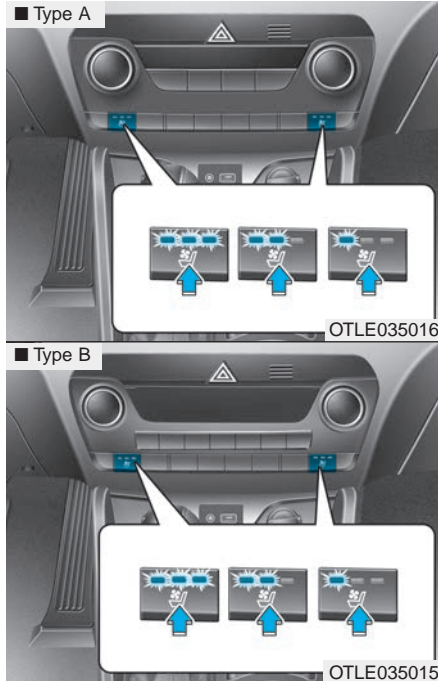

The air ventilation seats are provided to cool the front seats by blowing air through small vent holes on the surface of the seat cushions and seat-backs.

When the operation of the air ventilation seat is not needed, keep the switches in the OFF position.

While the engine is running, push the switch to cool the driver's seat or the front passenger's seat (if equipped).

- Each time you push the switch, the airflow changes as follows:

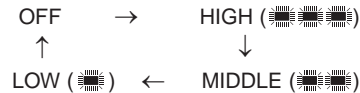

- When pressing the switch for more than 1.5 seconds with the air ventilation seat operating, the operation will turn OFF.
- The air ventilation seats defaults to the OFF position whenever the ignition switch is placed to the ON position.

### NOTICE

To prevent damage to the air ventilation seat:

- Use the air ventilation seat **ONLY** when the climate control system is on. Using the air ventilation seat for prolonged periods of time with the climate control system off could cause the air ventilation seat to malfunction.
- Never use a solvent such as paint thinner, benzene, alcohol or gasoline to clean the seats.
- Avoid spilling liquids on the surface of the front seats and seat-backs; this may cause the air vent holes to become blocked and not work properly.
- Do not place materials such as plastic bags or newspapers under the seats. They may block the air intake causing the air vents to not work properly.

(Continued)

(Continued)

- Do not change the seat covers. It may damage the air ventilation seat.
- If the air vents do not operate, restart the vehicle. If there is no change, we recommend that you have your vehicle inspected by an authorized HYUNDAI dealer.

### Rear seat warmers (if equipped)

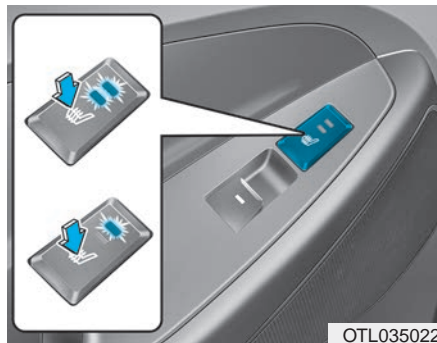

While the engine is running, push either of the switches to warm the rear seat.

During mild weather or under conditions where the operation of the seat warmer is not needed, keep the switches in the OFF position.

- Manual temperature control

Each time you push the switch, the temperature setting of the seat is changed as follows :



- Automatic temperature control  
The seat warmer starts to automatically control the seat temperature in order to prevent low-temperature burns after being manually turned ON.



If HIGH temperature is manually selected again, the temperature will be controlled automatically.

- The seat warmer defaults to the OFF position whenever the ignition switch is placed to the ON position.

### **i** Information

**With the seat warmer switch in the ON position, the heating system in the seat turns off or on automatically depending on the seat temperature.**

## SEAT BELTS

This section describes how to use the seat belts properly. It also describes some of the things not to do when using seat belts.

### Seat belt safety precautions

Always fasten your seat belt and make sure all passengers have fastened their seat belts before starting any trip. Air bags (if equipped) are designed to supplement the seat belt as an additional safety device, but they are not a substitute. Most countries require all occupants of a vehicle to wear seat belts.

#### WARNING

**Seat belts must be used by ALL passengers whenever the vehicle is moving. Take the following precautions when adjusting and wearing seat belts:**

- **Children under the age of 13 should be properly restrained in the rear seats.**
- **Never allow children to ride in the front passenger seat, unless the air bag is deactivated. If a child is seated in the front passenger seat, move the seat as far back as possible and properly restrain them in the seat.**
- **NEVER allow an infant or child to be carried on an occupant's lap.**
- **NEVER ride with the seatback reclined when the vehicle is moving.**
- **Do not allow children to share a seat or seat belt.**

(Continued)

(Continued)

- **Do not wear the shoulder belt under your arm or behind your back.**
- **Never wear a seat belt over fragile objects. If there is a sudden stop or impact, the seat belt can damage it.**
- **Do not use the seat belt if it is twisted. A twisted seat belt will not protect you properly in an accident.**
- **Do not use a seat belt if the webbing or hardware is damaged.**
- **Do not latch the seat belt into the buckles of other seats.**
- **NEVER unfasten the seat belt while driving. This may cause loss of vehicle control resulting in an accident.**
- **Make sure there is nothing in the buckle interfering with the seat belt latch mechanism. This may prevent the seat belt from fastening securely.**

(Continued)

(Continued)

- No modifications or additions should be made by the user which will either prevent the seat belt adjusting devices from operating to remove slack, or prevent the seat belt assembly from being adjusted to remove slack.

## ⚠ WARNING

Damaged seat belts and seat belt assemblies will not operate properly. Always replace:

- Frayed, contaminated, or damaged webbing.
- Damaged hardware.
- The entire seat belt assembly after it has been worn in an accident, even if damage to webbing or assembly is not apparent.

## Seat belt warning light

### Seat belt warning

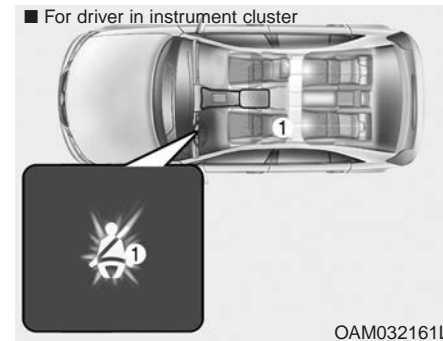

### Driver's seat belt warning

As a reminder to the driver, the seat belt warning light will illuminate for approximately 6 seconds each time you turn the ignition switch ON regardless of belt fastening.

If the driver's seat belt is unfastened after the ignition switch is ON, the seat belt warning light illuminates until the belt is fastened.

If you continue not to fasten the seat belt and you drive over 9 km/h, the illuminated warning light will start to blink until you drive under 6 km/h. (if equipped)

If you continue not to fasten the seat belt and you drive over 20 km/h the seat belt warning chime will sound for approximately 100 seconds and the corresponding warning light will blink. (if equipped)

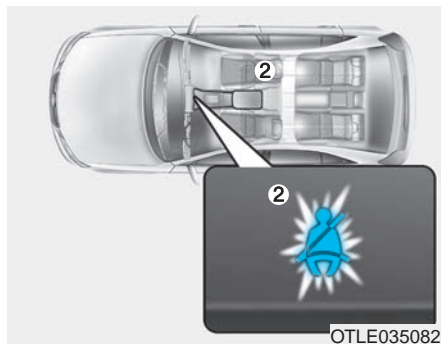

### Front passenger's seat belt warning

As a reminder to the front passenger, the front passenger's seat belt warning lights will illuminate for approximately 6 seconds each time you turn the ignition switch ON regardless of belt fastening.

If the front passenger's seat belt is not fastened when the ignition switch is turned ON or if it is disconnected after the ignition switch is turned ON, the corresponding seat belt warning light will illuminate until the belt is fastened.

If you continue not to fasten the seat belt and you drive over 9 km/h, the illuminated warning light will start to blink until you drive under 6 km/h.

If you continue not to fasten the seat belt and you drive over 20 km/h the seat belt warning chime will sound for approximately 100 seconds and the corresponding warning light will blink.

### WARNING

**Riding in an improper position adversely affects the front passenger's seat belt warning system. It is important for the driver to instruct the passenger to properly be seated as instructed in this manual.**

## **i** Information

- You can find the front passenger's seat belt warning light on the center fascia panel.
- Although the front passenger seat is not occupied, the seat belt warning light will blink or illuminate for 6 seconds.
- The front passenger's seat belt warning may operate when luggage is placed on the front passenger seat.

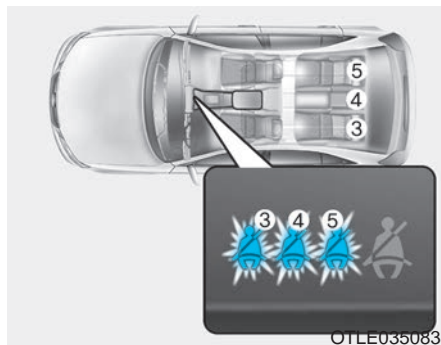

### Rear passenger's seat belt warning

If the ignition switch is turned ON (engine is not running) when the rear passenger's lap/shoulder belt is not fastened, the corresponding seat belt warning light will illuminate until the belt is fastened.

And then, the rear corresponding seat belt warning light will illuminate for approximately 35 seconds, if any of following occurs;

- You start the engine when the rear belt is not fastened.
- You drive over 9 km/h when the rear belt is not fastened.
- The rear belt is disconnected when driving under 20 km/h.

If the rear seat belt is fastened, the warning light will turn off immediately.

If the rear seat belt is disconnected when you drive over the 20 km/h, the corresponding seat belt warning light will blink and warning chime will sound for 35 seconds.

But, if the rear passenger's lap/shoulder belt is/are connected and disconnected twice within 9 seconds after the belt is fastened, the corresponding seat belt warning light will not operate.

## Seat belt restraint system

### Lap/shoulder belt

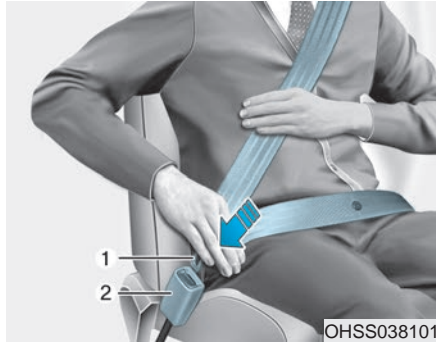

#### To fasten your seat belt:

Pull it out of the retractor and insert the metal tab (1) into the buckle (2). There will be an audible "click" when the tab locks into the buckle.

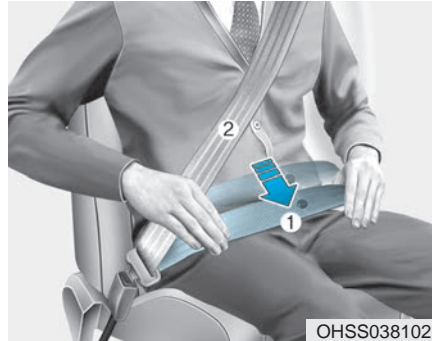

You should place the lap belt (1) portion across your hips and the shoulder belt (2) portion across your chest.

The seat belt automatically adjusts to the proper length after the lap belt portion is adjusted manually so that it fits snugly around your hips. If you lean forward in a slow, easy motion, the belt will extend and move with you. If there is a sudden stop or impact, the belt will lock into position. It will also lock if you try to lean forward too quickly.

#### NOTICE

If you are not able to smoothly pull enough of the seat belt out from the retractor, firmly pull the seat belt out and release it. After release, you will be able to pull the belt out smoothly.



#### ⚠ WARNING

Improperly positioned seat belts may increase the risk of serious injury in an accident. Take the following precautions when adjusting the seat belt:

(Continued)

**(Continued)**

- Position the lap portion of the seat belt as low as possible across your hips, not on your waist, so that it fits snugly. This allows your strong pelvic bones to absorb the force of the crash, reducing the chance of internal injuries.
- Position one arm under the shoulder belt and the other over the belt, as shown in the illustration.
- Always position the shoulder belt anchor into locked position at the appropriate height.
- Never position the shoulder belt across your neck or face.

**Height adjustment**

You can adjust the height of the shoulder belt anchor to one of the four different positions for maximum comfort and safety.

The shoulder portion should be adjusted so it lies across your chest and midway over your shoulder nearest the door, not over your neck.

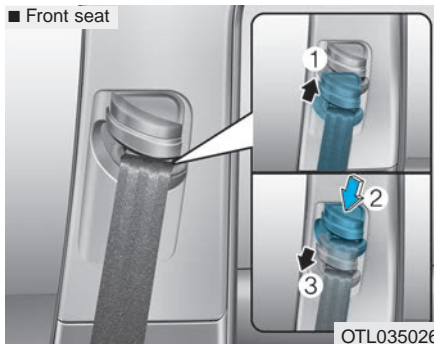

To adjust the height of the seat belt anchor, lower or raise the height adjuster into an appropriate position.

To raise the height adjuster, pull it up (1). To lower it, push it down (3) while pressing the height adjuster button (2). Release the button to lock the anchor into position. Try sliding the height adjuster to make sure that it has locked into position.



**To release your seat belt:**

Press the release button (1) in the locking buckle.

When it is released, the belt should automatically draw back into the retractor. If this does not happen, check the belt to be sure it is not twisted, then try again.



**Rear center seatbelt  
(3-point rear center seat belt)**

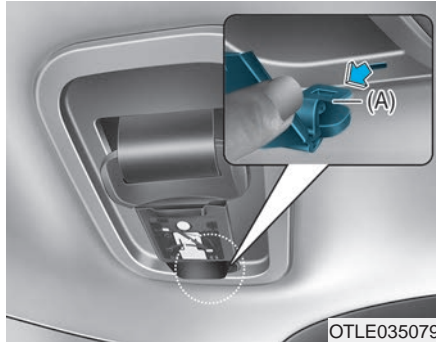

**To fasten your seatbelt**

1. Extract the tongue plate (A) from the hole on the belt assembly cover.

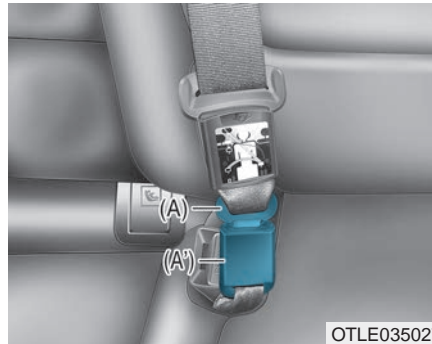

2. Insert the tongue plate (A) into the buckle (A') until an audible "click" is heard, indicating the latch is locked. Make sure the belt is not twisted.

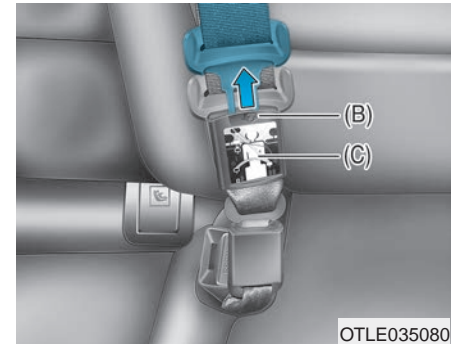

3. Pull out the tongue plate (B) from the pocket (C).

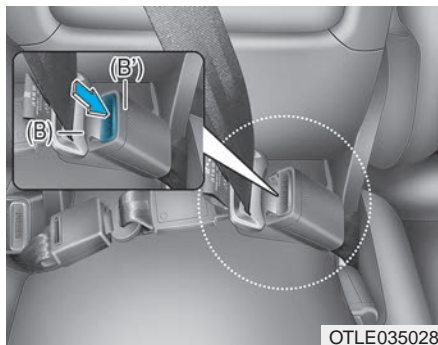

OTLE035028

4. Pull the tongue plate (B) and insert it into the buckle (B') until an audible “click” is heard, indicating the latch is locked. Make sure the belt is not twisted.

When using the rear center seat belt, the buckle with the “CENTER” mark must be used.

### **i** Information

**If you are not able to pull out the safety belt from the retractor, firmly pull the belt out and release it. After release, you will be able to pull the belt out smoothly.**

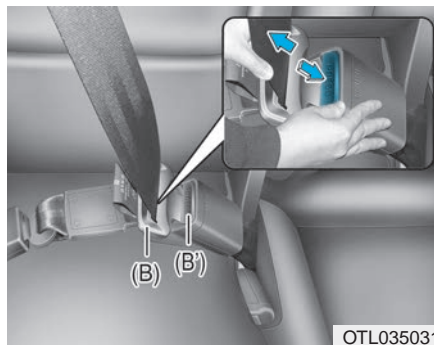

OTL035031

### To release your seatbelt

1. Press the release button on the buckle (B') and remove the tongue plate (B).

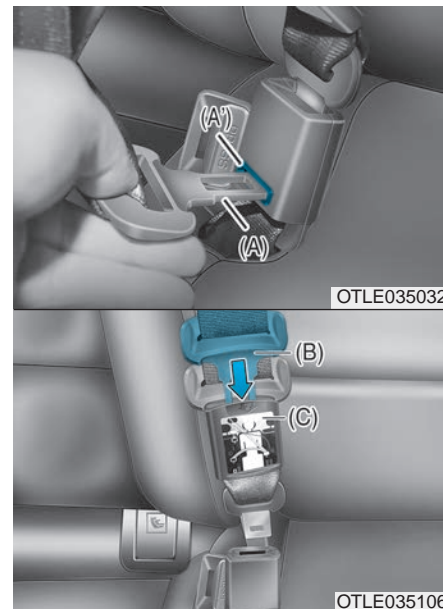

OTLE035032

OTLE035106

2. To retract the rear center seatbelt, insert the tongue plate (A) into the web release hole (A'). Pull up on the seat belt web and allow the webbing to retract automatically.
3. Insert the tongue plate (B) into the pocket (C).

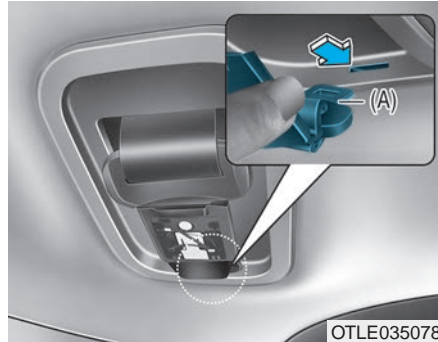

4. Insert the tongue plate (A) into the hole on the belt assembly cover.

### Pre-tensioner seat belt



Your vehicle is equipped with driver's and front passenger's Pre-tensioner Seat Belts (Retractor Pretensioner and Emergency Fastening Device (EFD)). The purpose of the pre-tensioner is to make sure the seat belts fit tightly against the occupant's body in certain frontal collisions. The pre-tensioner seat belts may be activated in crashes where the frontal collision is severe enough, together with the air bags.

When the vehicle stops suddenly, or if the occupant tries to lean forward too quickly, the seat belt retractor will lock into position. In certain frontal collisions, the pre-tensioner will activate and pull the seat belt into tighter contact against the occupant's body.

#### (1) Retractor Pretensioner

The purpose of the retractor pre-tensioner is to make sure that the shoulder belts fit in tightly against the occupant's upper body in certain frontal collisions.

#### (2) Emergency Fastening Device (EFD) (for the driver's seat, if equipped)

The purpose of the EFD is to make sure that the pelvic belts fit in tightly against the occupant's lower body in certain frontal collisions.

If the system senses excessive tension on the driver or passenger's seat belt when the pre-tensioner system activates, the load limiter inside the retractor pre-tensioner will release some of the pressure on the affected seat belt.

## **⚠ WARNING**

- Always wear your seat belt and sit properly in your seat.
- Do not use the seat belt if it is loose or twisted. A loose or twisted seat belt will not protect you properly in an accident.
- Do not place anything near the buckle. This may adversely affect the buckle and cause it to function improperly.
- Always replace your pre-tensioners after activation or an accident.
- NEVER inspect, service, repair or replace the pre-tensioners yourself. This must be done by an authorized HYUNDAI dealer.
- Do not hit the seat belt assemblies.

## **⚠ WARNING**

Do not touch the pre-tensioner seat belt assemblies for several minutes after they have been activated. When the pre-tensioner seat belt mechanism deploys during a collision, the pre-tensioner can become hot and can burn you.

## **⚠ CAUTION**

Body work on the front area of the vehicle may damage the pre-tensioner seat belt system. Therefore, we recommend the system to be serviced by an authorized HYUNDAI dealer.

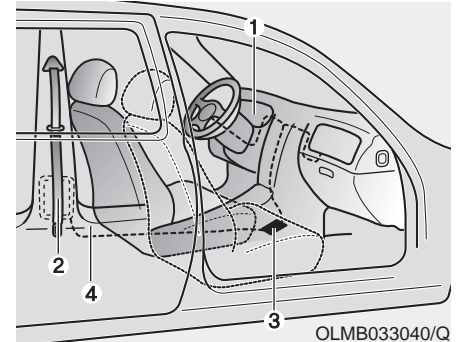

The Pre-Tensioner Seat Belt System consists mainly of the following components. Their locations are shown in the illustration above:

- (1) SRS air bag warning light
- (2) Retractor pre-tensioner
- (3) SRS control module
- (4) Emergency Fastening Device (EFD) (if equipped)

### NOTICE

The sensor that activates the SRS air bag is connected with the pre-tensioner seat belts. The SRS air bag warning light on the instrument panel will illuminate for approximately 6 seconds after the ignition switch is placed to the ON position, and then it should turn off. If the pre-tensioner is not working properly, the warning light will illuminate even if the SRS air bag is not malfunctioning. If the warning light does not illuminate, stays illuminated or illuminates when the vehicle is being driven, we recommend the pre-tensioner seat belts and/or SRS air bags be inspected by an authorized HYUNDAI dealer as soon as possible.

### Information

- Both the driver's and front passenger's pre-tensioner seat belts may be activated in certain frontal or side collisions.
- The pre-tensioners will be activated even if the seat belts are not worn at the time of the collision.
- When the pre-tensioner seat belts are activated, a loud noise may be heard and fine dust, which may appear to be smoke, may be visible in the passenger compartment. These are normal operating conditions and are not hazardous.
- Although it is non-toxic, the fine dust may cause skin irritation and should not be breathed for prolonged periods. Wash all exposed skin areas thoroughly after an accident in which the pre-tensioner seat belts were activated.

### Additional seat belt safety precautions

#### *Seat belt use during pregnancy*

The seat belt should always be used during pregnancy. The best way to protect your unborn child is to protect yourself by always wearing the seat belt.

Pregnant women should always wear a lap-shoulder seat belt. Place the shoulder belt across your chest, routed between your breasts and away from your neck. Place the lap belt below your belly so that it fits **SNUGLY** across your hips and pelvic bone, under the rounded part of the belly.

### WARNING

To reduce the risk of serious injury or death to an unborn child during an accident, pregnant women should **NEVER** place the lap portion of the seat belt above or over the area of the abdomen where the unborn child is located.

## ***Seat belt use and children***

### **Infant and small children**

Most countries have Child Restraint System laws which require children to travel in approved Child Restraint System devices, including booster seats. The age at which seat belts can be used instead of Child Restraint System differs among countries, so you should be aware of the specific requirements in your country, and where you are travelling. Infant and Child Restraint System must be properly placed and installed in a rear seat.

For more details, refer to the “Child Restraint Systems” in this chapter.

### **⚠ WARNING**

**ALWAYS properly restrain infants and small children in a Child Restraint System appropriate for the child's height and weight.**

**To reduce the risk of serious injury or death to a child and other passengers, NEVER hold a child in your lap or arms when the vehicle is moving. The violent forces created during an accident will tear the child from your arms and throw the child against the interior of the vehicle.**

Small children are best protected from injury in an accident when properly restrained in the rear seat by a Child Restraint System that meets the requirements of the Safety Standards of your country. Before buying any Child Restraint System, make sure that it has a label certifying that it meets Safety Standard of your country. The Child Restraint System must be appropriate for your child's height and weight. Check the label on the Child Restraint System for this information. Refer to “Child Restraint Systems” in this chapter.

### Larger children

Children under age 13 and who are too large for a booster seat should always occupy the rear seat and use the available lap/shoulder belts. A seat belt should lie across the upper thighs and be snug across the shoulder and chest to restrain the child safely. Check belt fit periodically. A child's squirming could put the belt out of position. In the event of an accident, children are afforded the best safety restrained by a proper Child Restraint System in the rear seats.

If a larger child over age 13 must be seated in the front seat, the child must be securely restrained by the available lap/shoulder belt and the seat should be placed in the rear-most position.

If the shoulder belt portion slightly touches the child's neck or face, try placing the child closer to the center of the vehicle. If the shoulder belt still touches their face or neck, they need to be returned to an appropriate booster seat in the rear seat.

### WARNING

- **Always make sure larger children's seat belts are worn and properly adjusted.**
- **NEVER allow the shoulder belt to contact the child's neck or face.**
- **Do not allow more than one child to use a single seat belt.**

### ***Seat belt use and injured people***

A seat belt should be used when an injured person is being transported. Consult a physician for specific recommendations.

### ***One person per belt***

Two people (including children) should never attempt to use a single seat belt. This could increase the severity of injuries in case of an accident.

### ***Do not lie down***

Sitting in a reclined position when the vehicle is in motion can be dangerous. Even when buckled up, the protections of your restraint system (seat belts and/or air bags) is greatly reduced by reclining your seatback.

Seat belts must be snug against your hips and chest to work properly.

During an accident, you could be thrown into the seat belt, causing neck or other injuries.

The more the seat back is reclined, the greater the chance for the passenger's hips to slide under the lap belt or the passenger's neck to strike the shoulder belt.

 **WARNING**

- **NEVER ride with a reclined seatback when the vehicle is moving.**
- **Riding with a reclined seatback increases your chance of serious or fatal injuries in the event of a collision or sudden stop.**
- **Driver and passengers should always sit well back in their seats, properly belted, and with the seatbacks upright.**

## Care of seat belts

Seat belt systems should never be disassembled or modified. In addition, care should be taken to assure that seat belts and belt hardware are not damaged by seat hinges, doors or other abuse.

### *Periodic inspection*

All seat belts should be inspected periodically for wear or damage of any kind. Any damaged parts should be replaced as soon as possible.

### *Keep belts clean and dry*

Seat belts should be kept clean and dry. If belts become dirty, they can be cleaned by using a mild soap solution and warm water. Bleach, dye, strong detergents or abrasives should not be used because they may damage and weaken the fabric.

### *When to replace seat belts*

The entire seat belt assembly or assemblies should be replaced if the vehicle has been involved in an accident. This should be done even if no damage is visible. We recommend that you consult an authorized HYUNDAI dealer.



## CHILD RESTRAINT SYSTEM (CRS)

**Our recommendation:  
Children always in the rear**

### **WARNING**

**Always properly restrain children in the vehicle. Children of all ages are safer when riding in the rear seats. Never place a rearward-facing Child Restraint System on the front passenger seat, unless the air bag is deactivated.**

Children under age 13 should always ride in the rear seats and must always be properly restrained to minimize the risk of injury in an accident, sudden stop or sudden maneuver.

According to accident statistics, children are safer when properly restrained in the rear seats than in the front seat. Children too large for a Child Restraint System must use the seat belts provided.

Most countries have regulations which require children to travel in approved Child Restraint Systems.

The laws governing the age or height/weight restrictions at which seat belts can be used instead of Child Restraint System differs among countries, so you should be aware of the specific requirements in your country, and where you are travelling.

Child Restraint Systems must be properly installed in the vehicle seat. Always use a commercially available Child Restraint System that meets the requirements of your country.

### ***Child Restraint System (CRS)***

Infants and younger children must be restrained in an appropriate rearward-facing or forward-facing CRS that has first been properly secured to the seat of the vehicle. Read and comply with the instructions for installation and use provided by the manufacturer of the Child Restraint System.

### **WARNING**

- **Always follow the Child Restraint System manufacturer's instructions for installation and use.**
- **Always properly restrain your child in the Child Restraint System.**
- **Do not use an infant carrier or a child safety seat that "hooks" over a seatback, it may not provide adequate protection in an accident.**
- **After an accident, we recommend a HYUNDAI dealer to check the Child Restraint System, seat belts, ISOFIX anchorages and top-tether anchorages.**

## Selecting a Child Restraint System (CRS)

When selecting a Child Restraint System for your child, always:

- Make sure the Child Restraint System has a label certifying that it meets applicable Safety Standards of your country.

A Child Restraint System may only be installed if it was approved in accordance with the requirements of ECE-R44 or ECE-R129.

- Select a Child Restraint System based on your child's height and weight. The required label or the instructions for use typically provide this information.
- Select a Child Restraint System that fits the vehicle seating position where it will be used.

For the suitability of Child Restraint Systems on the vehicle's seating positions, please refer to the installation tables on pages 2-45, 48 and 49.

- Read and comply with the warnings and instructions for installation and use provided with the Child Restraint System.

### ***Child Restraint System types***

There are three main types of Child Restraint Systems: rearward-facing, forward-facing and booster Child Restraint Systems.

They are classified according to the child's age, height and weight.

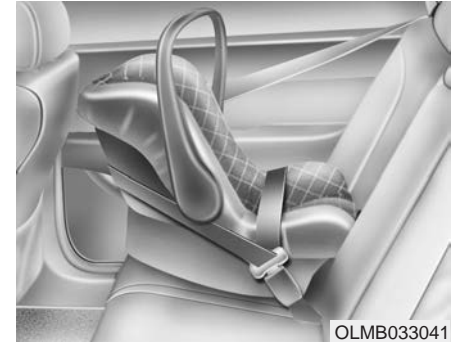

### **Rearward-facing Child Restraint System**

A rearward-facing Child Restraint System provides restraint with the seating surface against the back of the child. The harness system holds the child in place, and in an accident, acts to keep the child positioned in the Child Restraint Systems and reduce the stress to the fragile neck and spinal cord.

All children under the age of one year must always ride in a rearward-facing Child Restraint System. There are different types of rearward-facing Child Restraint Systems: infant-only Child Restraint Systems can only be used rearward-facing. Convertible and 3-in-1 Child Restraint Systems typically have higher height and weight limits for the rearward-facing position, allowing you to keep your child rearward-facing for a longer period of time.

Keep using Child Restraint Systems in the rearward-facing position as long as children fit within the height and weight limits allowed by the Child Restraint System's manufacturer.



### Forward-facing Child Restraint System

A forward-facing Child Restraint System provides restraint for the child's body with a harness. Keep children in a forward-facing Child Restraint System with a harness until they reach the top height or weight limit allowed by your Child Restraint System's manufacturer.

Once your child outgrows the forward-facing Child Restraint System, your child is ready for a booster seat.

### Booster seats

A booster seat is a Child Restraint System designed to improve the fit of the vehicle's seat belt system. A booster seat positions the seat belt so that it fits properly over the stronger parts of your child's body. Keep your children in booster seats until they are big enough to fit in a seat belt properly.

For a seat belt to fit properly, the lap belt must lie comfortable across the upper thighs, not the stomach. The shoulder belt should lie comfortable across the shoulder and chest and not across the neck or face. Children under age 13 must always be properly restrained to minimize the risk of injury in an accident, sudden stop or sudden maneuver.

## Installing a Child Restraint System (CRS)

### WARNING

**Before installing your Child Restraint System always:**

**Read and follow the instructions provided by the manufacturer of the Child Restraint System.**

**Failure to follow all warnings and instructions could increase the risk of the SERIOUS INJURY or DEATH if an accident occurs.**

### WARNING

**If the vehicle headrest prevents proper installation of a Child Restraint System, the headrest of the respective seating position shall be readjusted or entirely removed.**

After selecting a proper Child Restraint System for your child and checking that the Child Restraint System fits properly on the seating position, there are three general steps for a proper installation:

- **Properly secure the Child Restraint System to the vehicle.** All Child Restraint Systems must be secured to the vehicle with the lap belt or lap part of a lap/shoulder belt or with the ISOFIX top-tether and/or ISOFIX anchorage and/or with the support leg.
- **Make sure the Child Restraint System is firmly secured.** After installing a Child Restraint System to the vehicle, push and pull the seat forward and from side-to-side to verify that it is securely attached to the seat. A Child Restraint System secured with a seat belt should be installed as firmly as possible. However, some side-to-side movement can be expected.

When installing a Child Restraint System, adjust the vehicle seat and seatback (up and down, forward and rearward) so that your child fits in the Child Restraint System in a comfortable manner.

- **Secure the child in the Child Restraint System.** Make sure the child is properly strapped in the Child Restraint System according to the Child Restraint System manufacturer's instructions.

### CAUTION

**A Child Restraint System in a closed vehicle can become very hot. To prevent burns, check the seating surface and buckles before placing your child in the Child Restraint System.**

### ***ISOFIX anchorage and top-tether anchorage (ISOFIX anchorage system) for children***

The ISOFIX system holds a Child Restraint System during driving and in an accident. This system is designed to make installation of the Child Restraint System easier and reduce the possibility of improperly installing your Child Restraint System. The ISOFIX system uses anchors in the vehicle and attachments on the Child Restraint System. The ISOFIX system eliminates the need to use seat belts to secure the Child Restraint System to the rear seats.

ISOFIX anchorages are metal bars built into the vehicle. There are two lower anchors for each ISOFIX seating position that will accommodate a Child Restraint System with lower attachments.

To use the ISOFIX system in your vehicle, you must have a Child Restraint System with ISOFIX attachments.

The Child Restraint System manufacturer will provide you with instructions on how to use the Child Restraint System with its attachments for the ISOFIX anchorages.

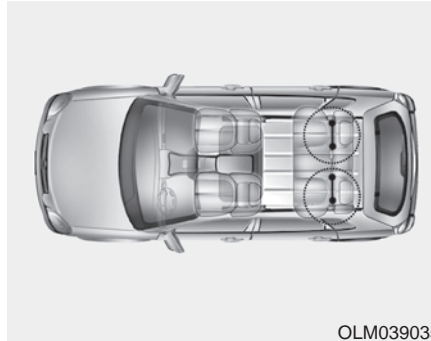

ISOFIX anchorages have been provided in the left and right outboard rear seating positions. Their locations are shown in the illustration.

### **⚠ WARNING**

**Do not attempt to install a Child Restraint System using ISOFIX anchorages in the rear center seating position. There are no ISOFIX anchorages provided for this seat. Using the outboard seat anchorages, for the CRS installation on the rear center seating position, can damage the anchorages.**

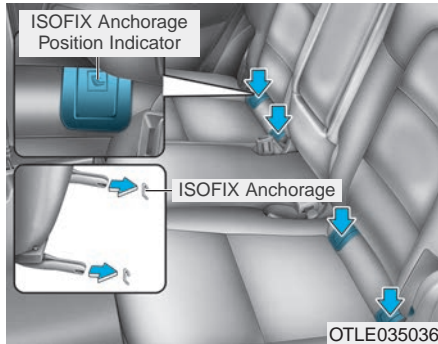

ISOFIX anchorages are located between the seatback and the seat cushion of the rear seat left and right outboard seating positions, indicated by the symbols .

To use the ISOFIX anchorages, push the upper portion of the ISOFIX anchorage cover.

### **Securing a Child Restraint System with the “ISOFIX Anchorage System”**

To install an i-Size or ISOFIX-compatible Child Restraint System in either of the rear outboard seating positions:

1. Move the seat belt buckle away from the ISOFIX anchorages.
2. Move any other objects away from the anchorages that could prevent a secure connection between the Child Restraint System and the ISOFIX anchorages.
3. Place the Child Restraint System on the vehicle seat, then attach the seat to the ISOFIX anchorages according to the instructions provided by the Child Restraint System manufacturer.
4. Follow the instructions of the Child Restraint System's manufacturer for proper installation and connection of the ISOFIX attachments on the Child Restraint System to the ISOFIX anchorages.

### **⚠ WARNING**

Take the following precautions when using the ISOFIX system:

- Read and follow all installation instructions provided with your Child Restraint System.
- To prevent the child from reaching and taking hold of unretracted seat belts, buckle all unused rear seat belts and retract the seat belt webbing behind the child. Children can be strangled if a shoulder belt becomes wrapped around their neck and the seat belt tightens.
- NEVER attach more than one Child Restraint System to a single anchorage. This could cause the anchor or attachment to come loose or break.
- Always have the ISOFIX system inspected by your dealer after an accident. An accident can damage the ISOFIX system and may not properly secure the Child Restraint System.

### Securing a Child Restraint System seat with “Top-tether Anchorage” system

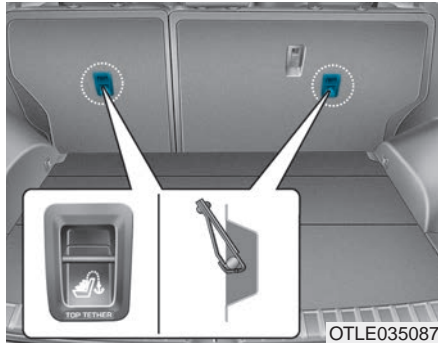

Top-tether anchorages for Child Restraint Systems are located on the rear of the seatbacks.

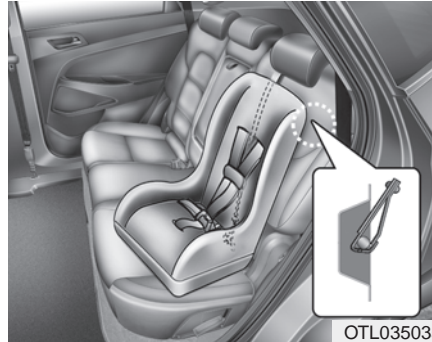

1. Route the Child Restraint System top-tether strap over the seatback. Placing the top tether strap, please follow the instructions of the Child Restraint System manufacturer.
2. Connect the top-tether strap to the top-tether anchorage, then tighten the top-tether strap according to the instructions of your Child Restraint System's manufacturer to firmly attach the Child Restraint System to the seat.

### WARNING

Take the following precautions when installing the top-tether:

- Read and follow all installation instructions provided with your Child Restraint System.
- **NEVER** attach more than one Child Restraint System to a single ISOFIX top-tether anchorage. This could cause the anchorage or attachment to come loose or break.
- Do not attach the top-tether to anything other than the correct top-tether anchorage. It may not work properly if attached to something else.
- Child Restraint System anchorages are designed to withstand only those loads imposed by correctly fitted Child Restraint System.

Under no circumstances are they to be used for adult seat belts or harnesses or for attaching other items or equipment to the vehicle.



### Suitability of each seating position for ISOFIX Child Restraint Systems according to ECE regulations

Mass Group	Size Class	Fixture	Vehicle ISOFIX Positions			
			Front Passenger	Rear Outboard (Driver side)	Rear Outboard (Passenger side)	Rear Center
Carycot	F	ISO/L1	-	X	X	-
	G	ISO/L2	-	X	X	-
0 : UP to 10kg	E	ISO/R1	-	IL	IL	-
0+ : UP to 13kg	E	ISO/R1	-	IL	IL	-
	D	ISO/R2	-	IL	IL	-
	C	ISO/R3	-	IL	IL	-
I : 9 to 18kg	D	ISO/R2	-	IL	IL	-
	C	ISO/R3	-	IL	IL	-
	B	ISO/F2	-	IUF + IL	IUF + IL	-
	B1	ISO/F2X	-	IUF + IL	IUF + IL	-
	A	ISO/F3	-	IUF + IL	IUF + IL	-

IUF = Suitable for ISOFIX Forward-Facing Child Restraint Systems of universal category approved for use in the mass group.

IL = Suitable for particular ISOFIX Child Restraint Systems given in the attached list. These ISOFIX CRS are those of the "specific vehicle", "restricted" or "semi-universal" categories.

X = ISOFIX position not suitable for ISOFIX Child Restraint System in this mass group and/or this size class.

\* Both ISO/R2 and ISO/R3 are able to be set up only at the foremost position of the passenger seat.

\* ISOFIX Child Restraint System size classes and fixtures

A - ISO/F3: Full-Height Forward-Facing toddler Child Restraint System (height 720mm)

B - ISO/F2: Reduced-Height Forward-Facing toddler Child Restraint System (height 650mm)

B1 - ISO/F2X: Reduced-Height Second Version Back Surface Shape Forward-Facing toddler Child Restraint System (height 650mm)

C - ISO/R3: Full-Size Rearward-Facing toddler Child Restraint System

D - ISO/R2: Reduced-Size Rearward-Facing toddler Child Restraint System

E - ISO/R1: Infant-Size Rearward-Facing Child Restraint System

F - ISO/L1: Left Lateral Facing position Child Restraint System (carry-cot)

G - ISO/L2: Right Lateral Facing position Child Restraint System (carry-cot)



### **Securing a Child Restraint System with a lap/shoulder belt**

When not using the ISOFIX system, all Child Restraint Systems must be secured to a rear seat with the lap part of a lap/shoulder belt.

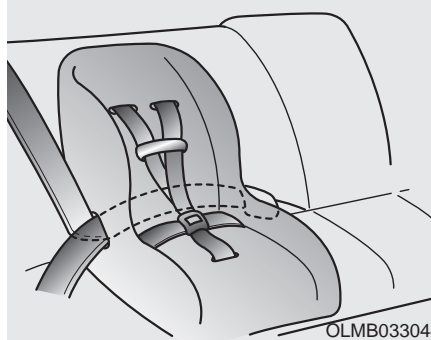

### **Installing a Child Restraint System with a lap/shoulder belt**

To install a Child Restraint System on the rear seats, do the following:

1. Place the Child Restraint System on a rear seat and route the lap/shoulder belt around or through the Child Restraint System, following the Child Restraint System manufacturer's instructions.

Make sure the seat belt webbing is not twisted.

### ***i* Information**

When using the rear center seat belt, you should also refer to the “3-point Rear Center Seat Belt” in this chapter.

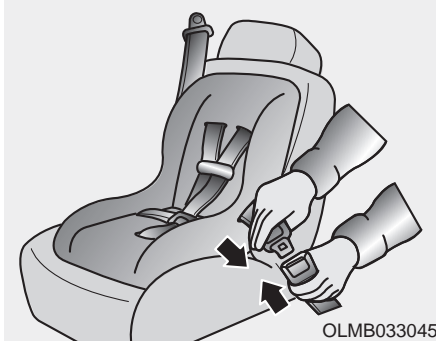

2. Fasten the lap/shoulder belt latch into the buckle. Listen for the distinct “click” sound.

### **i** Information

**Position the release button so that it is easy to access in case of an emergency.**



3. Remove as much slack from the belt as possible by pushing down on the Child Restraint System while feeding the shoulder belt back into the retractor.
4. Push and pull on the Child Restraint System to confirm that the seat belt is holding it firmly in place.

To remove the Child Restraint System, press the release button on the buckle and then pull the lap/shoulder belt out of the Child Restraint System and allow the seat belt to retract fully.

**Suitability of each seating position for "universal" category belted Child Restraint Systems according to ECE regulations**

Mass Group		Seating Position			
		Front passenger Outboard	Second Row		
			Outboard Left	Center (3 POINT BELT)	Outboard Right
Group 0 (0-9months)	up to 10kg	U*	U	U	U
Group 0 + (0-2years)	up to 13kg	U*	U	U	U
Group I (9months-4years)	9 to 18kg	U*	U	U	U
Group II (15 to 25kg)	15 to 25kg	U*	U	U	U
Group III (22 to 36kg)	22 to 36kg	U*	U	U	U

U : Suitable for "universal" category Child Restraint Systems approved for use in this mass group

U\* : Suitable for "universal" category Child Restraint Systems with seat back adjusted to the most upright position

***i-Size Child Restraint Systems according to ECE regulations***

Mass Group	Seating Position			
	Front passenger Outboard	Second Row		
		Outboard Left	Center	Outboard Right
i-size Child Restraint Systems	X	i-U	X	i-U

i-U : Suitable for i-Size "universal" Child Restraint Systems forward and rearward-facing

i-UF : Suitable for forward-facing i-Size "universal" Child Restraint Systems only

X : Seat position not suitable for i-size Child Restraint Systems

## AIR BAG – SUPPLEMENTAL RESTRAINT SYSTEM

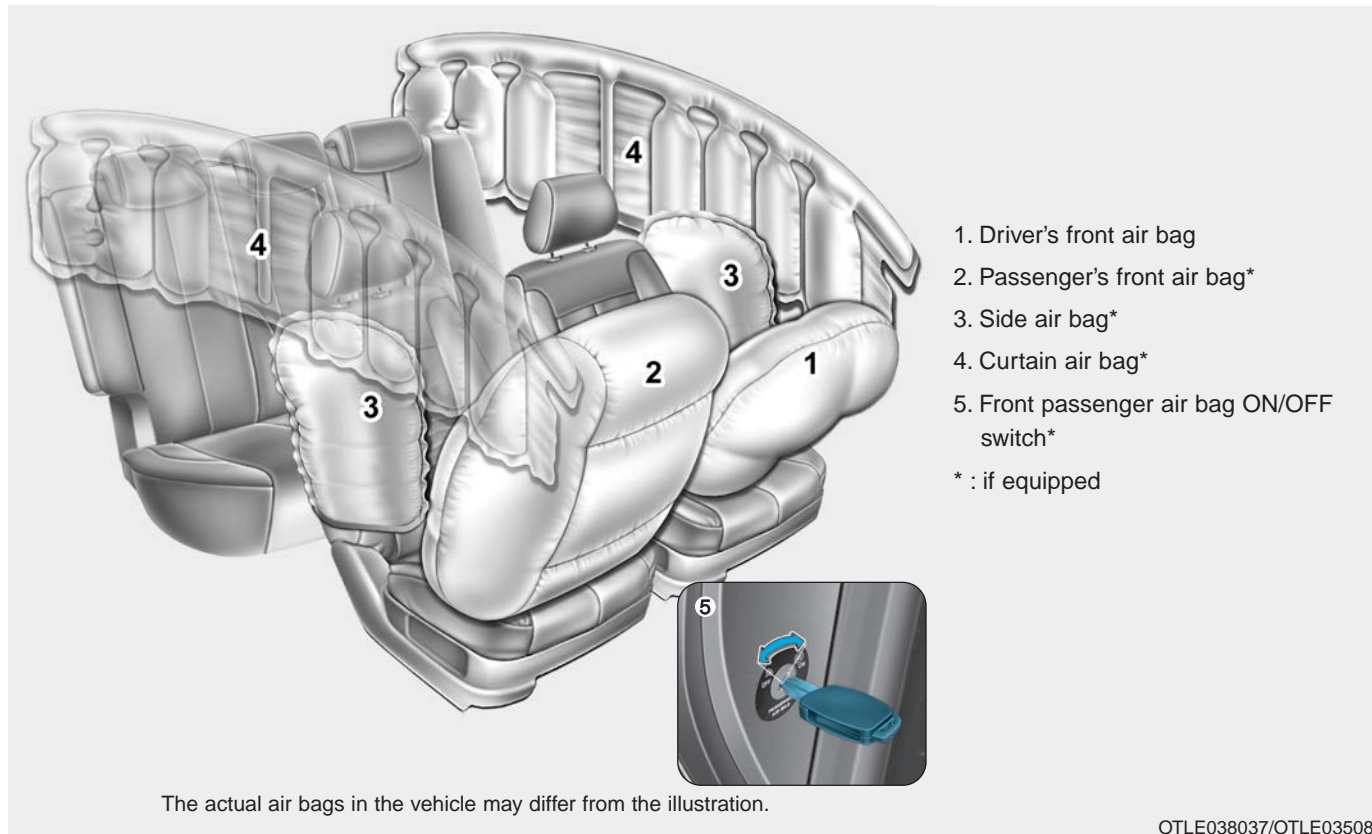

OTLE038037/OTLE035081

The vehicles are equipped with a Supplemental Air Bag System for the driver's seat and front passenger's seats.

The front air bags are designed to supplement the three-point seat belts. For these air bags to provide protection, the seat belts must be worn at all times when driving.

You can be severely injured or killed in an accident if you are not wearing a seat belt. Air bags are designed to supplement seat belts, but do not replace them. Also, air bags are not designed to deploy in every collision. In some accidents, the seat belts are the only restraint protecting you.

## WARNING

### AIR BAG SAFETY PRECAUTIONS

**ALWAYS** use seat belts Child Restraint Systems - every trip, every time, everyone! Even with air bags, you can be seriously injured or killed in a collision if you are improperly belted or not wearing your seat belt when the air bag inflates.

**NEVER** place a child in any Child Restraint System or booster seat in the front passenger seat, unless the air bag is deactivated.

**An inflating air bag could forcefully strike the infant or child causing serious or fatal injuries.**

**ABC - Always Buckle Children under age 13 in the back seat. It is the safest place for children of any age to ride. If a child age 13 or older must be seated in the front seat, he or she must be properly belted and the seat should be moved as far back as possible.**

**All occupants should sit upright with the seatback in an upright position, centered on the seat cushion with their seat belt on, legs comfortably extended and their feet on the floor until the vehicle is parked and the engine is turned off. If an occupant is out of position during an accident, the rapidly deploying air bag may forcefully contact the occupant causing serious or fatal injuries.**

**You and your passengers should never sit or lean unnecessarily close to the air bags or lean against the door or center console.**

**Move your seat as far back as possible from front air bags, while still maintaining control of the vehicle.**

### Where are the air bags?

#### *Driver's and passenger's front air bags (if equipped)*

■ Driver's front air bag



■ Passenger's front air bag



Your vehicle is equipped with a Supplemental Restraint System (SRS) and lap/shoulder belts at both the driver and passenger seating positions.

The SRS consists of air bags which are located in the center of the steering wheel and the passenger's side front panel pad above the glove box.

The air bags are labeled with the letters "AIR BAG" embossed on the pad covers.

The purpose of the SRS is to provide the vehicle's driver and front passengers with additional protection than that offered by the seat belt system alone in case of a frontal impact of sufficient severity.

#### **⚠ WARNING**

**To reduce the risk of serious injury or death from inflating front air bags, take the following precautions:**

- **Seat belts must be worn at all times to help keep occupants positioned properly.**

**(Continued)**

#### **(Continued)**

- **Move your seat as far back as possible from front air bags, while still maintaining control of the vehicle.**
- **Never lean against the door or center console.**
- **Do not allow the front passenger to place their feet or legs on the dashboard.**
- **No objects (such as crash pad cover, cellular phone holder, cup holder, perfume or stickers) should be placed over or near the air bag modules on the steering wheel, instrument panel, windshield glass, and the front passenger's panel above the glove box. Such objects could cause harm if the vehicle is in a crash severe enough to cause the air bags to deploy.**
- **Do not attach any objects on front windshield and inside mirror.**



OTLE035081

### Passenger's front air bag ON/OFF switch (if equipped)

The purpose of the switch is to disable the passenger's front air bag in order to transport occupants who are at increased risk for air bag-related injury due to age, size, or medical condition.

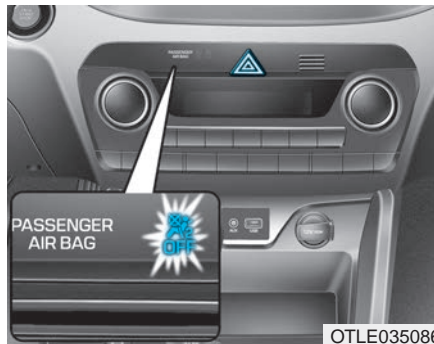

OTLE035086

To deactivate the passenger's front air bag:

Insert the key or a similar rigid device into the passenger's front air bag ON/OFF switch and turn it to the OFF position. The passenger air bag OFF indicator (⚠️) will illuminate and stay on until the passenger's front air bag is reactivated.

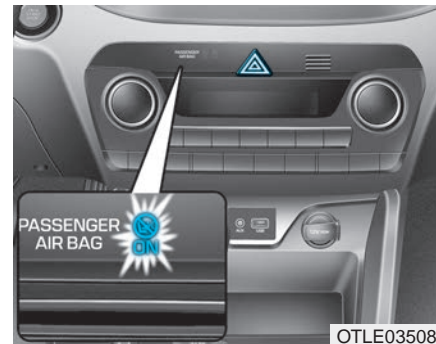

OTLE035085

To reactivate the passenger's front air bag:

Insert the key or a similar rigid device into the passenger's front air bag ON/OFF switch and turn it to the ON position. The passenger air bag ON indicator (⊗) will illuminate and stay on for 60 seconds.

### **i** Information

**The passenger's front air bag ON/OFF indicator illuminates for about 4 seconds after the ignition switch is placed in the ON position.**





**⚠ WARNING**

Never allow an adult passenger to ride in the front passenger seat when the passenger air bag OFF indicator is illuminated. During a collision, the air bag will not inflate if the indicator is illuminated. Turn on the passenger's front air bag or have your passenger move to the rear seat.

**⚠ WARNING**

If the passenger's front air bag ON/OFF switch malfunctions, the following conditions may occur:

- The air bag warning light (  ) on the instrument panel will illuminate.
- The passenger air bag OFF indicator (  ) will not illuminate and the ON indicator (  ) will come on and go off after approximately 60 seconds. The passenger's front air bag will inflate in a frontal impact even though the passenger's front air bag ON/OFF switch is set to the OFF position.
- We recommend that an authorized HYUNDAI dealer inspect the passenger's front air bag ON/OFF switch and the SRS air bag system as soon as possible.

**Side air bags (if equipped)**

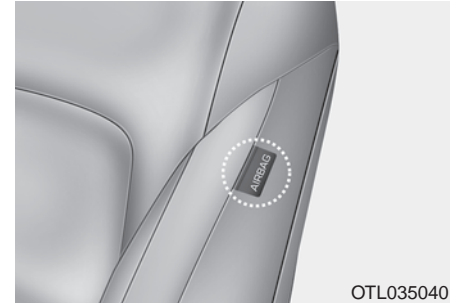

OTL035040

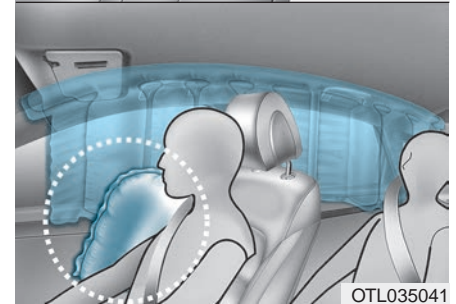

OTL035041

Your vehicle is equipped with a side air bag in each front seat. The purpose of the air bag is to provide the vehicle's driver and the front passenger with additional protection than that offered by the seat belt alone.

The side air bags are designed to deploy during certain side impact collisions, depending on the crash severity, angle, speed and point of impact.

The side air bags on both sides of the vehicle are designed to deploy when a rollover is detected by a rollover sensor. (if equipped with rollover sensor)

The side air bags are not designed to deploy in all side impact or rollover situations.

### WARNING

To reduce the risk of serious injury or death from an inflating side air bag, take the following precautions:

- Seat belts must be worn at all times to help keep occupants positioned properly.

(Continued)

### (Continued)

- Do not allow passengers to lean their heads or bodies onto doors, put their arms on the doors, stretch their arms out of the window, or place objects between the doors and seats.
- Hold the steering wheel at the 9 o'clock and 3 o'clock positions, to minimize the risk of injuries to your hands and arms.
- Do not use any accessory seat covers. This could reduce or prevent the effectiveness of the system.
- Do not place any objects over the air bag or between the air bag and yourself. Also, do not attach any objects around the area the air bag inflates such as the door, side door glass, front and rear pillar.

(Continued)

### (Continued)

- Do not place any objects between the door and the seat. They may become dangerous projectiles if the side air bag inflates.
- Do not install any accessories on the side or near the side air bags.
- Do not put any objects between the side air bag label and seat cushion. It could cause harm if the vehicle is in a crash severe enough to cause the air bags to deploy.
- Do not cause impact to the doors when the ignition switch is in the ON position or this may cause the side air bags to inflate.
- If the seat or seat cover is damaged, we recommend that the system be serviced by an authorized HYUNDAI dealer.

### Curtain air bags (if equipped)

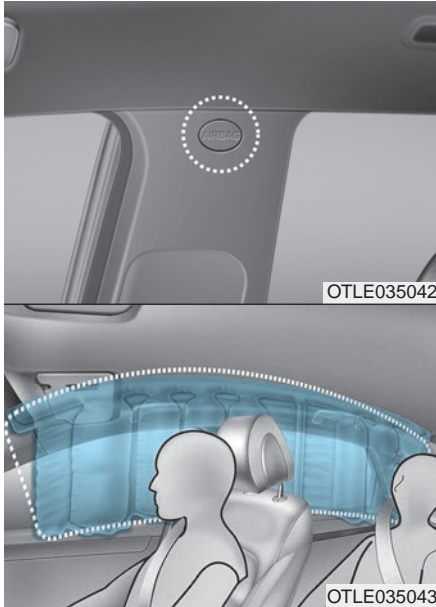

Curtain air bags are located along both sides of the roof rails above the front and rear doors.

They are designed to help protect the heads of the front seat occupants and the rear outboard seat occupants in certain side impact collisions.

The curtain air bags are designed to deploy during certain side impact collisions, depending on the crash severity, angle, speed and impact.

The curtain air bags on both sides of the vehicle are designed to deploy when a rollover is detected by a rollover sensor. (if equipped with rollover sensor)

The curtain air bags are not designed to deploy in all side impact or rollover situations.

#### **WARNING**

**To reduce the risk of serious injury or death from an inflating curtain air bags, take the following precautions:**

- **All seat occupants must wear seat belts at all times to help keep occupants positioned properly.**

**(Continued)**

#### **(Continued)**

- **Properly secure Child Restraint System as far away from the door as possible.**
- **Do not place any objects over the air bag. Also, do not attach any objects around the area the air bag inflates such as the door, side door glass, front and rear pillar, roof side rail.**
- **Do not hang other objects except clothes, especially hard or breakable objects. In an accident, it may cause vehicle damage or personal injury.**
- **Do not allow passengers to lean their heads or bodies onto doors, put their arms on the doors, stretch their arms out of the window, or place objects between the doors and seats.**
- **Do not open or repair the side curtain air bags.**

## How does the air bags system operate?

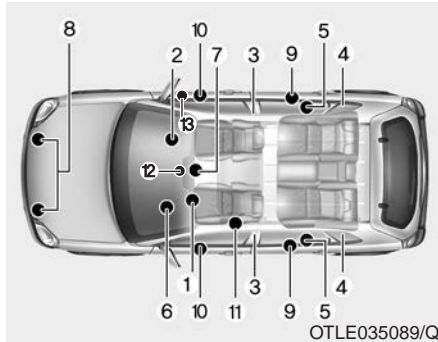

The SRS consists of the following components:

- (1) Driver's front air bag module
- (2) Passenger's front air bag module
- (3) Side air bag modules
- (4) Curtain air bag modules
- (5) Retractor pre-tensioner assemblies
- (6) Air bag warning light
- (7) SRS control module (SRSCM)/ Rollover sensor
- (8) Front impact sensors

- (9) Side impact sensors
- (10) Side pressure sensors
- (11) Emergency Fastening Device (EFD)
- (12) Passenger's front air bag OFF indicator (front passenger's seat only)
- (13) Passenger's front air bag ON/OFF switch

The SRSCM continually monitors all SRS components while the ignition switch is ON to determine if a crash impact is severe enough to require air bag deployment or pre-tensioner seat belt deployment.



## SRS warning light

The SRS (Supplement Restraint System) air bag warning light on the instrument panel displays the air bag symbol depicted in the illustration. The system checks the air bag electrical system for malfunctions. The light indicates that there is a potential problem with your air bag system, which could include your side and/or curtain air bags used for rollover protection (if equipped with rollover sensor).

### **WARNING**

**If your SRS malfunctions, the air bag may not inflate properly during an accident increasing the risk of serious injury or death.**

**If any of the following conditions occur, your SRS is malfunctioning:**

- **The light does not turn on for approximately six seconds when the ignition switch is in the ON position.**
- **The light stays on after illuminating for approximately six seconds.**
- **The light comes on while the vehicle is in motion.**
- **The light blinks when the engine is running.**

**We recommend that an authorized HYUNDAI dealer inspect the SRS as soon as possible if any of these conditions occur.**

During a moderate to severe frontal collision, sensors will detect the vehicle's rapid deceleration. If the rate of deceleration is high enough, the control unit will inflate the front air bags, at the time and with the force needed.

The front air bags help protect the driver and front passenger by responding to frontal impacts in which seat belts alone cannot provide adequate restraint. When needed, the side air bags help provide protection in the event of a side impact or rollover by supporting the side upper body area.

- Air bags are activated (able to inflate if necessary) only when the ignition switch is in the ON position.
- Air bags inflate in the event of certain frontal or side collisions to help protect the occupants from serious physical injury.
- There is no single speed at which the air bags will inflate. Generally, air bags are designed to inflate based upon the severity of a collision and its direction. These two factors determine whether the sensors produce an electronic deployment/inflation signal.

- Air bag deployment depends on a number of factors including vehicle speed, angles of impact and the density and stiffness of the vehicles or objects which your vehicle impacts during a collision. The determining factors are not limited to those mentioned above.

- The front air bags will completely inflate and deflate in an instant. It is virtually impossible for you to see the air bags inflate during an accident. It is much more likely that you will simply see the deflated air bags hanging out of their storage compartments after the collision.

- In addition to inflating in serious side collisions, vehicles equipped with a rollover sensor, side and/or curtain air bags will inflate if the sensing system detects a rollover.

When a rollover is detected, curtain air bags will remain inflated longer to help provide protection from ejection, especially when used in conjunction with the seat belts. (if equipped with a rollover sensor)

- To help provide protection, the air bags must inflate rapidly. The speed of air bag inflation is a consequence of extremely short time in which to inflate the air bag between the occupant and the vehicle structures before the occupant impacts those structures. This speed of inflation reduces the risk of serious or life-threatening injuries and is thus a necessary part of air bag design.

However, the rapid air bag inflation can also cause injuries which can include facial abrasions, bruises and broken bones because the inflation speed also causes the air bags to expand with a great deal of force.

- There are even circumstances under which contact with the air bag can cause fatal injuries, especially if the occupant is positioned excessively close to the air bag.

You can take steps to reduce the risk of being injured by an inflating air bag. The greatest risk is sitting too close to the air bag. An air bag needs space to inflate. It is recommended that drivers sit as far as possible between the center of the steering wheel and the chest while still maintaining control of the vehicle.



When the SRSCM detects a sufficiently severe impact to the front of the vehicle, it will automatically deploy the front air bags.

■ Driver's front air bag (2)



Upon deployment, tear seams molded directly into the pad covers will separate under pressure from the expansion of the air bags. Further opening of the covers allows full inflation of the air bags.

A fully inflated air bag, in combination with a properly worn seat belt, slows the driver's or the front passenger's forward motion, reducing the risk of head and chest injury.

■ Driver's front air bag (3)

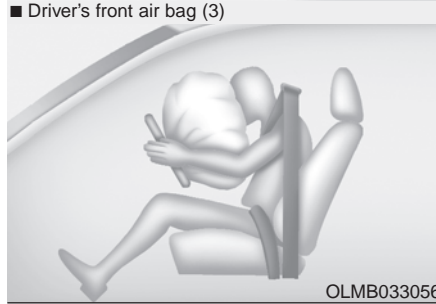

■ Passenger's front air bag



After complete inflation, the air bag immediately starts deflating, enabling the driver to maintain forward visibility and the ability to steer or operate other controls.

### **WARNING**

To prevent objects from becoming dangerous projectiles when the passenger's air bag inflates:

- Do not install or place any objects (drink holder, CD holder, stickers, etc.) on the front passenger's panel above the glove box where the passenger's air bag is located.
- Do not install a container of liquid air freshener near the instrument cluster or on the instrument panel surface.

## What to expect after an air bag inflates

After a frontal or side air bag inflates, it will deflate very quickly. Air bag inflation will not prevent the driver from seeing out of the windshield or being able to steer. Curtain air bags may remain partially inflated for some time after they deploy.

### WARNING

**After an air bag inflates, take the following precautions:**

- **Open your windows and doors as soon as possible after impact to reduce prolonged exposure to the smoke and powder released by the inflating air bag.**
- **Do not touch the air bag storage area's internal components immediately after an air bag has inflated. The parts that come into contact with an inflating air bag may be very hot.**

**(Continued)**

**(Continued)**

- **Always wash exposed skin areas thoroughly with cold water and mild soap.**
- **We recommend that an authorized HYUNDAI dealer replace the air bag immediately after deployment. Air bags are designed to be used only once.**



### Noise and smoke from inflating air bag

When the air bags inflate, they make a loud noise and may produce smoke and powder in the air inside of the vehicle. This is normal and is a result of the ignition of the air bag inflator. After the air bag inflates, you may feel substantial discomfort in breathing because of the contact of your chest with both the seat belt and the air bag, as well as from breathing the smoke and powder. The powder may aggravate asthma for some people. If you experience breathing problems after an air bag deployment, seek medical attention immediately.

Though the smoke and powder are nontoxic, they may cause irritation to the skin, eyes, nose, throat, etc. If this is the case, wash and rinse with cold water immediately and seek medical attention if the symptoms persist.

### Do not install a Child Restraint System on the front passenger seat

■ Type A



OYDESA2042

■ Type B

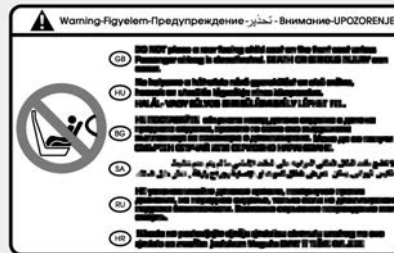

OLM034310

Never install a Child Restraint System in the front passenger seat, unless the air bag is deactivated

### ⚠ WARNING

**NEVER** use a rearward facing Child Restraint on a seat protected by an **ACTIVE AIRBAG** in front of it, **DEATH** or **SERIOUS INJURY** to the **CHILD** can occur.

## Why didn't my air bag go off in a collision?

There are certain types of accidents in which the air bag would not be expected to provide additional protection. These include rear impacts, second or third collisions in multiple impact accidents, as well as low speed impacts. Damage to the vehicle indicates a collision energy absorption, and is not an indicator of whether or not an air bag should have inflated.

### *Air bag collision sensors*

#### **WARNING**

**To reduce the risk of an air bag deploying unexpectedly and causing serious injury or death:**

- Do not hit or allow any objects to impact the locations where air bags or sensors are installed.
- Do not perform maintenance on or around the air bag sensors. If the location or angle of the sensors is altered, the air bags may deploy when they should not or may not deploy when they should.
- Do not install bumper guards or replace the bumper with a non-genuine part. This may adversely affect the collision and air bag deployment performance.

(Continued)

(Continued)

- Place the ignition switch to the LOCK/OFF or ACC position, when the vehicle is being towed to prevent inadvertent air bag deployment.
- We recommend that all air bag repairs are conducted by an authorized HYUNDAI dealer.

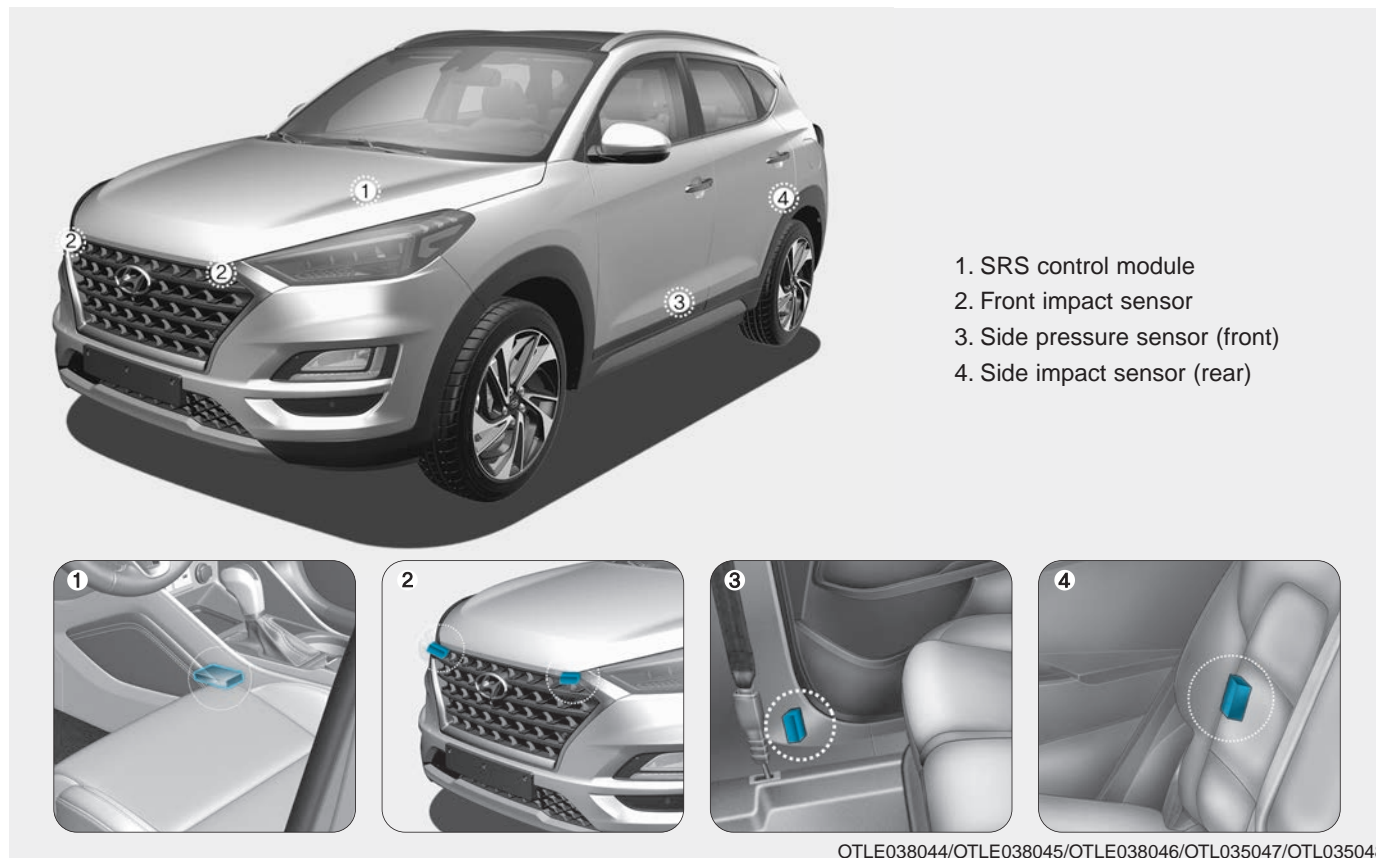

OTLE038044/OTLE038045/OTLE038046/OTL035047/OTL035048

## Air bag inflation conditions



### Front air bags

Front air bags are designed to inflate in a frontal collision depending on the severity, speed or angles of impact of the front collision.

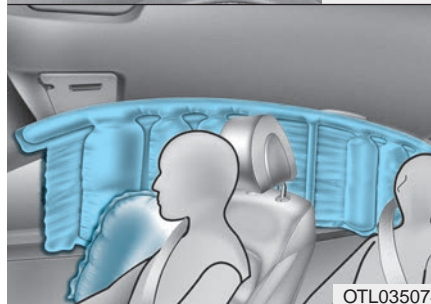

### Side and curtain air bags

Side and curtain air bags are designed to inflate when an impact is detected by side collision sensors depending on the severity, speed or angles of impact resulting from a side impact collision.

Although the driver's and front passenger's air bags are designed to inflate in frontal collisions, they also may inflate in other types of collisions if the front impact sensors detect a sufficient impact. Side and curtain air bags are designed to inflate in side impact collisions, but they may inflate in other collisions if the side impact sensors detect a sufficient impact.

Also, the side and curtain air bags are designed to inflate when a rollover is detected by a rollover sensor. (if equipped with rollover sensor)

If the vehicle chassis is impacted by bumps or objects on unimproved roads, the air bags may deploy. Drive carefully on unimproved roads or on surfaces not designed for vehicle traffic to prevent unintended air bag deployment.

### Air bag non-inflation conditions



In certain low-speed collisions the air bags may not deploy. The air bags are designed not to deploy in such cases because they may not provide benefits beyond the protection of the seat belts.

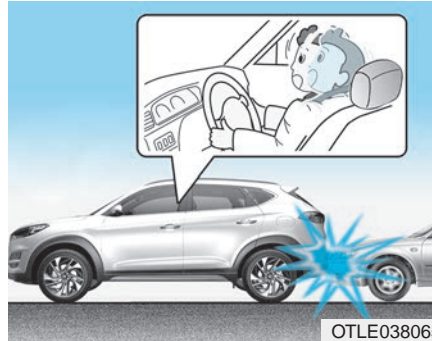

Front air bags are not designed to inflate in rear collisions, because occupants are moved backward by the force of the impact. In this case, inflated air bags would not provide any additional benefit.



Front air bags may not inflate in side impact collisions, because occupants move in the direction of the collision, and thus in side impacts, front air bag deployment would not provide additional occupant protection.

However, side and curtain air bags may inflate depending on the severity, vehicle speed and angles of impact.

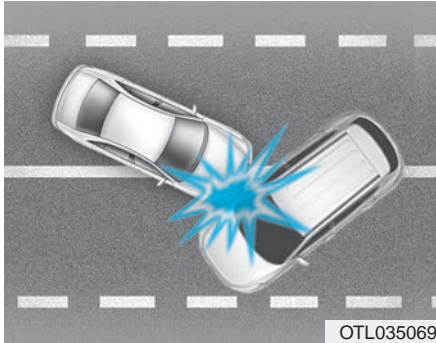

OTL035069

In an angled collision, the force of impact may direct the occupants in a direction where the air bags would not be able to provide any additional benefit, and thus the sensors may not deploy any air bags.

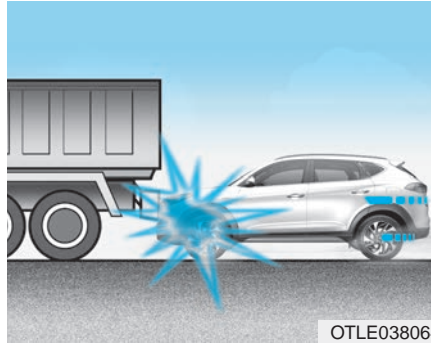

OTLE038064

Just before impact, drivers often brake heavily. Such heavy braking lowers the front portion of the vehicle causing it to “ride” under a vehicle with a higher ground clearance. Air bags may not inflate in this “under-ride” situation because deceleration forces that are detected by sensors may be significantly reduced by such “underride” collisions.

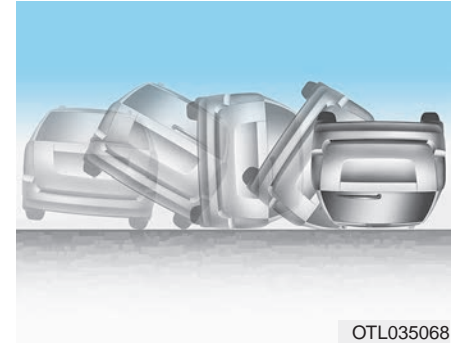

OTL035068

Front air bags may not inflate in rollover accidents because front air bag deployment would not provide additional occupant protection.

### **i** Information

- **Vehicles equipped with rollover sensor**  
The side and curtain air bags may inflate in a rollover situation, when it is detected by the rollover sensor.
- **Vehicles not equipped with rollover sensor**  
The side and/or curtain air bags may inflate when the vehicle is rolled over by a side impact collision, if the vehicle is equipped with side and/or curtain air bags.





Air bags may not inflate if the vehicle collides with objects such as utility poles or trees, where the point of impact is concentrated and the collision energy is absorbed by the vehicle structure.

### SRS care

The SRS is virtually maintenance-free and there are no parts you can safely service by yourself. If the SRS air bag warning light does not illuminate when the ignition switch is in the ON position, or continuously remains on, we recommend that the system be immediately inspected by an authorized HYUNDAI dealer.

We recommend any work on the SRS system, such as removing, installing, repairing, or any work on the steering wheel, the front passenger's panel, front seats and roof rails be performed by an authorized HYUNDAI dealer. Improper handling of the SRS system may result in serious personal injury.

### **WARNING**

**To reduce the risk of serious injury or death take the following precautions:**

- **Do not attempt to modify or disconnect the SRS components or wiring, including the addition of any kind of badges to the pad covers or modifications to the body structure.**

**(Continued)**

### **(Continued)**

- **Do not place objects over or near the air bag modules on the steering wheel, instrument panel, and the front passenger's panel above the glove box.**
- **Clean the air bag pad covers with a soft cloth moistened with plain water. Solvents or cleaners could adversely affect the air bag covers and proper deployment of the system.**
- **We recommend that inflated air bags be replaced by an authorized HYUNDAI dealer.**
- **If components of the air bag system must be discarded, or if the vehicle must be scrapped, certain safety precautions must be observed. Consult an authorized HYUNDAI dealer for the necessary information. Failure to follow these precautions could increase the risk of personal injury.**

## Additional safety precautions

**Passengers should not move out of or change seats while the vehicle is moving.** A passenger who is not wearing a seat belt during a crash or emergency stop can be thrown against the inside of the vehicle, against other occupants, or be ejected from the vehicle.

**Do not use any accessories on seat belts.** Devices claiming to improve occupant comfort or reposition the seat belt can reduce the protection provided by the seat belt and increase the chance of serious injury in a crash.

### **Do not modify the front seats.**

Modification of the front seats could interfere with the operation of the supplemental restraint system sensing components or side air bags.

**Do not place items under the front seats.** Placing items under the front seats could interfere with the operation of the supplemental restraint system sensing components and wiring harnesses.

**Do not cause impact to the doors.** Impact to the doors when the ignition switch is in the ON position may cause the air bags to inflate.

## *Adding equipment to or modifying your air bag equipped vehicle*

If you modify your vehicle by changing your vehicle's frame, bumper system, front end or side sheet metal or ride height, this may affect the operation of your vehicle's air bag system.

## Air bag warning labels

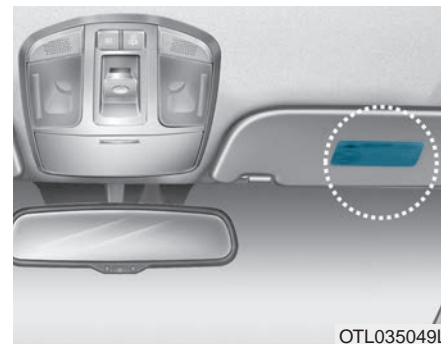

Air bag warning labels are attached to alert the passengers of potential risks of the air bag system.

Be sure to read all of the information about the air bags that are installed on your vehicle in this Owner's Manual.



## ACTIVE HOOD LIFT SYSTEM (IF EQUIPPED)

The active hood lift system can reduce a risk of injury to pedestrians by raising the hood in certain accident situations. The active hood lift system has the additional deformation space under the hood, which is made available for subsequent head impact.

The active hood lift system is activated in the following situations:

- The ignition switch is in the on position and the vehicle speed is approximately between 25 km/h (15.5 mph) and 50 km/h (31 mph).
- The active hood lift system is designed to work in a frontal collision depending on the intensity, speed or angles of impact of the front collision.

### **i** Information

- **Do not arbitrarily repair the active hood lift system after its activation. We recommend you to have the system repaired by an authorized HYUNDAI dealer.**
- **If you change or repair the front bumper, we recommend that the system be checked by an authorized HYUNDAI dealer.**

### Possible activation situations

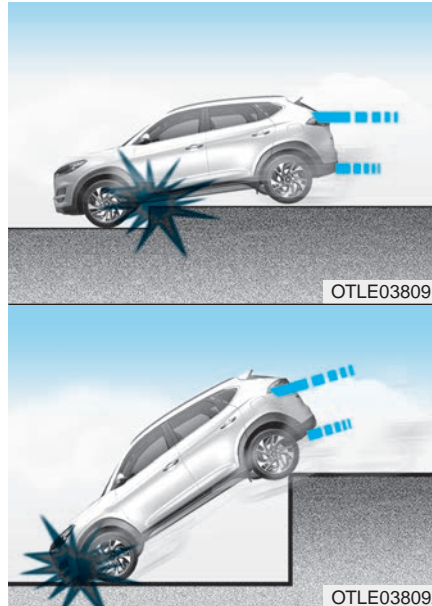

- The vehicle falls from a high location, such as falling into the gutter.
- The vehicle is involved in a certain high-speed frontal/angled collision, striking other vehicles or barriers.

### **i** Information

**An impact may be detected in a frontal collision with animals, trash cans or others, not with pedestrians.**

## Non-activation situations



- The vehicle is involved in a side/rear collision or a rollover. The active hood lift system activates only in a frontal collision.



- The vehicle is involved in an angled frontal collision, striking the pedestrian.



- The pedestrian lies on the road.
- The front bumper is damaged or modified.
- The pedestrian has an object to absorb shocks, such as a suit case, a cart, or a stroller.

### System malfunction

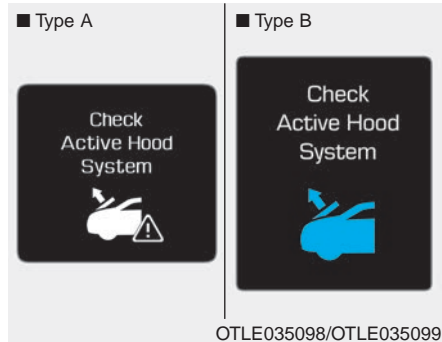

The warning message appears on the LCD display, when there is a malfunction with the active hood lift system.

The warning message indicates that the active hood lift system may not properly operate to protect the pedestrians.

In this case, we recommend you to immediately have the system checked by an authorized HYUNDAI dealer.

### NOTICE

The below situations may cause a malfunction with the active hood lift system.

- Do not remove or change the components and the wiring of the active hood system.
- Do not change the front bumper or the body structure.
- Do not install or assemble any aftermarket accessory on the front bumper or cover.
- When replacing tires, make sure they are the same size as your original tires. If you drive with different tire or wheel sizes, the active hood lift system may not work normally.

## Convenient features of your vehicle

Accessing your vehicle .....	3-4	Panorama sunroof .....	3-37
Remote key .....	3-4	Sunshade .....	3-38
Smart key .....	3-8	Sliding the sunroof .....	3-38
Immobilizer system .....	3-13	Tilting the sunroof .....	3-39
Door locks .....	3-14	Closing the sunroof .....	3-39
Operating door locks from outside the vehicle .....	3-14	Resetting the sunroof .....	3-41
Operating door locks from inside the vehicle .....	3-16	Sunroof open warning .....	3-41
Deadlocks .....	3-18	Exterior features .....	3-42
Auto door lock/unlock features .....	3-18	Hood .....	3-42
Child-protector rear door locks .....	3-19	Fuel filler door .....	3-44
Theft-alarm system .....	3-20	Tailgate .....	3-47
Steering wheel .....	3-22	Non-power tailgate .....	3-47
Electric power steering (EPS) .....	3-22	Power tailgate .....	3-49
Tilt steering / Telescope steering .....	3-23	Smart tailgate .....	3-56
Heated steering wheel .....	3-24	Instrument cluster .....	3-60
Horn .....	3-24	Instrument cluster control .....	3-62
Mirrors .....	3-25	Gauges .....	3-62
Inside rearview mirror .....	3-25	Icy Road Warning Light .....	3-65
Outside rearview mirror .....	3-29	Transaxle Shift Indicator .....	3-65
Windows .....	3-32	Odometer .....	3-67
Power windows .....	3-32	Distance to empty .....	3-68

LCD Display .....	3-68	Defroster .....	3-139
LCD display control .....	3-68	Rear window defroster .....	3-139
LCD modes .....	3-69	<b>Manual climate control system</b> .....	<b>3-140</b>
Warning messages .....	3-79	Heating and air conditioning.....	3-141
<b>Trip computer</b> .....	<b>3-87</b>	System operation.....	3-145
Trip modes .....	3-87	System maintenance.....	3-148
<b>Warning and indicator lights</b> .....	<b>3-93</b>	<b>Automatic climate control system</b> .....	<b>3-150</b>
Warning lights .....	3-93	Automatic heating and air conditioning.....	3-151
Indicator lights.....	3-104	Manual heating and air conditioning.....	3-152
<b>Light</b> .....	<b>3-110</b>	System operation.....	3-158
Exterior lights .....	3-110	System maintenance.....	3-160
Low Beam Assist-Static light .....	3-120	<b>Windshield defrosting and defogging</b> .....	<b>3-163</b>
Welcome system .....	3-120	Manual climate control system .....	3-163
Interior lights.....	3-121	Automatic climate control system.....	3-164
<b>Wipers and washers</b> .....	<b>3-125</b>	Defogging logic .....	3-165
Windshield wipers .....	3-126	<b>Climate control additional features</b> .....	<b>3-167</b>
Windshield washers .....	3-127	Cluster ionizer (Except Europe).....	3-167
Rear window wiper and washer switch .....	3-128	Automatic ventilation .....	3-167
<b>Driver Assist System</b> .....	<b>3-129</b>	Sunroof inside air recirculation .....	3-167
Parking Distance Warning (Reverse) system .....	3-129		
Parking Distance Warning (Reverse/Forward) system .....	3-132		
Rear View Monitor .....	3-136		
Surround View Monitor .....	3-137		

- Storage compartment.....3-168**
  - Center console storage .....3-168
  - Sliding armrest .....3-168
  - Glove box .....3-169
  - Cool box .....3-169
  - Sunglass holder .....3-169
- Interior features.....3-171**
  - Ashtray .....3-171
  - Cup holder.....3-171
  - Sunvisor .....3-172
  - Power outlet .....3-173
  - USB charger .....3-174
  - Wireless cellular phone charging system .....3-175
  - Cigarette lighter .....3-177
  - Clock.....3-177
  - Clothes hanger .....3-178
  - Floor mat anchor(s) .....3-178
  - Luggage net (holder) .....3-179
  - Cargo security screen .....3-180
  - Luggage tray .....3-182
- Exterior features .....3-183**
  - Roof rack .....3-183

## ACCESSING YOUR VEHICLE

### Remote key (if equipped)



Your HYUNDAI uses a remote key, which you can use to lock or unlock a door (and tailgate) and even start the engine.

1. Door Lock
2. Door Unlock
3. Tailgate Unlock

### Locking

To lock :

1. Close all doors, engine hood and tailgate.
2. Press the Door Lock button (1) on the remote key.
3. The doors will lock. The hazard warning lights will blink. Also, the outside rearview mirror will fold, if the outside rearview mirror folding switch is in the AUTO position (if equipped).
4. Make sure the doors are locked by checking the position of the door lock button inside the vehicle.

### WARNING

**Do not leave the keys in your vehicle with unsupervised children. Unattended children could place the key in the ignition switch and may operate power windows or other controls, or even make the vehicle move, which could result in serious injury or death.**

### Unlocking

To unlock:

1. Press the Door Unlock button (2) on the remote key.
2. The doors will unlock. The hazard warning lights will blink two times. Also, the outside rearview mirror will unfold, if the outside rearview mirror folding switch is in the AUTO position (if equipped).

### Information

**After unlocking the doors, the doors will lock automatically after 30 seconds unless a door is opened.**

## Tailgate unlocking

To unlock:

1. Press the Tailgate Unlock button (3) on the remote key for more than one second.
2. The hazard warning lights will blink two times. The tailgate will unlock. The power tailgate will unlock and then open (if equipped).

For more details, refer to “Power tailgate” in this chapter.

### **i** Information

The word "HOLD" is written on the button to inform you that you must press and hold the button for more than one second.

## Start-up

For detailed information refer to “Key Ignition Switch” in chapter 5.

### **NOTICE**

To prevent damaging the remote key:

- Keep the remote key away from water or any liquid and fire. If the inside of the remote key gets damp (due to drinks or moisture), or is heated, internal circuit may malfunction, excluding the car from the warranty.
- Avoid dropping or throwing the remote key.
- Protect the remote key from extreme temperatures.

## Mechanical key

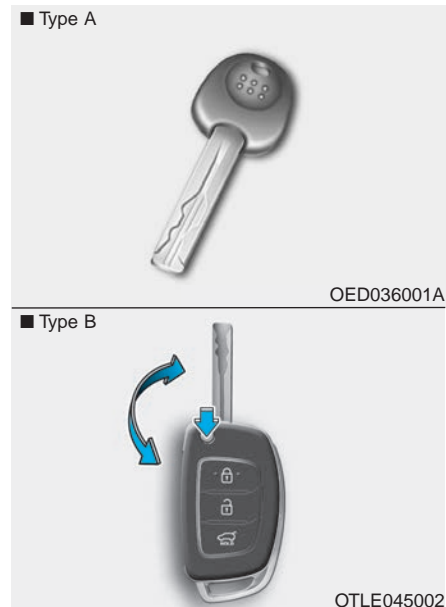

If the remote key does not operate normally, you can lock or unlock the door by using the mechanical key.



### Type B

To unfold the key, press the release button then the key will unfold automatically.

To fold the key, fold the key manually while pressing the release button.

#### **NOTICE**

**Do not fold the key without pressing the release button. This may damage the key.**

### ***Remote key precautions***

The remote key will not work if any of the following occur:

- The key is in the ignition switch.
- You exceed the operating distance limit (about 30 m [90 feet]).
- The remote key battery is weak.
- Other vehicles or objects may be blocking the signal.
- The weather is extremely cold.
- The remote key is close to a radio transmitter such as a radio station or an airport which can interfere with normal operation of the remote key.

When the remote key does not work correctly, open and close the door with the mechanical key. If you have a problem with the remote key, it is recommended that you contact an authorized HYUNDAI dealer.

If the remote key is in close proximity to your mobile phone, the signal could be blocked by your mobile phones normal operational signals. This is especially important when the phone is active such as making and receiving calls, text messaging, and/or sending/receiving emails. Avoid placing the remote key and your mobile phone in the same pants or jacket pocket and always try to maintain an adequate distance between the two devices.

### **i** Information

Changes or modifications not expressly approved by the party responsible for compliance could void the user's authority to operate the equipment. If the keyless entry system is inoperative due to changes or modifications not expressly approved by the party responsible for compliance, it will not be covered by your manufacturer's vehicle warranty.

#### **NOTICE**

Keep the remote key away from electromagnetic materials that blocks electromagnetic waves to the key surface.

### **Battery replacement**

If the remote key is not working properly, try replacing the battery with a new one.

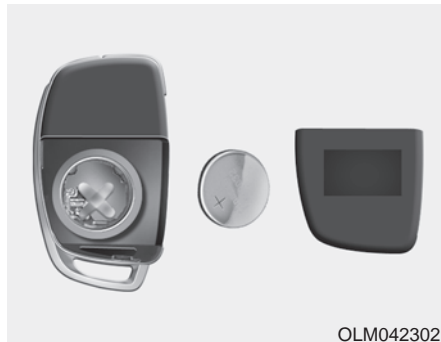

Battery Type: CR2032

To replace the battery:

1. Insert a slim tool into the slot and gently pry open the cover.
2. Remove the old battery and insert the new battery. Make sure the battery position is correct.
3. Reinstall the rear cover of the remote key.

If you suspect your remote key might have sustained some damage, or you feel your remote key is not working correctly, it is recommended that you contact an authorized HYUNDAI dealer.

### **i** Information



An inappropriately disposed battery can be harmful to the environment and human health. Dispose the battery according to your local law(s) and regulation.

### Smart key (if equipped)



Your HYUNDAI uses a Smart Key, which you can use to lock or unlock a door (and tailgate) and even start the engine.

1. Door Lock
2. Door Unlock

3. Tailgate Unlock
4. Remote start (if equipped)

### Locking

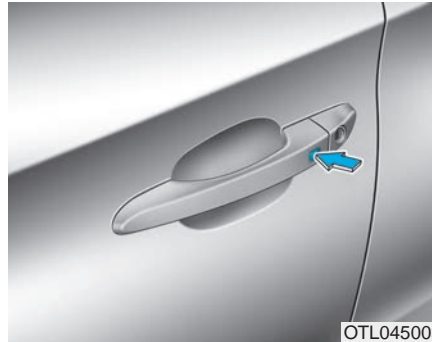

To lock :

1. Close all doors, engine hood and tailgate.
2. Either press the door handle button or press the Door Lock button (1) on the smart key.
3. The hazard warning lights will blink. Also, the outside rearview mirror will fold, if the outside rearview mirror folding switch is in the AUTO position (if equipped).

4. Make sure the doors are locked by checking the position of the door lock button inside the vehicle.

### **i** Information

The door handle button will only operate when the smart key is within 0.7~1 m (28~40 in.) from the outside door handle.

Even though you press the outside door handle button, the doors will not lock and the chime will sound for three seconds if any of the following occur:

- The Smart Key is in the vehicle.
- The Engine Start/Stop button is in ACC or ON position.
- Any door except the tailgate is open.

### WARNING

**Do not leave the Smart Key in your vehicle with unsupervised children. Unattended children could press the Engine Start/Stop button and may operate power windows or other controls, or even make the vehicle move, which could result in serious injury or death.**

## Unlocking

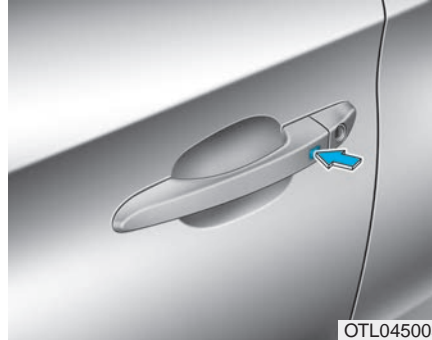

To unlock:

1. Carry the Smart Key.
2. Either press the door handle button or press the Door Unlock button (2) on the smart key.
3. The doors will unlock. The hazard warning lights will blink two times. Also, the outside rearview mirror will unfold, if the outside rearview mirror folding switch is in the AUTO position. (if equipped)

## Information

- The door handle button will only operate when the smart key is within 0.7~1 m (28~40 in.) from the outside door handle. Other people can also open the doors without the smart key in possession.
- After unlocking the doors, the doors will lock automatically after 30 seconds unless a door is opened.

### Tailgate unlocking

To unlock:

1. Carry the smart key.
2. Either press the tailgate handle button or press the Tailgate Unlock button (3) on the smart key for more than one second.
3. The hazard warning lights will blink two times. The tailgate will unlock. The power tailgate will unlock and then open (if equipped).

For more details, refer to “Power tailgate” in this chapter.

### **i** Information

After unlocking the tailgate, the tailgate will lock automatically after 30 seconds unless the tailgate is opened.

### Start-up

You can start the engine without inserting the key. **For detailed information refer to the Engine Start/Stop button in chapter 5.**

#### **NOTICE**

**To prevent damaging the smart key:**

- **Keep the smart key away from water or any liquid and fire. If the inside of the smart key gets damp (due to drinks or moisture), or is heated, internal circuit may malfunction, excluding the car from the warranty.**
- **Avoid dropping or throwing the smart key.**
- **Protect the smart key from extreme temperatures.**

#### **NOTICE**

**Always have the smart key with you when leaving the vehicle. If the smart key is left near the vehicle, the vehicle battery may be discharged.**

### Remote start (if equipped, for Middle East)



You can start the engine and turn on the climate system by pressing the remote start button (4) outside the vehicle.

To start and stop engine remotely :

1. Press the door lock button (1), and then the hazard warning lights blink once to alert you.

2. Press the Remote Start button (4) for more than 2 seconds to start the engine within 4 seconds after pressing the door lock button (1).
3. While remote starting, the hazard warning lights blink. If you want to stop the engine, press the Remote Start button (4) again.

The climate system will be continuously maintained, as selected when the engine is restarted. If the climate system is turned off before you have stopped the engine, the climate system does not operate when you start the engine remotely.

If someone without a designated smart key rides your vehicle while remote starting, the engine is automatically stopped for security matter.

### **i** Information

**After remotely starting the engine, the engine will turn off automatically after 10 minutes if you do not ride your vehicle matter.**

### **⚠ CAUTION**

- **The remote start will not work if you exceed the operating distance limit (about 10 m).**
- **Avoid idling the engine for prolonged periods to follow the emission regulations in your country.**
- **Laws in your country may restrict the use of remote start. You should check country regulations before using this remote starting system.**
- **It is only possible to start the engine remotely when shifted to P (Park).**
- **If the hood or the tailgate is opened, you cannot start the engine remotely.**

### **Mechanical key**

If the Smart Key does not operate normally, you can lock or unlock the door by using the mechanical key.

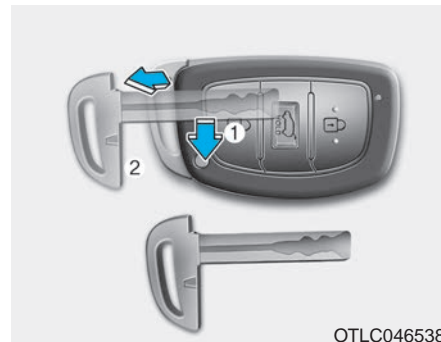

Press and hold the release button (1) and remove the mechanical key (2). Insert the mechanical key into the key hole on the door.

To reinstall the mechanical key, put the key into the hole and push it until a click sound is heard.

### Loss of a smart key

A maximum of two smart keys can be registered to a single vehicle. If you happen to lose your smart key, it is recommended that you should immediately take the vehicle and remaining key to your authorized HYUNDAI dealer or tow the vehicle, if necessary.

### Smart key precautions

The smart key will not work if any of the following occur:

- The smart key is close to a radio transmitter such as a radio station or an airport which can interfere with normal operation of the transmitter.
- The smart key is near a mobile two way radio system or a cellular phone.
- Another vehicle's smart key is being operated close to your vehicle.

When the smart key does not work correctly, open and close the door with the mechanical key. If you have a problem with the smart key, it is recommended that you contact an authorized HYUNDAI dealer.

If the smart key is in close proximity to your mobile phone, the signal could be blocked by your mobile phones normal operational signals. This is especially important when the phone is active such as making and receiving calls, text messaging, and/or sending/receiving emails. Avoid placing the smart key and your mobile phone in the same pants or jacket pocket and always try to maintain an adequate distance between the two devices.

### **i** Information

**Changes or modifications not expressly approved by the party responsible for compliance could void the user's authority to operate the equipment. If the keyless entry system is inoperative due to changes or modifications not expressly approved by the party responsible for compliance, it will not be covered by your manufacturer's vehicle warranty.**

### **NOTICE**

**Keep the smart key away from electromagnetic materials that blocks electromagnetic waves to the key surface.**

### Battery replacement



If the Smart Key is not working properly, try replacing the battery with a new one.

Battery Type: CR2032

To replace the battery:

1. Pry open the rear cover of the smart key.
2. Remove the old battery and insert the new battery. Make sure the battery position is correct.
3. Reinstall the rear cover of the smart key.

If you suspect your smart key might have sustained some damage, or you feel your smart key is not working correctly, it is recommended that you contact an authorized HYUNDAI dealer.

### **i** Information



**An inappropriately disposed battery can be harmful to the environment and human health. Dispose the battery according to your local law(s) and regulation.**

### **Immobilizer system (if equipped)**

The immobilizer system protects your vehicle from theft. If an improperly coded key (or other device) is used, the engine's fuel system is disabled.

When the ignition switch is placed in the ON position, the immobilizer system indicator should come on briefly, then go off. If the indicator starts to blink, the system does not recognize the coding of the key.

Place the ignition switch to the LOCK/OFF position, then place the ignition switch to the ON position again.

The system may not recognize your key's coding if another immobilizer key or other metal object (i.e., key chain) is near the key. The engine may not start because the metal may interrupt the transponder signal from transmitting normally.

If the system repeatedly does not recognize the coding of the key, it is recommended that you contact your HYUNDAI dealer.

Do not attempt to alter this system or add other devices to it. Electrical problems could result that may make your vehicle inoperable.

### **⚠ WARNING**

**In order to prevent theft of your vehicle, do not leave spare keys anywhere in your vehicle. Your immobilizer password is a customer unique password and should be kept confidential.**

### **NOTICE**

**The transponder in your key is an important part of the immobilizer system. It is designed to give years of trouble-free service, however you should avoid exposure to moisture, static electricity and rough handling. Immobilizer system malfunction could occur.**



## DOOR LOCKS

### Operating door locks from outside the vehicle

#### Mechanical key

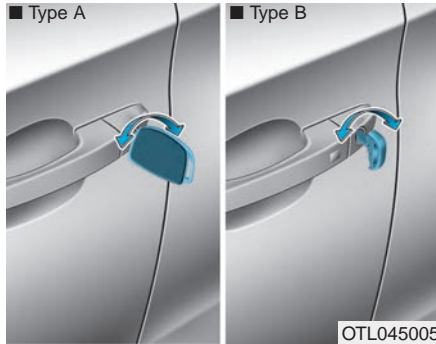

Turn the key toward the rear of the vehicle to unlock and toward the front of the vehicle to lock.

If you lock/unlock the driver's door with a key, all vehicle doors will lock/unlock automatically.

Once the doors are unlocked, they may be opened by pulling the door handle.

When closing the door, push the door by hand. Make sure that doors are closed securely.

#### Remote key



To lock the doors, press the Door Lock button (1) on the remote key.

To unlock the doors, press the Door Unlock button (2) on the remote key.

Once the doors are unlocked, they may be opened by pulling the door handle.

When closing the door, push the door by hand. Make sure that doors are closed securely.

#### **i** Information

- In cold and wet climates, door lock and door mechanisms may not work properly due to freezing conditions.
- If the door is locked/unlocked multiple times in rapid succession with either the vehicle key or door lock switch, the system may stop operating temporarily in order to protect the circuit and prevent damage to system components.

## Smart key

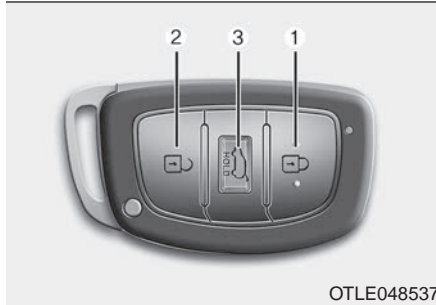
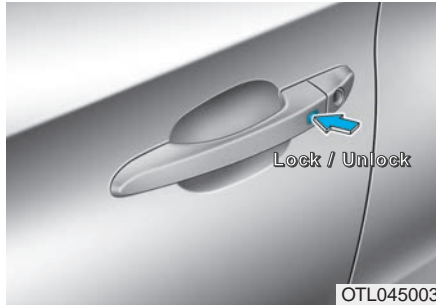

1. Door lock
2. Door unlock
3. Tailgate open

To lock the doors, press the button on the outside door handle while carrying the smart key with you or press the door lock button on the smart key.

To unlock the doors, press the button on the outside door handle while carrying the smart key with you or press the door unlock button on the smart key.

Once the doors are unlocked, they may be opened by pulling the door handle.

When closing the door, push the door by hand. Make sure that doors are closed securely.

## **i** Information

- In cold and wet climates, door lock and door mechanisms may not work properly due to freezing conditions.
- If the door is locked/unlocked multiple times in rapid succession with either the vehicle key or door lock switch, the system may stop operating temporarily in order to protect the circuit and prevent damage to system components.

### Operating door locks from inside the vehicle

#### With the door lock button



- To unlock a door, push the door lock button (1) to the “Unlock” position. The red mark (2) on the door lock button will be visible.
- To lock a door, push the door lock button (1) to the “Lock” position. If the door is locked properly, the red mark (2) on the door lock button will not be visible.
- To open a door, pull the door handle (3) outward.

- Front doors cannot be locked if the key is in the ignition switch and any front door is open.
- Doors cannot be locked if the smart key is in the vehicle and any door is open.

#### **i** Information

**If a power door lock ever fails to function while you are in the vehicle try one or more of the following techniques to exit:**

**Operate the door unlock feature repeatedly (both electronic and manual) while simultaneously pulling on the door handle.**

**Operate the other door locks and handles, front and rear.**

**Lower a front window and use the mechanical key to unlock the door from outside.**

#### **With the door handle**

##### Front door

If the inner door handle is pulled when the door is locked, the door will unlock and open.

##### Rear door

If the inner door handle is pulled once when the door is locked, the door will unlock.

If the inner door handle is pulled once more, the door will open.

### With the central door lock switch



When pressing the (🔒) portion (1) of the switch, all vehicle doors will lock.

- If any door is opened, the doors will not lock even though the lock button (1) of the central door lock switch is pressed.
- If the smart key is in the vehicle and any door is opened, the doors will not lock even though the lock button (1) of the central door lock switch is pressed.

When pressing the (🔓) portion (2) of the switch, all vehicle doors will unlock.

#### ⚠️ WARNING

- The doors should always be fully closed and locked while the vehicle is in motion. If the doors are unlocked, the risk of being thrown from the vehicle in a crash is increased.
- Do not pull the inner door handle of the driver's or passenger's door while the vehicle is moving.

#### ⚠️ WARNING

Do not leave children or animals unattended in your vehicle. An enclosed vehicle can become extremely hot, causing death or serious injury to unattended children or animals who cannot escape the vehicle. Children might operate features of the vehicle that could injure them, or they could encounter other harm, possibly from someone gaining entry to the vehicle.

#### ⚠️ WARNING

Leaving your vehicle unlocked increases the potential risk to you or others from someone hiding in your vehicle.

To secure your vehicle, while depressing the brake, move the shift lever to the P (Park) position (for automatic transaxle/dual clutch transmission) or first gear or R (Reverse, for manual transaxle), engage the parking brake, and place the ignition switch in the LOCK/OFF position, close all windows, lock all doors, and always take the key with you.

### WARNING

Opening a door when something is approaching may cause damage or injury. Be careful when opening doors and watch for vehicles, motorcycles, bicycles or pedestrians approaching the vehicle in the path of the door.

### WARNING

If you stay in the vehicle for a long time while the weather is very hot or cold, there are risks of injuries or danger to life. Do not lock the vehicle from the outside when someone is in the vehicle.

## Deadlocks (if equipped)

Some vehicles are equipped with a deadlock system. Deadlocks prevent opening of a door from either inside or outside the vehicle once the deadlocks have been activated providing an additional measure of vehicle security.

To lock the vehicle using the deadlock function, the doors must be locked by using the remote key or smart key. To unlock the vehicle, the transmitter or smart key must be used again.

### WARNING

Do not lock the doors with the remote key or the smart key with anybody left in the vehicle. The passenger in the vehicle cannot unlock the doors with the door lock button. For example, if the door is locked with the remote key, the passenger in the vehicle cannot unlock the door without the transmitter.

## Auto door lock/unlock features

### ***Impact sensing door unlock system (if equipped)***

All doors will be automatically unlocked when an impact causes the air bags to deploy.

### ***Speed sensing door lock system (if equipped)***

All doors will be automatically locked when vehicle speed exceeds 15 km/h (9 mph).

You can activate or deactivate the Auto Door Lock/Unlock features from the User Settings Mode on the LCD display. **For more details, refer to "LCD Display" in this chapter.**

## Child-protector rear door locks

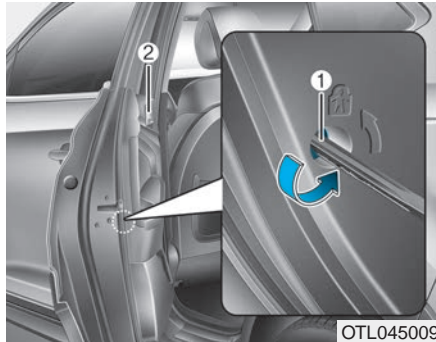

The child safety lock is provided to help prevent children seated in the rear from accidentally opening the rear doors. The rear door safety locks should be used whenever children are in the vehicle.

The child safety lock is located on the edge of each rear door. When the child safety lock is in the lock position (1), the rear door will not open if the inner door handle (2) is pulled.

To lock the child safety lock, insert a key (or screwdriver) into the hole and turn it to the lock position.

To allow a rear door to be opened from inside the vehicle, unlock the child safety lock.

### **WARNING**

**If children accidentally open the rear doors while the vehicle is in motion, they could fall out of the vehicle. The rear door safety locks should always be used whenever children are in the vehicle.**

### THEFT-ALARM SYSTEM (IF EQUIPPED)

This system helps to protect your vehicle and valuables. The horn will sound and the hazard warning lights will blink continuously if any of the following occurs:

- A door is opened without using the remote key or smart key.
- The tailgate is opened without using the remote key or smart key.
- The engine hood is opened.

The alarm continues for 30 seconds, then the system resets. To turn off the alarm, unlock the doors with the remote key or smart key.

The Theft Alarm System automatically sets 30 seconds after you lock the doors and the tailgate. For the system to activate, you must lock the doors and the tailgate from outside the vehicle with the remote key or smart key or by pressing the button on the outside of the door handles with the smart key in your possession.

The hazard warning lights will blink and the chime will sound once to indicate the system is armed.

Once the security system is set, opening any door, the tailgate, or the hood without using the remote key or smart key will cause the alarm to activate.

The Theft Alarm System will not set if the hood, the tailgate, or any door is not fully closed. If the system will not set, check the hood, the tailgate, or the doors are fully closed.

Do not attempt to alter this system or add other devices to it.

#### **i** Information

- **Do not lock the doors until all passengers have left the vehicle. If the remaining passenger leaves the vehicle when the system is armed, the alarm will be activated.**
- **If the vehicle is not disarmed with the remote key or smart key, open the doors by using the mechanical key and place the ignition switch in the ON position (for remote key) or start the engine (for smart key) and wait for 30 seconds.**
- **When the system is disarmed but a door or tailgate is not opened within 30 seconds, the system will be rearmed.**



### **i** Information

Vehicles equipped with a theft alarm system will have a label attached to the vehicle with the following words:

1. WARNING
2. SECURITY SYSTEM



## STEERING WHEEL

### Electric power steering (EPS)

The system assists you with steering the vehicle. If the engine is off or if the power steering system becomes inoperative, the vehicle may still be steered, but it will require increased steering effort.

Also, the steering effort becomes heavier as the vehicle's speed increases and becomes lighter as the vehicle's speed decreases for better control of the steering wheel.

Should you notice any change in the effort required to steer during normal vehicle operation, we recommend that the system be checked by an authorized HYUNDAI dealer.

#### NOTICE

**If the Electric Power Steering System does not operate normally, the warning light (⊖!) will illuminate on the instrument cluster. The steering wheel may become difficult to control or operate. We recommend to take your vehicle to an authorized HYUNDAI dealer and have the system checked as soon as possible.**

#### Information

The following symptoms may occur during normal vehicle operation:

- The steering effort may be high immediately after placing the ignition switch in the ON position.

This happens as the system performs the EPS system diagnostics. When the diagnostics is completed, the steering wheel will return to its normal condition.

(Continued)

(Continued)

- A click noise may be heard from the EPS relay after the ignition switch is placed to the ON or LOCK/OFF position.

A click noise may be heard from the EPS relay after the Engine Start/Stop button is in the ON or OFF position. (With Smart key system)

- Motor noise may be heard when the vehicle is at a stop or at a low driving speed.
- When you operate the steering wheel in low temperature, the steering effort may be high and abnormal noise may occur. If temperature rises, the noise will disappear. This is a normal condition.
- When the vehicle is stationary, if you turn the steering wheel all the way to the left or right continuously, the steering wheel effort increases. This is not a system malfunction. As time passes, the steering wheel effort will return to its normal condition.

## Tilt steering / Telescope steering

### WARNING

**Never adjust the steering wheel while driving. You may lose steering control and cause severe personal injury, death or accidents.**

### Information

After adjustment, sometimes the lock-release lever may not lock the steering wheel.

It is not a malfunction. This occurs when two gears are not engaged correctly. In this case, adjust the steering wheel again and then lock the steering wheel.

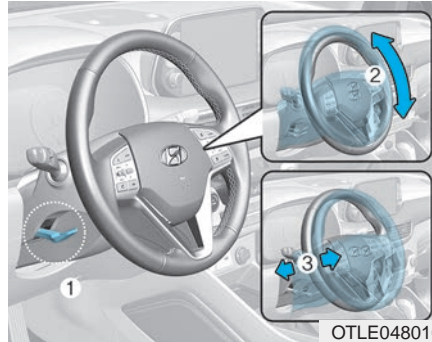

Pull down the lock-release lever (1) on the steering wheel column and adjust the steering wheel angle (2) and position (3). Move the steering wheel, so it points toward your chest, not toward your face. Make sure you can see the instrument cluster warning lights and gauges.

After adjusting, pull up the lock-release lever (1) to lock the steering wheel in place. Push the steering wheel both up and down to be certain it is locked in position. Always adjust the position of the steering wheel before driving.

### Heated steering wheel (if equipped)

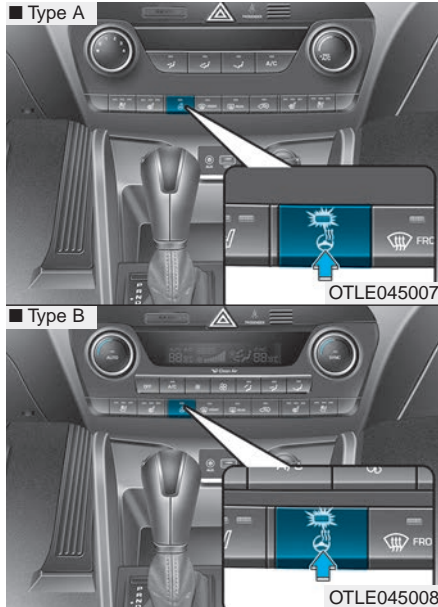

When the ignition switch is in the ON position or when the engine is running, press the heated steering wheel button to warm the steering wheel. The indicator on the button will illuminate.

To turn the heated steering wheel off, press the button again. The indicator on the button will turn off.

#### **i** Information

The heated steering wheel will turn off automatically approximately 30 minutes after the heated steering wheel is turned on.

#### **NOTICE**

**Do not install any cover or accessory on the steering wheel. This cover or accessory could cause damage to the heated steering wheel system.**

### Horn



To sound the horn, press the area indicated by the horn symbol on your steering wheel (see illustration). The horn will operate only when this area is pressed.

#### **NOTICE**

**Do not strike the horn severely to operate it, or hit it with your fist. Do not press on the horn with a sharp-pointed object.**

## MIRRORS

### Inside rearview mirror

Before you start driving, adjust the rearview mirror to the center on the view through the rear window.

#### **⚠ WARNING**

Make sure your line of sight is not obstructed. Do not place objects in the rear seat, cargo area, or behind the rear head-rests which could interfere with your vision through the rear window.

#### **⚠ WARNING**

To prevent serious injury during an accident or deployment of the air bag, do not modify the rearview mirror and do not install a wide mirror.

#### **⚠ WARNING**

**NEVER** adjust the mirror while driving. This may cause loss of vehicle control resulting in an accident.

#### **NOTICE**

When cleaning the mirror, use a paper towel or similar material dampened with glass cleaner. Do not spray glass cleaner directly on the mirror as that may cause the liquid cleaner to enter the mirror housing.

### Day/night rearview mirror (if equipped)

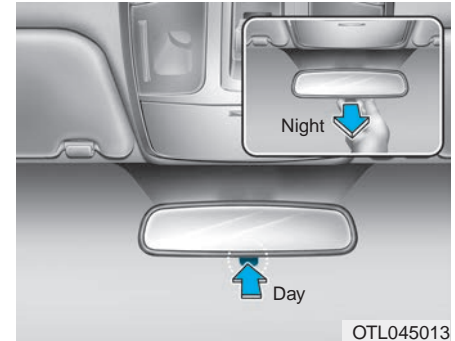

Make this adjustment before you start driving and while the day/night lever is in the day position.

Pull the day/night lever toward you to reduce glare from the headlights of the vehicles behind you during night driving.

*Remember that you lose some rearview clarity in the night position.*

### **Electric Chromic Mirror (ECM) (if equipped)**

The electric rearview mirror automatically controls the glare from the headlamp of the car behind you in nighttime or low light driving conditions.

When the engine is running, the glare is automatically controlled by the sensor mounted in the rearview mirror. The sensor detects the light level around the vehicle, and automatically adjusts to control the headlamp glare from vehicles behind you.

Whenever the shift lever is placed in R (Reverse), the mirror will automatically go to the brightest setting in order to improve the drivers view behind the vehicle.

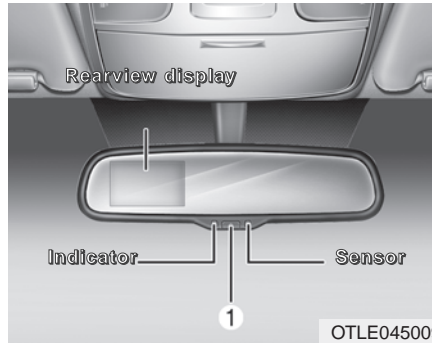

#### **To operate the electric rearview mirror:**

- Press the ON/OFF button (1) to turn the automatic dimming function off. The mirror indicator light will turn off.
- Press the ON/OFF button (1) to turn the automatic dimming function on. The mirror indicator light will illuminate.
- The mirror defaults to the ON position whenever the ignition switch or the Engine Start/Stop button is in the ON position.

### **Electric chromic mirror (ECM) with compass (if equipped)**

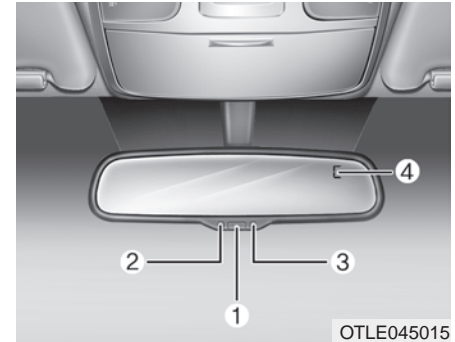

1. Feature Control Button
2. Status Indicator LED
3. Rear Light Sensor
4. Display Window

Automatic dimming rear view mirror automatically controls the glare of the headlights of the vehicle behind you when it is turned on by pressing and holding the button (1) for more than 3 but less than 6 seconds. It is turned off by pressing and holding the button (1) once more for more than 3 seconds but less than 6 seconds.

### 1. To operate Compass feature

Press and release the compass button, then the vehicle's directional heading will be displayed. Pressing and releasing the button again will turn off the display.

Heading display

- E : East
- W : West
- S : South
- N : North

ex) NE : North East

### 2. Calibration procedure

Press and hold the button for more than 6 but less than 9 seconds. When the compass memory is cleared a "C" will appear in the display.

- Driving the vehicle in a circle at less than 8 km/h 2 times or until the compass heading appears.
- Driving in a circle in right-handed direction and opposite direction are possible, and if the calibration is completed, the compass heading will appear.
- Keep driving in a circle until a compass heading appears.

### 3. Setting the compass zone

1. Find your current location and variance zone number on the zone map.

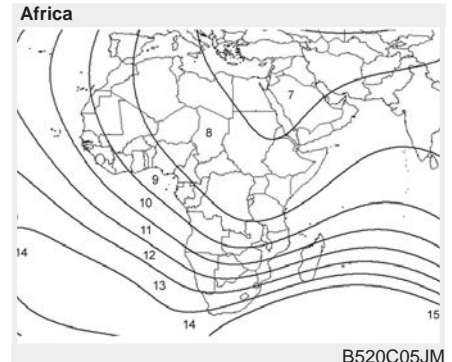
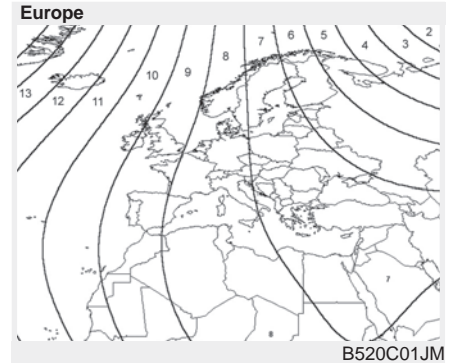

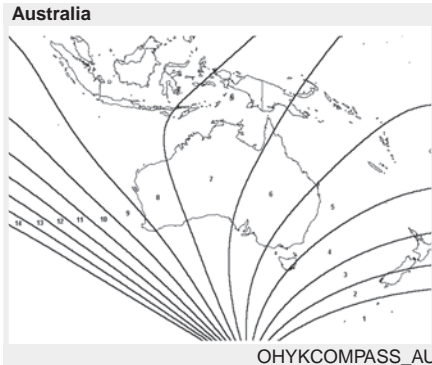
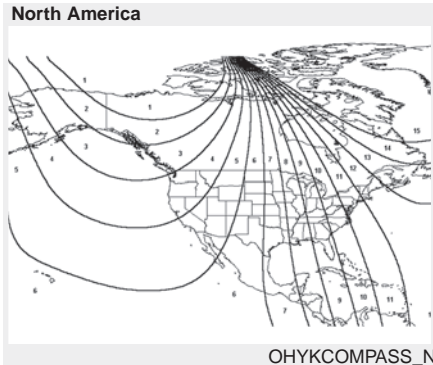
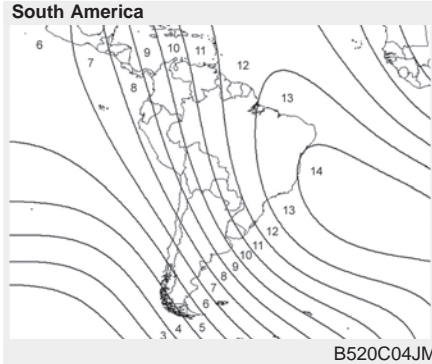
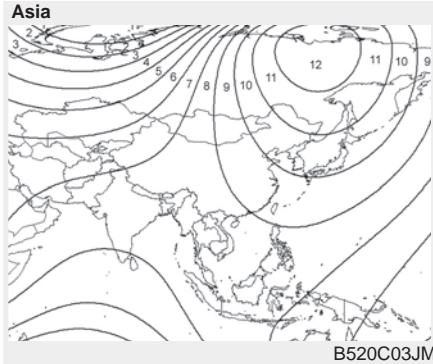

2. Press and hold the button for more than 3 but less than 6 seconds. The current zone number will appear in the display.
3. Press the button until the new zone number appears in the display. After you stop pressing the button in, the display will show a compass direction within a few seconds.

### CAUTION

1. Do not install the ski rack, antenna, etc. which are attached to the vehicle by means of a magnet. They affect the operation of the compass.
2. If the compass deviates from the correct indication soon after repeated adjustment, we recommend that you have the compass checked at an authorized HYUNDAI dealer.

(Continued)



(Continued)

3. The compass may not indicate the correct compass point in tunnels or while driving up or down a steep hill.

(The compass returns to the correct compass point when the vehicle moves to an area where the geomagnetism is stabilized.)

4. When cleaning the mirror, use a paper towel or similar material dampened with glass cleaner. Do not spray glass cleaner directly on the mirror as that may cause the liquid cleaner to enter the mirror housing.

## Outside rearview mirror

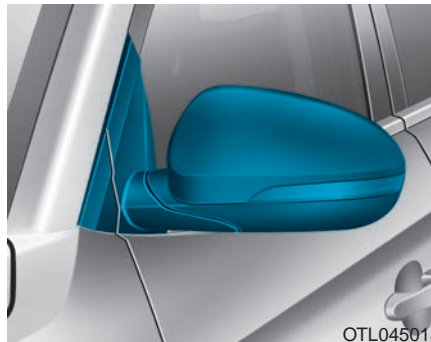

Be sure to adjust mirror angles before driving.

Your vehicle is equipped with both left-hand and right-hand outside rearview mirrors.

The mirror can be adjusted remotely with the remote switch.

The mirror heads can be folded to prevent damage during an automatic car wash or when passing through a narrow street.

### WARNING

- The right outside rearview mirror is convex. In some countries, the left outside rearview mirror is also convex. Objects seen in the mirror are closer than they appear.
- Use your interior rearview mirror or turn your head and look to determine the actual distance of following vehicles when changing lanes.

### WARNING

**Do not adjust or fold the outside rearview mirrors while driving. This may cause loss of vehicle control resulting in an accident.**



 **CAUTION**

- Do not scrape ice off the mirror face; this may damage the surface of the glass.
- If the mirror is jammed with ice, do not adjust the mirror by force. Use an approved spray de-icer (not radiator antifreeze) spray, or a sponge or soft cloth with very warm water, or move the vehicle to a warm place and allow the ice to melt.



Adjusting the rearview mirrors:

1. Press either the L (left side) or R (right side) button (1) to select the rearview mirror you would like to adjust.
2. Use the mirror adjustment control (2) to position the selected mirror up, down, left or right.
3. After adjustment, put the button into neutral (center) position to prevent inadvertent adjustment.

**NOTICE**

- The mirrors stop moving when they reach the maximum adjusting angles, but the motor continues to operate while the switch is pressed. Do not press the switch longer than necessary, the motor may be damaged.
- Do not attempt to adjust the outside rearview mirror by hand or the motor may be damaged.

## Folding the outside rearview mirror

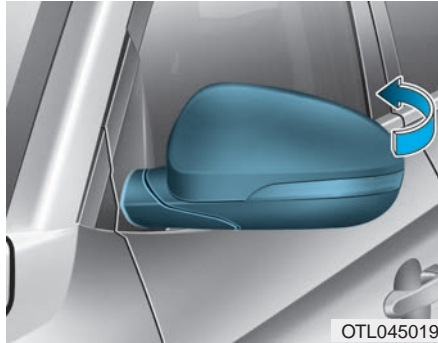

### Manual type

To fold the outside rearview mirror, grasp the housing of the mirror and then fold it toward the rear of the vehicle.



### Electric type (if equipped)

**Left** : The mirror will unfold.

**Right** : The mirror will fold.

### Center (AUTO) :

The mirror will fold or unfold automatically as follows:

- Without smart key system
  - The mirror will fold or unfold when the door is locked or unlocked by the remote key. (if equipped)
- With smart key system
  - The mirror will fold or unfold when the door is locked or unlocked by the smart key.

- The mirror will fold or unfold when the door is locked or unlocked by the button on the outside door handle.
- If "Convenience → Welcome mirror/ light" is selected in the User Settings mode on the LCD display, the mirror will unfold when you approach the vehicle (all doors closed and locked) with a smart key in possession. (if equipped)

### NOTICE

**The electric type outside rearview mirror operates even though the ignition switch is in the LOCK/OFF position. However, to prevent unnecessary battery discharge, do not adjust the mirrors longer than necessary while the engine is not running.**

### NOTICE

**Do not fold the electric type outside rearview mirror by hand. It could cause motor failure.**

## WINDOWS

### Power windows

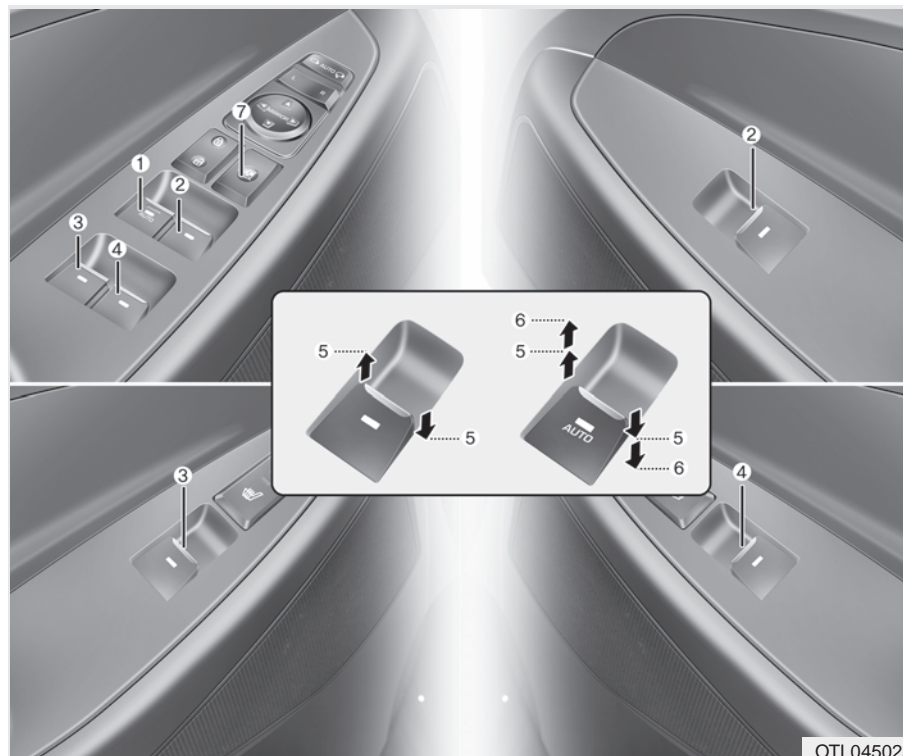

- (1) Driver's door power window switch
- (2) Front passenger's door power window switch
- (3) Rear door (left) power window switch
- (4) Rear door (right) power window switch
- (5) Window opening and closing
- (6) Automatic power window\*
- (7) Power window lock switch

\* : if equipped

The ignition switch must be in the ON position to be able to raise or lower the windows. Each door has a Power Window switch to control that door's window. The driver has a Power Window Lock switch which can block the operation of passenger windows. The power windows will operate for approximately 30 seconds after the ignition switch is placed in the ACC or OFF position. However, if the front doors are opened, the Power Windows cannot be operated even within the 30 second period.

### WARNING

**To avoid serious injury or death, do not extend your head, arms or body outside the windows while driving.**

### Information

- **In cold and wet climates, power windows may not work properly due to freezing conditions.**
- **While driving with the rear windows down or with the sunroof (if equipped) opened (or partially opened), your vehicle may demonstrate a wind buffeting or pulsation noise. This noise is normal and can be reduced or eliminated by taking the following actions. If the noise occurs with one or both of the rear windows down, partially lower both front windows approximately 2.5 cm (1 inch). If you experience the noise with the sunroof open, slightly close the sunroof.**

### Window opening and closing

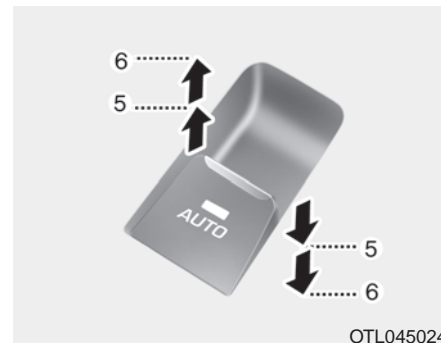

To open:

Press the window switch down to the first detent position (5). Release the switch when you want the window to stop.

To close:

Pull the window switch up to the first detent position (5). Release the window switch when you want the window to stop.

### ***Auto down window (if equipped)***

Pressing the power window switch momentarily to the second detent position (6) completely lowers the window even when the switch is released. To stop the window at the desired position while the window is in operation, pull up or press down and release the switch.

### ***Auto up/down window (if equipped)***

Pressing or pulling up the power window switch momentarily to the second detent position (6) completely lowers or lifts the window even when the switch is released. To stop the window at the desired position while the window is in operation, pull up or press down and release the switch.

### ***To reset the power windows***

If the power windows do not operate normally, the automatic power window system must be reset as follows:

1. Place the ignition switch to the ON position.
2. Close the window and continue pulling up on the power window switch for at least one second.

If the power windows do not operate properly after resetting, it is recommended that the system be checked by an authorized HYUNDAI dealer.

### **⚠ WARNING**

**The automatic reverse feature doesn't activate while resetting power window system. Make sure body parts or other objects are safely out of the way before closing the windows to avoid injuries or vehicle damage.**

### ***Automatic reverse (if equipped)***

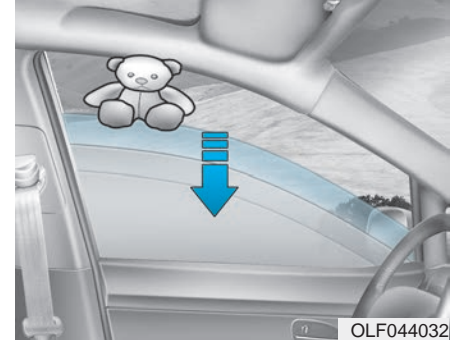

If a window senses any obstacle while it is closing automatically, it will stop and lower approximately 30 cm (12 inches) to allow the object to be cleared.

If the window detects the resistance while the power window switch is pulled up continuously, the window will stop upward movement then lower approximately 2.5 cm (1 inch).

If the power window switch is pulled up continuously again within 5 seconds after the window is lowered by the automatic window reverse feature, the automatic window reverse will not operate.

## **i** Information

The automatic reverse feature is only active when the “Auto Up” feature is used by fully pulling up the switch to the second detent.

### **⚠ WARNING**

Make sure body parts or other objects are safely out of the way before closing the windows to avoid injuries or vehicle damage. Objects less than 4 mm (0.16 inch) in diameter caught between the window glass and the upper window channel may not be detected by the automatic reverse window and the window will not stop and reverse direction.

### **NOTICE**

Do not install any accessories on the windows. The automatic reverse feature may not operate.

## **Power window lock switch**



The driver can disable the power window switches on the rear passengers' doors by pressing the power window lock switch.

When the power window lock switch is pressed:

- The driver's master control can operate all the power windows.
- The front passenger's control can operate the front passenger's power window.
- The rear passenger's control cannot operate the rear passengers' power window.

### **⚠ WARNING**

**Do not allow children to play with the power windows. Keep the driver's door power window lock switch in the LOCK position. Serious injury or death can result from unintentional window operation by a child.**

### **NOTICE**

- To prevent possible damage to the power window system, do not open or close two windows or more at the same time. This will also ensure the longevity of the fuse.
- Never try to operate the main switch on the driver's door and the individual door window switch in opposite directions at the same time. If this is done, the window will stop and cannot be opened or closed.

### **⚠ WARNING**

- **NEVER** leave the keys in your vehicle with unsupervised children, when the engine is running.
- **NEVER** leave any child unattended in the vehicle. Even very young children may inadvertently cause the vehicle to move, entangle themselves in the windows, or otherwise injure themselves or others.
- Always double check to make sure all arms, hands, head and other obstructions are safely out of the way before closing a window.

(Continued)

(Continued)

- Do not allow children to play with the power windows. Keep the driver's door power window lock switch in the LOCK position (pressed). Serious injury can result from unintentional window operation by the child.
- Do not extend your head, arms or body outside the windows while driving.

## ΠΑΝΟΡΑΜΑ SUNROOF (IF EQUIPPED)



If your vehicle is equipped with a sunroof, you can slide or tilt your sunroof with the sunroof control lever located on the overhead console.

The ignition switch must be in the ON position before you can open or close the sunroof.

The sunroof can be operated for approximately 30 seconds after the ignition key is removed or turned to the ACC or LOCK (or OFF) position. However, if the front door is opened, the sunroof cannot be operated even within 30 seconds.

### **i** Information

- In cold and wet climates, the sunroof may not work properly due to freezing conditions.
- After the vehicle is washed or in a rainstorm, be sure to wipe off any water that is on the sunroof before operating it.

### **⚠** WARNING

- **Never adjust the sunroof or sunshade while driving. This could result in loss of control and an accident that may cause death, serious injury, or property damage.**
- **Make sure heads, other body parts or objects are out of the way before using the sunroof.**
- **Do not extend your head, arms or body outside the sunroof while driving, to avoid serious injury.**
- **Do not leave the engine running and the key in your vehicle with unsupervised children.**

(Continued)

### (Continued)

- **Unattended children could operate the sunroof, which could result in serious injury.**
- **The panorama sunroof is made of glass, subject to break in case of accident. Passengers without the appropriate protection (e.g. seat belt, CRS, etc.) on may project out through the broken glasses and get seriously injured or even result in death.**
- **Do not sit on the top of the vehicle. It may cause injuries or vehicle damage.**

### **NOTICE**

- **Do not continue to move the sunroof control lever after the sunroof is fully opened, closed, or tilted. Damage to the motor or system components could occur.**
- **Make sure the sunroof is closed fully when leaving your vehicle. If the sunroof is open, rain or snow may leak through the sunroof and wet the interior as well as allow theft.**



### Sunshade



- To open the sunshade, pull the sunroof control lever backward (1) to the first detent position.
- To close the sunshade when the sunroof glass is closed, push the sunroof control lever forward (2).

To stop the sliding at any point, pull or push the sunroof control lever momentarily.

### Sliding the sunroof

**When the sunshade is closed**

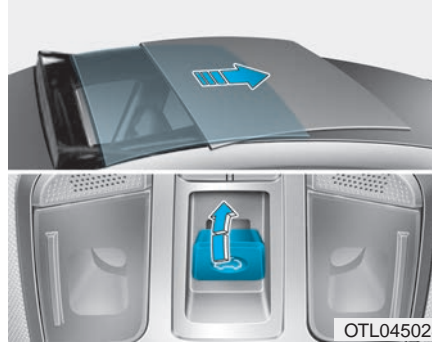

If you pull the sunroof control lever backward to the second detent, the sunshade will slide all the way open then the sunroof glass will slide all the way open. To stop the sunroof movement at any point, pull or push the sunroof control lever momentarily.

**When the sunshade is opened**

If you pull the sunroof control lever backward, the sunroof glass will slide all the way open. To stop the sunroof movement at any point, pull or push the sunroof control lever momentarily.

### **i** Information

**Only the front glass of the panorama sunroof opens and closes.**

## Tilting the sunroof

**When the sunshade is closed**



If you push the sunroof control lever upward, the sunshade will slide open then the sunroof glass will tilt.

To stop the sunroof movement at any point, pull or push the sunroof control lever momentarily.

## **When the sunshade is opened**

If you push the sunroof control lever upward, the sunroof glass will tilt.

To stop the sunroof movement at any point, pull or push the sunroof control lever momentarily.

## Closing the sunroof

**To close the sunroof glass only**



Push the sunroof control lever forward to the first detent position or pull the lever downward.

## **To close the sunroof glass with the sunshade**

Push the sunroof control lever forward to the second detent position. The sunroof glass will close then the sunshade will close automatically.

To stop the sunroof movement at any point, pull or push the sunroof control lever momentarily.

### Automatic reverse

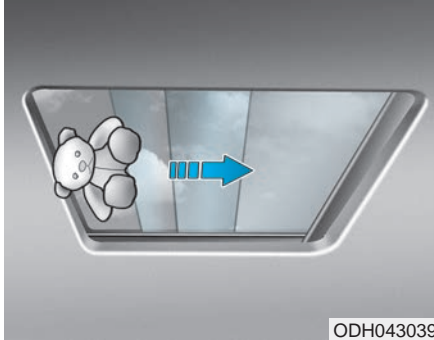

If an object or part of the body is detected while the sunroof glass or sunshade is closing automatically, it will reverse the direction, and then stop.

The auto reverse function does not work if a tiny obstacle is between the sliding glass or sunshade and the sunroof sash. You should always check that all passengers and objects are away from the sunroof before closing it.

### WARNING

Small objects that can get caught between the sunroof glass and the front glass channel may not be detected by the automatic reverse system. In this case, the sunroof glass will not detect the object and will not reverse direction.

### NOTICE

- Periodically remove any dirt that may accumulate on the sunroof guide rail or between the sunroof and roof panel, which can make a noise.
- Do not try to open the sunroof when the temperature is below freezing or when the sunroof is covered with snow or ice, otherwise the motor could be damaged. In cold and wet climates, the sunroof may not work properly.

## Resetting the sunroof



Sunroof needs to be reset if (in the followings)

- Battery is discharged or disconnected or the related fuse has been replaced or disconnected
- The one-touch sliding function of the sunroof does not normally operate

1. Turn the engine on and close the sunroof glass and sunshade completely.
2. Release the control lever.

3. Push the sunroof control lever forward in the direction of close (about 10 seconds) until the sunroof slightly moves. Then, release the lever.
4. Push the sunroof control lever forward in the direction of close until the sunroof operates as follows:

Sunshade Open → Glass Tilt Open  
→ Glass Slide Open → Glass Slide Close → Sunshade Close

Then, release the control lever.

When this is complete, the sunroof system is reset.

### **i** Information

- **If the sunroof does not reset when the vehicle battery is disconnected or discharged, or related fuse is blown, the sunroof may not operate normally.**
- **For more detailed information, we recommend that you contact an authorized HYUNDAI dealer.**

## Sunroof open warning (if equipped)



- If the driver turns off the engine when the sunroof is not fully closed, the warning chime will sound for approximately 3 seconds and sunroof open warning will appear on the LCD display.
- If the driver turns off the engine and opens the door when the sunroof is not fully closed, the open sunroof warning will appear on the LCD display until the door is closed or the sunroof is fully closed.

Close the sunroof securely when leaving your vehicle.

## EXTERIOR FEATURES

### Hood

#### Opening the hood

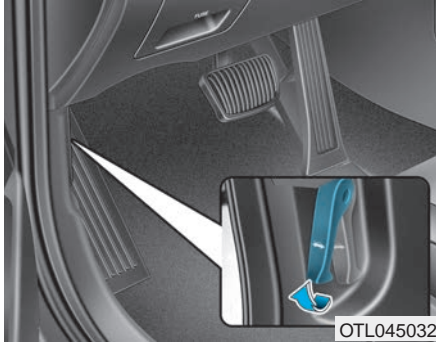

1. Park the vehicle and set the parking brake.
2. Pull the release lever to unlatch the hood. The hood should pop open slightly.

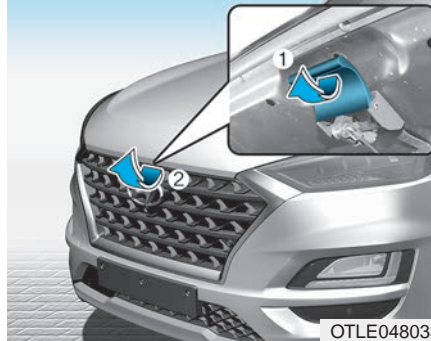

3. Go to the front of the vehicle, raise the hood slightly, push up the secondary latch (1) inside of the hood center and lift the hood (2).

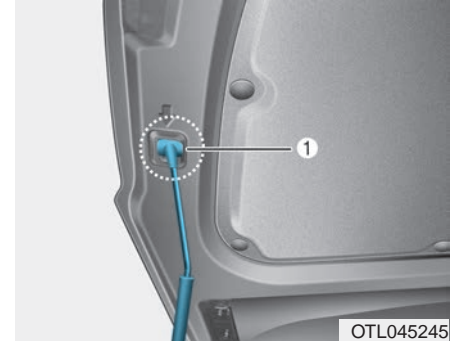

4. Pull out the stay rod.
5. Hold the hood opened with the stay rod (1).

#### **⚠ WARNING**

- Grasp the stay rod in the area wrapped in rubber. The rubber will help prevent you from being burned by hot metal when the engine is hot.
- The stay rod must be inserted completely into the hole provided whenever you inspect the engine compartment. This will prevent the hood from falling and possibly injuring you.

## ***Closing the hood***

1. Before closing the hood, check the following:
  - All filler caps in engine compartment must be correctly installed.
  - Gloves, rags or any other combustible material must be removed from the engine compartment.
2. Return the stay rod to its clip to prevent it from rattling.
3. Lower the hood halfway (lifted approximately 30 cm from the closed position) and push down to securely lock in place. Then double check to be sure the hood is secure.

### **⚠ WARNING**

**Always double check to be sure that the hood is firmly latched before driving away. Check there is no hood open warning light or message displayed on the instrument cluster. If the hood is not latched while the vehicle is moving, the chime will sound to warn the driver the hood is not fully latched. Driving with the hood opened may cause a total loss of visibility, which might result in an accident.**

### **⚠ WARNING**

- Before closing the hood, ensure that all obstructions are removed from the hood opening. Closing the hood with an obstruction present in the hood opening may result in property damage or severe personal injury.
- Do not leave gloves, rags or any other combustible material in the engine compartment. Doing so may cause a heat-induced fire.
- Do not move the vehicle with the hood raised. The view will be blocked and the hood could fall or be damaged.

### Fuel filler door

#### Opening the fuel filler door



1. Unlock all doors after turning off the engine. To open the fuel filler door, press the center edge of the fuel filler door.

#### **i** Information

The fuel filler door will open and close only when all doors are unlocked.

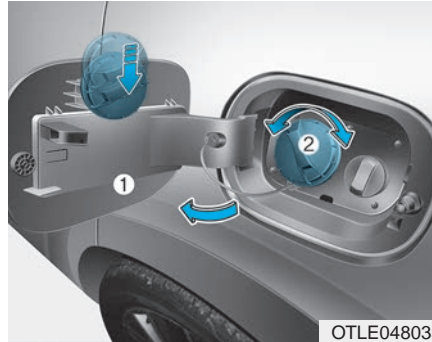

2. Pull the fuel filler door (1) out to fully open.
3. To remove the fuel tank cap (2), turn it counterclockwise. You may hear a hissing noise as the pressure inside the tank equalizes.
4. Place the cap on the fuel filler door.

#### **i** Information

If the fuel filler door does not open because ice has formed around it, tap lightly or push on the door to break the ice and release the door. Do not pry on the door. If necessary, spray around the door with an approved de-icer fluid (do not use radiator anti-freeze) or move the vehicle to a warm place and allow the ice to melt.

### ***Closing the fuel filler door***

1. To install the fuel tank cap, turn it clockwise until it “clicks” one time.
2. To close the fuel filler door, press the edge of the fuel filler door. Make sure it is securely closed.

#### **⚠ WARNING**

**Gasoline is highly flammable and explosive. Failure to follow these guidelines may result in SERIOUS INJURY or DEATH:**

- Read and follow all warnings posted at the gas station.
- Before refueling, note the location of the Emergency Gasoline Shut-Off, if available, at the gas station.
- Before touching the fuel nozzle, you should eliminate the potential build-up of static electricity by touching a metal part of the vehicle, a safe distance away from the fuel filler neck, nozzle, or other gas source, with your bare hand.

**(Continued)**

**(Continued)**

- **Do not use cellular phones while refueling. Electric current and/or electronic interference from cellular phones can potentially ignite fuel vapors and cause a fire.**
- **Do not get back into a vehicle once you have begun refueling. You can generate a build-up of static electricity by touching, rubbing or sliding against any item or fabric capable of producing static electricity. Static electricity discharge can ignite fuel vapors causing a fire. If you must re-enter the vehicle, you should once again eliminate potentially dangerous static electricity discharge by touching a metal part of the vehicle, away from the fuel filler neck, nozzle or other gasoline source, with your bare hand.**

**(Continued)**

**(Continued)**

- **When refueling, always move the shift lever to the P (Park) position (for automatic transaxle/dual clutch transmission) or first gear or R (Reverse, for manual transaxle), set the parking brake, and place the ignition switch to the LOCK/OFF position. Sparks produced by electrical components related to the engine can ignite fuel vapors causing a fire.**
- **When using an approved portable fuel container, be sure to place the container on the ground prior to refueling. Static electricity discharge from the container can ignite fuel vapors causing a fire. Once refueling has begun, contact between your bare hand and the vehicle should be maintained until the filling is complete.**

**(Continued)**



(Continued)

- Use only approved portable plastic fuel containers designed to carry and store gasoline.
- Do not use matches or a lighter and do not smoke or leave a lit cigarette in your vehicle while at a gas station, especially during refueling.
- Do not over-fill or top-off your vehicle tank, which can cause gasoline spillage.
- If a fire breaks out during refueling, leave the vicinity of the vehicle, and immediately contact the manager of the gas station and then contact the local fire department. Follow any safety instructions they provide.

(Continued)

(Continued)

- If pressurized fuel sprays out, it can cover your clothes or skin and thus subject you to the risk of fire and burns. Always remove the fuel cap carefully and slowly. If the cap is venting fuel or if you hear a hissing sound, wait until the condition stops before completely removing the cap.
- Always check that the fuel cap is installed securely to prevent fuel spillage in the event of an accident.

### **i** Information

Make sure to refuel your vehicle according to the "Fuel Requirements" suggested in the Introduction chapter.

#### **NOTICE**

- Do not spill fuel on the exterior surfaces of the vehicle. Any type of fuel spilled on painted surfaces may damage the paint.
- If the fuel filler cap requires replacement, use only a genuine HYUNDAI cap or the equivalent specified for your vehicle. An incorrect fuel filler cap can result in a serious malfunction of the fuel system or emission control system.

## TAILGATE

### Non-power tailgate (if equipped)

#### Opening the tailgate

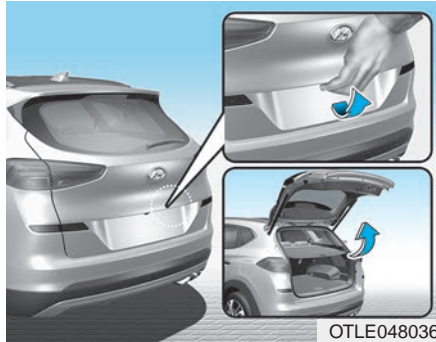

- The tailgate is locked or unlocked when all doors are locked or unlocked with the key, transmitter, smart key or central door lock/unlock switch.
- Only the tailgate is unlocked if the tailgate unlock button on the remote key or smart key is pressed for approximately 1 second.
- If unlocked, the tailgate can be opened by pressing the handle and pulling it up.

- Once the tailgate is opened and then closed, the tailgate locks automatically. (All doors must be locked.)

#### **i** Information

In cold and wet climates, door lock and door mechanisms may not work properly due to freezing conditions.

#### **⚠** WARNING

The tailgate swings upward. Make sure no objects or people are near the rear of the vehicle when opening the tailgate.

#### **⚠** CAUTION

Make certain that you close the tailgate before driving your vehicle. Possible damage may occur to the tailgate lift cylinders and attaching hardware if the tailgate is not closed prior to driving.

## Closing the tailgate



Lower and push down the tailgate firmly. Make sure that the tailgate is securely latched.

### **⚠ WARNING**

Make sure your hands, feet and other parts of your body are safely out of the way before closing the tailgate.

In case of any malfunction we recommend to visit authorized HYUNDAI dealer for inspection.

### **⚠ CAUTION**

Make sure nothing is near the tailgate latch and striker while closing the tailgate. It may damage the tailgate's latch.

### **⚠ WARNING**

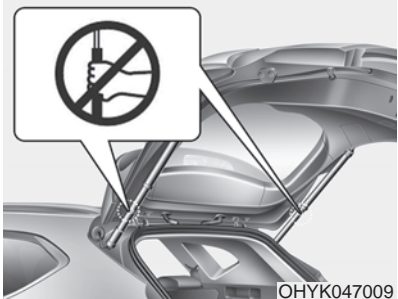

Do not hold the part (gas lifter) that supports the tailgate. Be aware that the deformation of the part may cause vehicle damage and a risk of safety accident.

### **⚠ WARNING**

Always keep the tailgate completely closed while the vehicle is in motion. If it is left open or ajar, poisonous exhaust gases containing carbon monoxide (CO) may enter the vehicle and serious illness or death may result.

Do not lean on tailgate lift cylinders, nor tie any rope or twine to them to avoid bending and consequent malfunction, vehicle damage or injury in case bent lift cylinder breaks the rear glass.

### **⚠ WARNING**

Occupants should never ride in the rear cargo area where no restraints are available. To avoid injury in the event of an accident or sudden stops, occupants should always be properly restrained.

## Emergency tailgate safety release



Your vehicle is equipped with the emergency tailgate safety release lever located on the bottom of the tailgate. When someone is inadvertently locked in the luggage compartment. The tailgate can be opened by doing as follows:

1. Remove the cover.
2. Push the release lever to the right.
3. Push up the tailgate.

## ⚠ WARNING

- For emergencies, be fully aware of the location of the emergency tailgate safety release lever in the vehicle and how to open the tailgate if you are accidentally locked in the luggage compartment.
- No one should be allowed to occupy the luggage compartment of the vehicle at any time. The luggage compartment is a very dangerous location in the event of a crash.
- Use the release lever for emergencies only. Use with extreme caution, especially while the vehicle is in motion.

## Power tailgate (if equipped)

### Power tailgate button



The power tailgate operates when:

- The power tailgate button is pressed with the engine off.

If you want to operate with the tailgate unlock button on the smart key, you can only ignition switch is OFF position.

- The power tailgate button is pressed when the ignition switch is in the ON position with the shift lever in P (Park, for automatic transaxle/dual clutch transmission vehicle) or the shift lever in neutral (for manual transaxle vehicle).

To activate or de-activate the power tailgate, go to User Settings mode and select the Power Tailgate on the LCD display.

For more details, refer to “LCD Display” in this chapter.

### **⚠ WARNING**

Never leave children or animals unattended in your vehicle.

Children or animals might operate the power tailgate that could result in injury to themselves or others, or damage the vehicle.

### **⚠ WARNING**

Make sure there are no people or objects around the tailgate before operating the power tailgate. Wait until the tailgate is opened fully and stopped before loading or unloading cargo or passengers from the vehicle.

### **⚠ CAUTION**

Do not close or open the power tailgate manually. This may cause damage to the power tailgate. If it is necessary to close or open the power tailgate manually when the battery is discharged or disconnected, do not apply excessive force.

### **NOTICE**

For emergency stop while operating, press any one of the Power tailgate button, Power tailgate handle switch, Power tailgate inner switch or Tailgate unlock button on the smart key shortly.

When the tailgate is restarted in the emergency stop state, it may be different from the direction of operation before stopping.

### **Opening the tailgate**

The power tailgate will open automatically by doing one of the following:



- Press the tailgate unlock button on the smart key for approximately one second.



- Press the power tailgate button for approximately one second.



- Press the tailgate handle switch carrying the smart key with you.

### ***Closing the tailgate***

The power tailgate will close automatically by doing one of the following:



- Press the tailgate unlock button on the smart key for approximately one second when the tailgate is opened. The tailgate will close and lock automatically.



- Press the power tailgate button for approximately one second when the tailgate is opened. The tailgate will close and lock automatically.



- Press the power tailgate inner switch for approximately one second when the tailgate is opened. The tailgate will close and lock automatically.

### ***Power tailgate non-opening conditions***

The tailgate does not open when the vehicle is in motion.

#### **⚠ WARNING**

**The chime will sound if you drive with the tailgate opened. Stop your vehicle immediately at a safe place and check if your tailgate is opened.**

#### **⚠ CAUTION**

**Operating the power tailgate more than 5 times continuously could cause damages to the operating motor. In this case, the system enters into a thermal protection mode. In thermal protection mode, the power tailgate can not operate and the chime will sound for 3 times by any switch inputs. Leave your power tailgate system for rest about 1 minute and then operate.**

## **i** Information

- The power tailgate can be operated when the engine is not running. However the power tailgate operation consumes large amounts of vehicle electric power. To prevent the battery from being discharged, do not operate it excessively. (e.g.: more than approximately 10 times repeatedly.)
- To prevent the battery from being discharged, do not leave the power tailgate in the open position for a long time.
- Do not modify or repair any part of the power tailgate by yourself. We recommend that you contact an authorized HYUNDAI dealer.
- When jacking up the vehicle to change a tire or repair the vehicle, do not operate the power tailgate. This could cause the power tailgate to operate improperly.
- In cold and wet climates, the power tailgate may not work properly due to freezing conditions.

## **Automatic reversal**



During power opening and closing if the power tailgate is blocked by an object or part of the body, the power tailgate will detect the resistance.

- If the resistance is detected while opening the tailgate, it will stop and move in the opposite direction.
- If the resistance is detected while closing the tailgate, it will stop and move in the opposite direction.

However, if the resistance is weak such as from an object that is thin or soft, or the tailgate is near the latched position, the automatic stop and reversal may not detect the resistance.

If the automatic reversal feature operates continuously more than twice during opening or closing operation, the power tailgate may stop at that position. At this time, close the tailgate manually and operate the tailgate automatically again.



 **WARNING**

**Never intentionally place any object or part of your body in the path of the power tailgate to make sure the automatic reversal operates.**

 **CAUTION**

**Do not put heavy stuffs on the power tailgate before you operate the power tailgate.**

**Additional weight on tailgate could cause damages to the system.**

***How to reset the power tailgate***

If the battery has been discharged or disconnected, or if the related fuse has been replaced or disconnected, for the power tailgate to operate normally, reset the power tailgate as follow:

1. Automatic transaxle/Dual clutch transmission:  
Put the shift lever in P (Park).  
Manual transaxle:  
Put the shift lever in neutral.
2. While Pressing the power tailgate inner switch, press the tailgate handle switch for more than 3 seconds. (the chime will sound)
3. Close the tailgate manually.

If the power tailgate does not work properly after the above procedure, we recommend that the system be checked by an authorized HYUNDAI dealer.

 **Information**

**If the power tailgate does not operate normally, check again if the gear position is in right position.**

## Power tailgate opening height user setting



The driver may set the height of a fully opened tailgate by following the below instruction.

1. Position the tailgate manually to the height you prefer.
2. Press the power tailgate inner switch for more than 3 seconds.
3. Close the tailgate manually after hearing the buzzer sound.

The tailgate will open to the height the driver has set up.

## ⚠ WARNING

Always keep the tailgate completely closed while the vehicle is in motion. If it is left open or ajar, poisonous exhaust gases containing carbon monoxide (CO) may enter the vehicle and serious illness or death may result.

## ⚠ WARNING

Occupants should never ride in the rear cargo area where no restraints are available. To avoid injury in the event of an accident or sudden stops, occupants should always be properly restrained.

## Emergency tailgate safety release



Your vehicle is equipped with the emergency tailgate safety release lever located on the bottom of the tailgate. When someone is inadvertently locked in the luggage compartment, the tailgate can be opened by doing as follows:

1. Remove the cover.
2. Push the release lever to the right.
3. Push up the tailgate.

**⚠ WARNING**

- For emergencies, be fully aware of the location of the emergency tailgate safety release lever in the vehicle and how to open the tailgate if you are accidentally locked in the luggage compartment.
- No one should be allowed to occupy the luggage compartment of the vehicle at any time. The luggage compartment is a very dangerous location in the event of a crash.
- Use the release lever for emergencies only. Use with extreme caution, especially while the vehicle is in motion.

**Smart tailgate (if equipped)**



On the vehicle equipped with a smart key, the tailgate can be opened with no-touch activation using the Smart tailgate system.

**How to use the Smart Tailgate**

The tailgate can be opened with no-touch activation satisfying all the conditions below.

- After 15 seconds when all doors are closed and locked
- Positioned in the detecting area for more than 3 seconds.

**i Information**

- The Smart Tailgate does not operate when:
  - The smart key is detected within 15 seconds after the doors are closed and locked, and is continuously detected.
  - The smart key is detected within 15 seconds after the doors are closed and locked, and 1.5 m (60 in.) from the front door handles. (for vehicles equipped with Welcome Light)
  - A door is not locked or closed.
  - The smart key is in the vehicle.

## 1. Setting

To activate the Smart Tailgate, go to User Settings Mode and select Smart Tailgate on the LCD display.

✳ For more details, refer to "LCD Display" in this chapter.



## 2. Detect and Alert

If you are positioned in the detecting area (50 ~100 cm (20 ~ 40 in.) behind the vehicle) carrying a smart key, the hazard warning lights will blink and chime will sound to alert you the smart key has been detected and the tailgate will open.

### **i** Information

**Do not approach the detecting area if you do not want the tailgate to open. If you have unintentionally entered the detecting area and the hazard warning lights and chime starts to operate, leave the detecting area with the smart key. The tailgate will stay closed.**



## 3. Automatic opening

The hazard warning lights will blink and chime will sound 6 times and then the tailgate will slowly open.

**⚠ WARNING**

- Make certain that you close the tailgate before driving your vehicle.
- Make sure there are no people or objects around the tailgate before opening or closing the tailgate.
- Make sure objects in the rear cargo area do not come out when opening the tailgate on the slope way. It may cause serious injury.
- Make sure to deactivate the Smart tailgate function when washing your vehicle. Otherwise, the tailgate may open inadvertently.
- The key should be kept out of reach of children. Children may inadvertently open the Smart Tailgate while playing around the rear area of the vehicle.

**How to deactivate the Smart Tailgate function using the smart key**

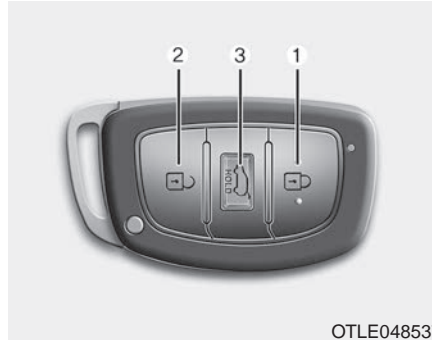

1. Door lock
2. Door unlock
3. Tailgate open

If you press any button of the smart key during the Detect and Alert stage, the Smart Tailgate function will be deactivated.

Make sure to be aware of how to deactivate the Smart Tailgate function for emergency situations.

**i Information**

- If you press the door unlock button (2), the Smart Tailgate function will be deactivated temporarily. But, if you do not open any door for 30 seconds, the Smart Tailgate function will be activated again.
- If you press the tailgate open button (3) for more than 1 second, the tailgate opens.
- If you press the door lock button (1) or tailgate open button (3) when the Smart Tailgate function is not in the Detect and Alert stage, the Smart Tailgate function will not be deactivated.
- In case you have deactivated the Smart Tailgate function by pressing the smart key button and opened a door, the Smart Tailgate function can be activated again by closing and locking all doors.

## Detecting area



- The Smart Tailgate operates with a welcome alert if the smart key is detected within 50 ~ 100 cm (20 ~ 40 in.) from the tailgate.
  - The alert stops at once if the smart key is positioned outside the detecting area during the Detect and Alert stage.
- i** Information
- The Smart Tailgate function will not work if any of the following occurs:
    - The smart key is close to a radio transmitter such as a radio station or an airport which can interfere with normal operation of the transmitter.
    - The smart key is near a mobile two way radio system or a cellular phone.
    - Another vehicle's smart key is being operated close to your vehicle.
  - The detecting range may decrease or increase when :
    - One side of the tire is raised to replace a tire or to inspect the vehicle.
    - The vehicle is slantingly parked on a slope or unpaved road, etc.

## INSTRUMENT CLUSTER

### ■ Type A

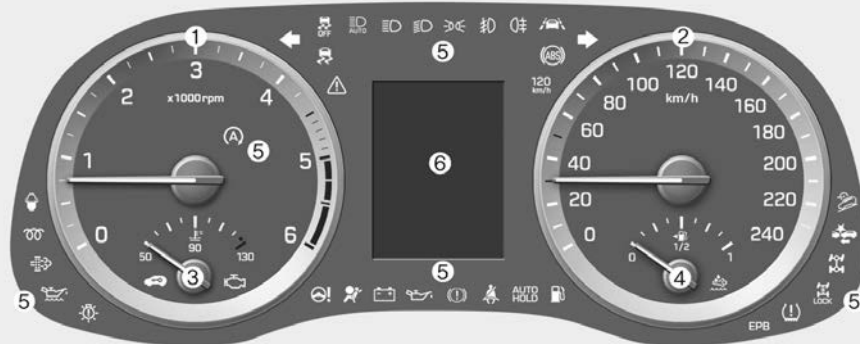

1. Tachometer
2. Speedometer
3. Engine coolant temperature gauge
4. Fuel gauge
5. Warning and indicator lights
6. LCD display (including Trip computer)

**The actual cluster in the vehicle may differ from the illustration.**  
For more details, refer to the "Gauges" in this chapter.

## ■ Type B

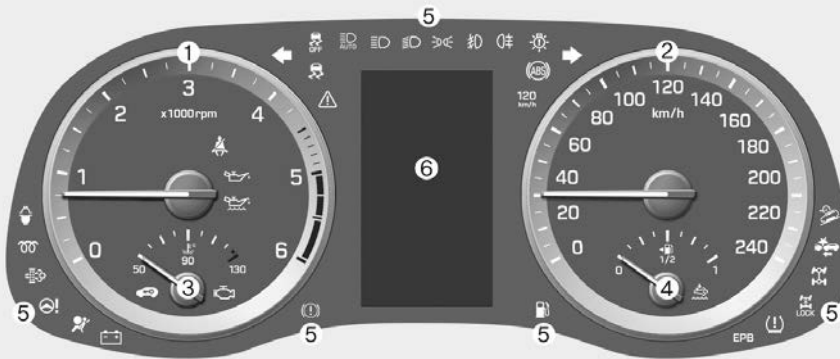

1. Tachometer
2. Speedometer
3. Engine coolant temperature gauge
4. Fuel gauge
5. Warning and indicator lights
6. LCD display (including Trip computer)

**The actual cluster in the vehicle may differ from the illustration.  
For more details, refer to the "Gauges" in this chapter.**

OTLE048640



## Instrument cluster control

### Instrument panel illumination

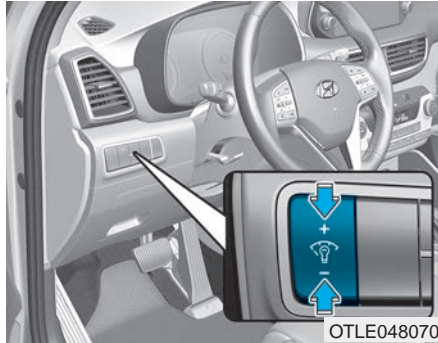

When the vehicle's parking lights or headlights are on, press the illumination control button to adjust the brightness of the instrument panel illumination.

When pressing the illumination control button, the interior switch illumination intensity is also adjusted.

## WARNING

**Never adjust the instrument cluster while driving. This could result in loss of control and lead to an accident that may cause death, serious injury, or property damage.**

- The brightness of the instrument panel illumination is displayed.
- If the brightness reaches to the maximum or minimum level, an alarm will sound.

## Gauges

### Speedometer

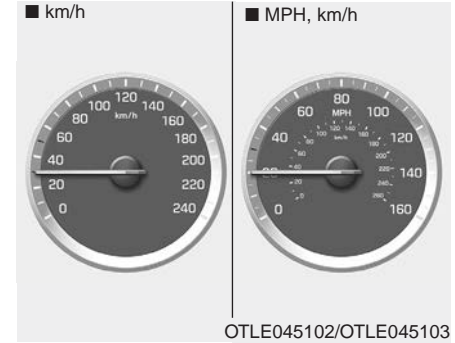

The speedometer indicates the speed of the vehicle and is calibrated in kilometers per hour (km/h) and/or miles per hour (MPH).

## Tachometer

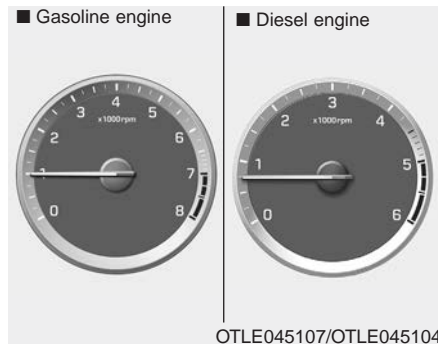

The tachometer indicates the approximate number of engine revolutions per minute (rpm).

Use the tachometer to select the correct shift points and to prevent lugging and/or over-revving the engine.

### NOTICE

Do not operate the engine within the tachometer's RED ZONE. This may cause severe engine damage.

## Engine Coolant Temperature gauge

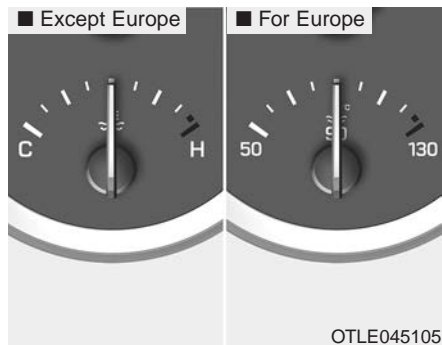

This gauge indicates the temperature of the engine coolant when the ignition switch is in the ON position.

### NOTICE

If the gauge pointer moves beyond the normal range area toward the "130 or H" position, it indicates overheating that may damage the engine.

Do not continue driving with an overheated engine. If your vehicle overheats, refer to "If the Engine Overheats" in chapter 6.

### ⚠ WARNING

Never remove the radiator cap when the engine is hot. The engine coolant is under pressure and could cause severe burns. Wait until the engine is cool before adding coolant to the reservoir.

### Fuel Gauge

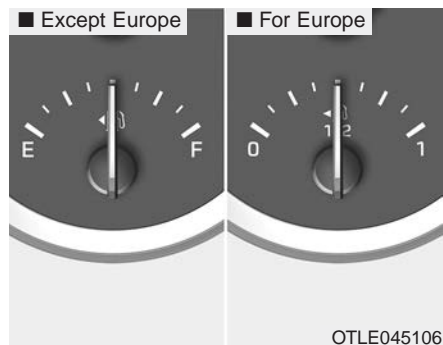

This gauge indicates the approximate amount of fuel remaining in the fuel tank.

#### **i** Information

- The fuel tank capacity is given in chapter 8.
- The fuel gauge is supplemented by a low fuel warning light, which will illuminate when the fuel tank is nearly empty.
- On inclines or curves, the fuel gauge pointer may fluctuate or the low fuel warning light may come on earlier than usual due to the movement of fuel in the tank.

### **!** WARNING

Running out of fuel can expose vehicle occupants to danger. You must stop and obtain additional fuel as soon as possible after the warning light comes on or when the gauge indicator comes close to the "0 or E (Empty)" level.

#### **NOTICE**

**Avoid driving with an extremely low fuel level. Running out of fuel could cause the engine to misfire damaging the catalytic converter.**

### Outside Temperature Gauge

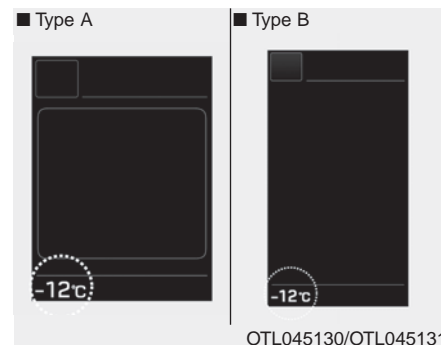

This gauge indicates the current outside air temperatures either in Celsius (°C) or Fahrenheit.

- Temperature range : -40°C ~ 60°C  
(-104°F ~ 140°F)

The outside temperature on the display may not immediately change like a general thermometer not to distract the driver.

The temperature unit (from °C to °F or from °F to °C) can be changed by:

- User Settings mode in the Cluster : You can change the temperature unit in the "Other Features - Temperature unit" .

- Automatic climate control system :  
While pressing the OFF button,  
press the AUTO button for 3 seconds  
or more.

The temperature unit of the instrument  
cluster and climate control system will  
change at once.

## Icy Road Warning Light (if equipped)

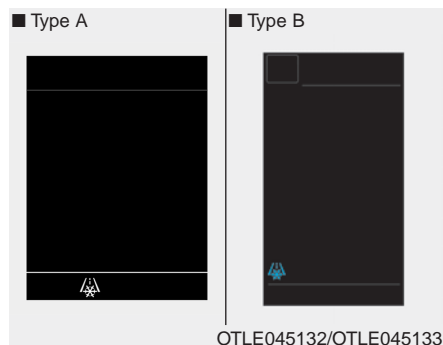

This warning light is to warn the driver  
the road may be icy.

When the temperature on the out-  
side temperature gauge is approxi-  
mately below 4°C (40°F), the Icy  
Road Warning Light and Outside  
Temperature Gauge blinks 10 times,  
and then illuminates. Also, the warn-  
ing chime sounds 3 times.

### **i** Information

If the icy road warning light appears  
while driving, you should drive more  
attentively and safely refraining from  
over-speeding, rapid acceleration, sud-  
den braking or sharp turning, etc.

## Transaxle Shift Indicator

### **Automatic Transaxle Shift Indicator (if equipped)**

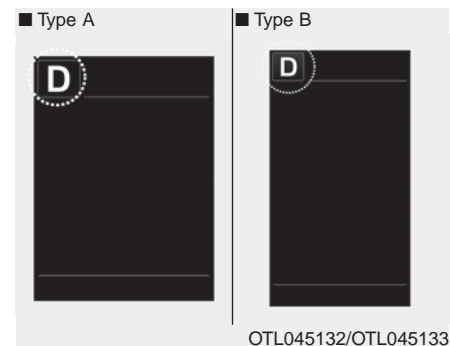

This indicator displays which automat-  
ic transaxle shift lever is selected.

- Park : P
- Reverse : R
- Neutral : N
- Drive : D
- Sports Mode :
  - 1,2,3,4,5,6  
(6 speed transmission)
  - 1,2,3,4,5,6,7,8  
(8 speed transmission)

### Dual Clutch Transmission Shift Indicator (if equipped)

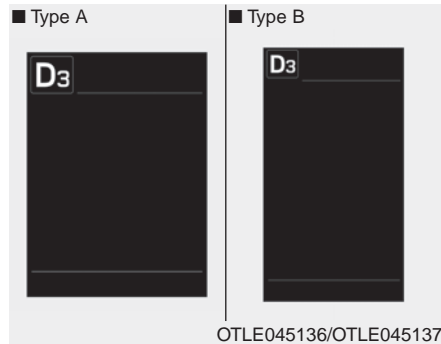

This indicator displays which shift lever is selected.

- Park : P
- Reverse : R
- Neutral : N
- Drive : D
- Sports Mode : D1, D2, D3, D4, D5, D6, D7

### Automatic Transaxle Shift Indicator / Dual Clutch Transmission Shift Indicator (for Europe, if equipped)

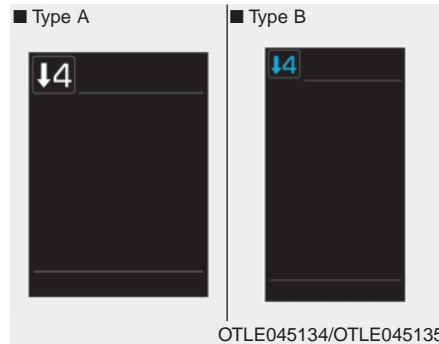

In the Sports Mode, this indicator informs which gear is desired while driving to save fuel.

- Automatic transmission shift indicator (8 speed transmission)
  - Shifting up : ▲2, ▲3, ▲4, ▲5, ▲6, ▲7, ▲8
  - Shifting down : ▼1, ▼2, ▼3, ▼4, ▼5, ▼6, ▼7

- Automatic transmission shift indicator (6 speed transmission)
  - Shifting up : ▲2, ▲3, ▲4, ▲5, ▲6
  - Shifting down : ▼1, ▼2, ▼3, ▼4, ▼5
- Dual clutch transmission shift indicator
  - Shifting up : ▲2, ▲3, ▲4, ▲5, ▲6, ▲7
  - Shifting down : ▼1, ▼2, ▼3, ▼4, ▼5, ▼6

For example

- ▲3 : Indicates that shifting up to the 3rd gear is desired (currently the shift lever is in the 2nd or 1st gear).
- ▼3 : Indicates that shifting down to the 3rd gear is desired (currently the shift lever is in the 4th, 5th, or 6th gear).

When the system is not working properly, the indicator is not displayed.

## Manual Transaxle Shift Indicator (if equipped)

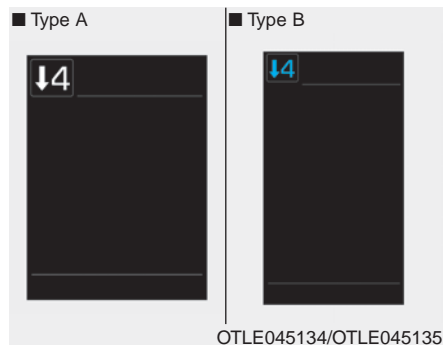

This indicator informs which gear is desired while driving to save fuel.

- Shifting up : ▲2, ▲3, ▲4, ▲5, ▲6
- Shifting down : ▼1, ▼2, ▼3, ▼4, ▼5

For example

- ▲3 : Indicates that shifting up to the 3rd gear is desired (currently the shift lever is in the 2nd or 1st gear).
- ▼3 : Indicates that shifting down to the 3rd gear is desired (currently the shift lever is in the 4th, 5th, or 6th gear).

When the system is not working properly, the indicator is not displayed.

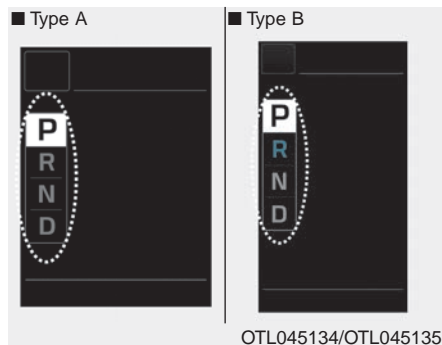

### Shift Indicator Pop-up (if equipped)

The pop-up that indicates the current gear position is displayed in the cluster for about 2 seconds when shifting into other positions (P/R/N/D).

## Odometer

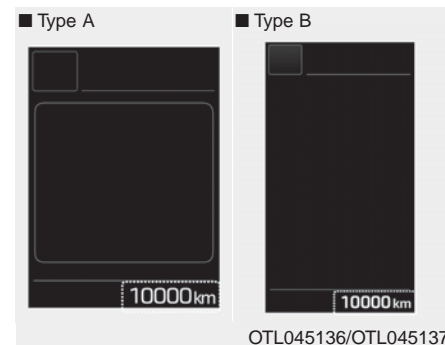

The odometer indicates the total distance that the vehicle has been driven and should be used to determine when periodic maintenance should be performed.

### Distance to empty

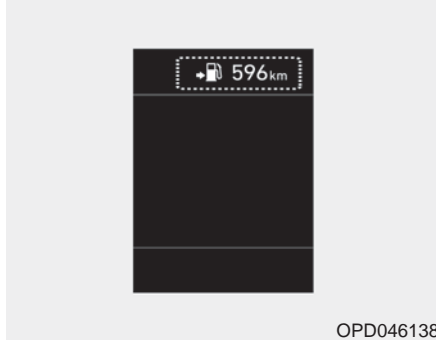

- The distance to empty is the estimated distance the vehicle can be driven with the remaining fuel.
- If the estimated distance is below 1 km (1 mi.), the trip computer will display “---” as distance to empty.

### **i** Information

- If the vehicle is not on level ground or the battery power has been interrupted, the distance to empty function may not operate correctly.
- The distance to empty may differ from the actual driving distance as it is an estimate of the available driving distance.
- The trip computer may not register additional fuel if less than 6 liters (1.6 gallons) of fuel are added to the vehicle.
- The distance to empty may vary significantly based on driving conditions, driving habits, and condition of the vehicle.

### LCD DISPLAY LCD display control

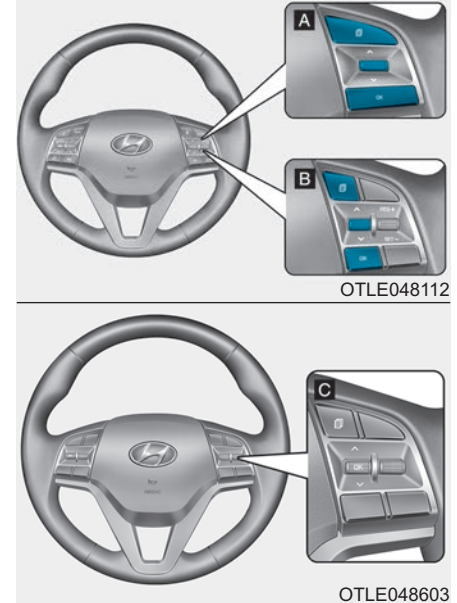





[A] : Type A, [B] : Type B, [C] : Type C

The LCD display modes can be changed by using the control buttons.

- (1)  : MODE button for changing modes
- (2) ▲, ▼ : MOVE switch for changing items
- (3) OK : SELECT/RESET button for setting or resetting the selected item

## LCD modes

Modes	Symbol	Explanation
Trip Computer		This mode displays driving information such as the tripmeter, fuel economy, etc. For more details, refer to "Trip Computer" in this chapter.
Turn By Turn (TBT)		This mode displays the state of the navigation.
Assist		This mode displays the state of : - Lane Keeping Assist (LKA) system - Driver Attention Warning (DAW) system - Tire pressure - Driving force distribution (4WD)  <b>For more details, refer to "Lane Keeping Assist (LKA) system", "Driver Attention Warning (DAW) system" in chapter 5 and "Tire Pressure Monitoring System (TPMS)" in chapter 6.</b>
User Settings		In this mode, you can change settings of the doors, lamps, etc.
Warning		This mode displays warning messages related to the Cruise system, etc.



### ***Shift to P to edit settings / Engage parking brake to edit settings***

This warning message illuminates if you try to select an item from the User Settings mode while driving.

- Automatic transaxle / dual clutch transmission

For your safety, change the User Settings after parking the vehicle, applying the parking brake and moving the shift lever to P (Park).

- Manual transaxle

For your safety, change the User Settings after engaging the parking brake.

### ***Quick guide (Help, if equipped)***

This mode provides quick guides for the systems in the User Settings mode.

Select an item, press and hold the OK button.

**For more details about each system, refer to this Owner's Manual.**

### ***Trip computer mode***

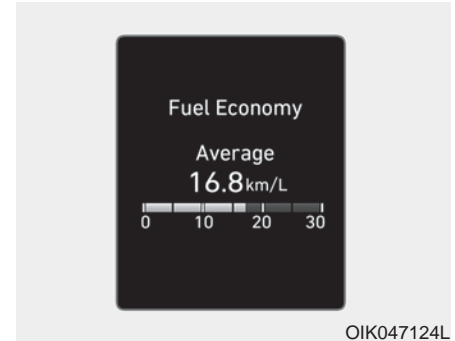

This mode displays driving information like the tripmeter, fuel economy, etc.

**For more details, refer to “Trip Computer” in this chapter.**

### Turn By Turn (TBT) mode (if equipped)

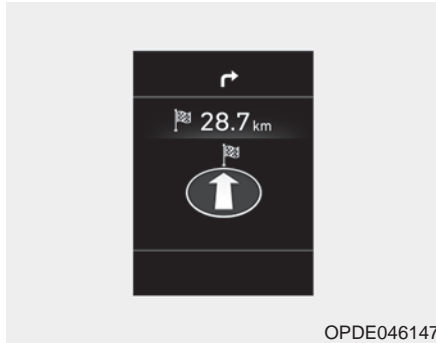

This mode displays the state of the navigation.

### Assist mode



#### SCC/LKA/DAW

This mode displays the state of the Smart Cruise Control (SCC), Lane Keeping Assist (LKA) and Driver Attention Warning (DAW).

**For more details, refer to each system information in chapter 5.**



#### Tire Pressure

This mode displays information related to Tire Pressure.

**For more details, refer to "Tire Pressure Monitoring System (TPMS)" in chapter 6.**



### **Driving force distribution (4WD)**

This mode displays information related to 4WD driving force.

If the vehicle is in 4WD lock state, this mode is not displayed.

**For detailed information, refer to the ‘Four Wheel Drive’ in the chapter 5.**

### **Warning message**

If one of followings occurs, warning messages will be displayed in the information mode for several seconds.

- Low washer fluid (if equipped)
- Exterior lamp malfunction (if equipped)
- Blind-Spot Collision Warning (BCW) system malfunction (if equipped)
- Tire Pressure Monitoring System (TPMS, if equipped)
- High Beam Assist (HBA) malfunction (if equipped)
- Forward Collision-Avoidance Assist (FCA) malfunction (if equipped)

### **User settings mode**

In this mode, you can change the settings of the instrument cluster, doors, lamps, etc.

1. Driver Assistance
2. Door
3. Lights
4. Sound
5. Convenience
6. Service interval
7. Other Features
8. Languages
9. Reset settings

**The information provided may differ depending on which functions are applicable to your vehicle.**

## 1. Driver Assistance

Items	Explanation
SCC response	<ul style="list-style-type: none"> <li>• Fast/Normal/Slow</li> </ul> To adjust the sensitivity of the Smart Cruise Control system. <b>For more details, refer to "Smart Cruise Control with Stop &amp; Go" in chapter 5.</b>
Speed Limit Warning	To activate or deactivate the Intelligent Speed Limit Warning system. <b>For more details, refer to the "Intelligent Speed Limit Warning (ISLW)" in chapter 5.</b>
DAW (Driver Attention Warning)	To adjust the sensitivity of the Driver Attention Warning (DAW). - High Sensitivity/Normal Sensitivity/Off <b>For more details, refer to the "Driver Attention Warning (DAW)" in chapter 5.</b>
Lane safety	To adjust the Lane Keeping Assist (LKA) function. - LKA (Lane Keeping Assist) - LDW (Lane Departure Warning) - Active LKA (if equipped) <b>For more details, refer to the "Lane Keeping Assist (LKA) system" in chapter 5.</b>
FCA (Forward Collision-Avoidance Assist)	To activate or deactivate the Forward Collision-Avoidance Assist (FCA) system. <b>For more details, refer to the "Forward Collision-Avoidance Assist (FCA) system" in chapter 5.</b>
FCW (Forward Collision Warning)	To adjust the warning timing of the Forward Collision Warning (FCW) system. - Early / Normal / Late <b>For more details, refer to the "Forward Collision-Avoidance Assist (FCA) system" in chapter 5.</b>
RCCW (Rear Cross-Traffic Collision Warning)	To activate or deactivate the Rear Cross-Traffic Collision Warning (RCCW) system. <b>For more details, refer to the "Blind-spot Collision Warning (BCW) system" in chapter 5.</b>
BCW sound (Blind-spot Collision Warning)	To activate or deactivate the Blind-spot Collision Warning (BCW) system sound. <b>For more details, refer to the "Blind-spot Collision Warning (BCW) system" in chapter 5.</b>

### 2. Door

Items	Explanation
Auto Lock	<ul style="list-style-type: none"> <li>• Disable : The auto door lock operation will be deactivated.</li> <li>• Enable on Speed: All doors will be automatically locked when the vehicle speed exceeds 15 km/h (9 mph).</li> <li>• Enable on Shift: All doors will be automatically locked if the automatic transaxle shift lever is shifted from the P (Park) position to the R (Reverse), N (Neutral), or D (Drive) position.</li> </ul>
Auto Unlock	<ul style="list-style-type: none"> <li>• Disable : The auto door unlock operation will be canceled.</li> <li>• On key out/On vehicle off : All doors will be automatically unlocked when the ignition key is removed from the ignition switch or the Engine Start/Stop button is set to the OFF position.</li> <li>• On Shift to P: All doors will be automatically unlocked if the automatic transmission shift lever is shifted to the P (Park) position.</li> </ul>
Power tailgate	<p>If this item is checked, the power tailgate function will be activated.</p> <p><b>For more details, refer to "Power tailgate" in this chapter.</b></p>
Smart tailgate	<p>To activate or deactivate the smart tailgate.</p> <p><b>For more details, refer to "Smart tailgate" in this chapter.</b></p>

### 3. Lights

Items	Explanation
One Touch Turn Signal	<ul style="list-style-type: none"> <li>• Off: The one touch turn signal function will be deactivated.</li> <li>• 3, 5, 7 Flashes: The turn signal indicator will blink 3, 5, or 7 times when the turn signal lever is moved slightly.</li> </ul> <p><b>For more details, refer to "Lighting" in this chapter.</b></p>
Head Lamp Delay	<p>To activate or deactivate the headlamp delay function.</p> <p><b>For more details, refer to "Lighting" in this chapter.</b></p>

### 4. Sound

Items	Explanation
Volume for PDW (Parking Distance Warning)	<p>To adjust the volume of the Parking Distance Warning (PDW) system. (Level 1~3)</p> <p><b>For more details, refer to the "Parking Distance Warning (PDW)" in chapter 5.</b></p>
Welcome sound	<p>To activate or deactivate the welcome sound.</p>

### 5. Convenience

Items	Explanation
Welcome mirror/light	To activate or deactivate the welcome mirror and welcome light function.
Wireless Charging System	To activate or deactivate the wireless charging system in the front seat. <b>For more details, refer to "Wireless Charging System" in this chapter.</b>
Wiper/Lights Display	To activate or deactivate the Wiper/ Light mode. When activated, the LCD display shows the selected Wiper/Light mode whenever you changed the mode.
Auto Rear Wiper (in R)	<ul style="list-style-type: none"> <li>• Off : The Auto Rear Wiper function will be deactivated.</li> <li>• ON : If you move the shift lever from D to R when the front wiper operates, the rear wiper will operate automatically. Then, if you move the shift lever from R to D, the rear wiper will stop.</li> </ul>
Gear Position Pop-up	To activate or deactivate the gear position pop-up. When activated, the gear position will be displayed on the LCD display.
Icy road warning	To activate or deactivate the icy road warning.

## 6. Service interval

Items	Explanation
Service Interval	To activate or deactivate the service interval function.
Adjust Interval	If the service interval menu is activated, you may adjust the time and distance.
Reset	To reset the service interval.

### Information

**To use the service interval menu, consult an authorized HYUNDAI dealer.**

If the service interval is activated and the time and distance is adjusted, messages are displayed in the following situations each time the vehicle is turned on.

- Service in  
: Displayed to inform the driver the remaining mileage and days to service.
- Service required  
: Displayed when the mileage and days to service has been reached or passed.

### Information

**If any of the following conditions occur, the mileage and number of days to service may be incorrect.**

- **The battery cable is disconnected.**
- **The fuse switch is turned off.**
- **The battery is discharged.**



### 7. Other features

Items	Explanation
Fuel Economy Auto Reset	<ul style="list-style-type: none"> <li>• Fuel economy auto reset Off: The average fuel economy will not reset automatically whenever refueling.</li> <li>• After Ignition: When the engine has been OFF for 4 hours or longer the average fuel economy will reset automatically.</li> <li>• After Refueling: The average fuel economy will reset automatically after adding 6 liters (1.6 gallons) of fuel or more and after driving speed exceeds 1 km/h (1 mph).</li> </ul> <p><b>For more details, refer to "Trip Computer" in this chapter.</b></p>
Fuel Economy Unit	To select the fuel economy unit. (km/L, L/100, MPG)
Temperature Unit	To select the temperature unit. (°C, °F)
Tire Pressure Unit	To select the tire pressure unit. (psi, kPa, bar)

### 8. Language (if equipped)

Items	Explanation
Language	Choose the language. You can choose the language in AVN device.(if equipped)

### 9. Reset Settings

Items	Explanation
Reset Settings	You can reset the menus in the User Settings Mode. All menus in the User Settings Mode are reset to factory settings, except language and service interval.

## Warning messages

### **Shift to "P" position (for smart key system and auto- matic transaxle/dual clutch transmission)**

This warning message illuminates if you try to turn off the engine without the shift lever in P (Park) position.

At this time, the Engine Start/Stop button turns to the ACC position (If you press the Engine Start/Stop button once more, it will turn to the ON position).

### **Low Key Battery (for smart key system)**

This warning message illuminates if the battery of the smart key is discharged while changing the Engine Start/Stop button while changing to the OFF position.

### **Press start button while turning wheel (for smart key system)**

This warning message illuminates if the steering wheel does not unlock normally when the Engine Start/Stop button is pressed.

You should press you should press the Engine Start/Stop button while turning the steering wheel right and left.

### **Steering wheel unlocked (for smart key system)**

This warning message illuminates if the steering wheel does not lock while the Engine Start/Stop button changes to the OFF position.

### **Check steering wheel lock system (for smart key system)**

This warning message illuminates if the steering wheel does not lock normally while the Engine Start/Stop button changes to the OFF position.

### **Press brake pedal to start engine (for smart key system and auto- matic transaxle)**

This warning message illuminates if the Engine Start/Stop button changes to the ACC position twice by pressing the button repeatedly without depressing the brake pedal.

You can start the vehicle by depressing the brake pedal.

### **Press clutch pedal to start engine (for smart key system and manual transaxle)**

This warning message illuminates if the Engine Start/Stop button is in the ACC position twice by pressing the button repeatedly without depressing the clutch pedal.

Depress the clutch pedal to start the engine.

### **Key not in vehicle (for smart key system)**

This warning message illuminates if the smart key is not in the vehicle when you press the Engine Start/Stop button.

It means that you always have the smart key with you.

### **Key not detected (for smart key system)**

This warning message illuminates if the smart key is not detected when you press the Engine Start/Stop button.

### **Press start button again (for smart key system)**

This warning message illuminates if you can not operate the Engine Start/Stop button when there is a problem with the Engine Start/Stop button system.

You could start the engine by pressing the Engine Start/Stop button once more.

If the warning illuminates each time you press the Engine Start/Stop button, we recommend that you have the vehicle inspected by an authorized HYUNDAI dealer.

### **Press "START" button with key (for smart key system)**

This warning message illuminates if you press the Engine Start/Stop button while the warning message "Key not detected" is displayed.

At this time, the immobilizer indicator light blinks.

### **Check "BRAKE SWITCH" fuse (for smart key system and automatic transaxle/dual clutch transmission)**

This warning message illuminates if the brake switch fuse is disconnected.

You need to replace the fuse with a new one. If that is not possible, you can start the engine by pressing the Engine Start/Stop button for 10 seconds in the ACC position.

### **Shift to "P" or "N" to start engine (for smart key system and automatic transaxle/dual clutch transmission)**

This warning message illuminates if you try to start the engine with the shift lever not in the P (Park) or N (Neutral) position.

### **Information**

**You can start the engine with the shift lever in the N (Neutral) position. But, for your safety, we recommend that you start the engine with the shift lever in the P (Park) position.**

### Door, Hood, Tailgate Open

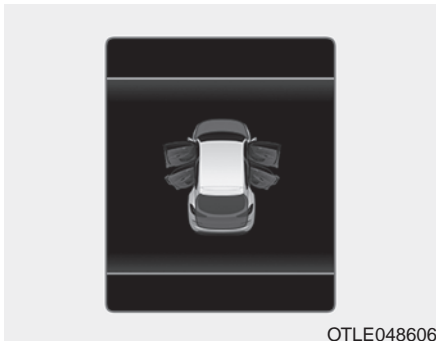

This warning illuminates, when any door, hood, or trunk is open.

### Sunroof Open (if equipped)

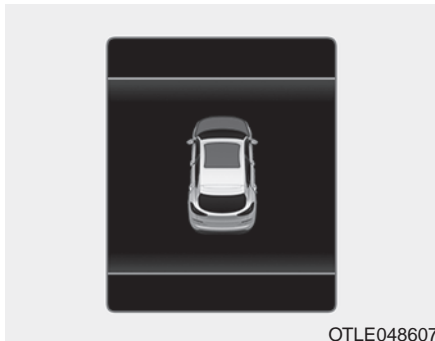

This warning illuminates if you turn off the engine when the sunroof is open.

### Lights mode

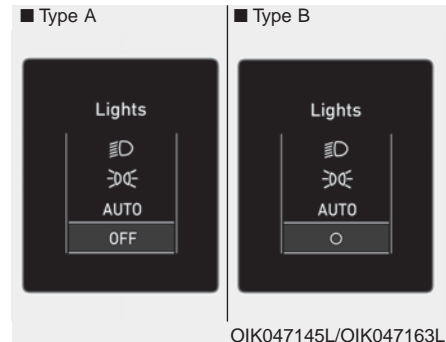

This indicator displays which exterior light is selected using the lighting control.

#### CAUTION

**Before driving the vehicle, you should confirm that the door/hood/tailgate is fully closed. Also, check there is no door/hood/tailgate open warning light or message displayed on the instrument cluster.**

### Wiper mode

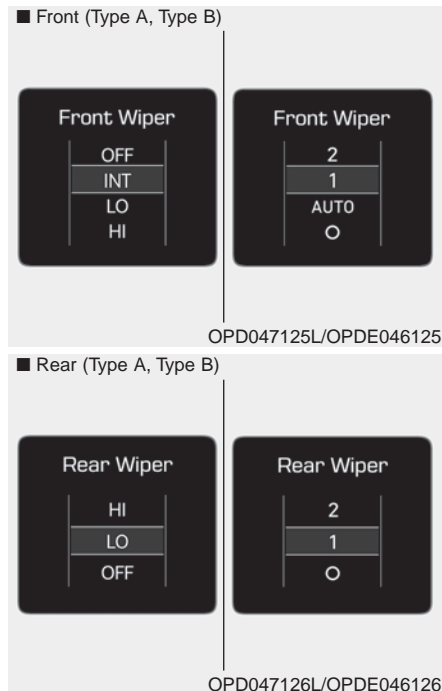

This indicator displays which wiper speed is selected using the wiper control.

### Heated Steering Wheel Off (if equipped)



This message illuminates if the heated steering wheel will turn off automatically approximately 30 minutes after the heated steering wheel is turned on.

**For more details, refer to “Heated Steering Wheel” in this chapter.**

### Low Tire Pressure (if equipped)



This warning message illuminates if the tire pressure is low with the ignition switch in ON position.

**For more details, refer to “Tire Pressure Monitoring System (TPMS)” in chapter 6.**

### Turn FUSE SWITCH on



This warning message illuminates if the fuse switch located on the fuse box under the steering wheel is OFF. You should turn the fuse switch on.

**For more details, refer to “Fuses” in chapter 7.**

### Low Washer Fluid (if equipped)

This warning message illuminates in the service reminder mode if the washer fluid level in the reservoir is nearly empty.

Refill the washer fluid.

### Low Fuel

This warning message illuminates if the fuel tank is nearly empty.

- When the low fuel level warning light is illuminates.
- When the trip computer displays “--- km(or mile)” as distance to empty.

Add fuel as soon as possible.

### Check 48V system (if equipped)



This warning message illuminates when there is a problem with the mild hybrid control system.

Refrain from driving when the warning message is displayed.

In this case, we recommend that you have your vehicle inspected by an authorized HYUNDAI dealer.

### ***Engine has overheated***

This warning message illuminates with a warning chime when the engine coolant temperature is above 120°C (248°F). This means that the engine is overheated and may be damaged.

**If your vehicle is overheated, refer to “Overheating” in chapter 6.**

### ***Check headlight (if equipped)***

This warning message is displayed if the headlamps are not operating properly.

In addition, if a specific lamp (turn signal lamp etc.) is not operating properly, the warning message according to a specific lamp (turn signal lamp etc.) is displayed. A corresponding bulb may need to be replaced.

### ***i* Information**

**Make sure to replace the burned out bulb with a new one of the same wattage rating.**

**If not, this warning message will not be displayed.**

### ***Low engine oil (if equipped)***

This warning message is displayed when the engine oil level should be checked.

If this warning message is displayed, check the engine oil level as soon as possible and add engine oil as required.

Slowly pour the recommended oil little by little into a funnel. (Oil refill capacity : approximately 0.6 ~ 1.0 l)

Use only the specified engine oil. (Refer to "Recommended lubricants and capacities" in chapter 8.)

Do not overfill the engine oil. Make sure the oil level is not above F (Full) mark on the dipstick.

### **NOTICE**

**If the message is displayed continuously after adding the engine oil and travelling approximately 50~100 km after the engine warms up, we recommend that the system be checked by an authorized HYUNDAI dealer.**

Even if this message is not displayed after the engine has started, the engine oil level should be periodically checked and topped up if required.

### **i** Information

If you travel approximately 50 km ~ 100 km after the engine warms up, after adding the engine oil, the warning message will be disappeared.

#### **Check High Beam Assist (HBA) system (if equipped)**

This warning message is displayed if there is a problem with the High Beam Assist (HBA) System. We recommend that you have the vehicle inspected by an authorized HYUNDAI dealer.

For more details, refer to "High Beam Assist (HBA) System" in chapter 3.

#### **Check FCA system (if equipped)**

This warning message is displayed if there is a malfunction with the Forward Collision-Avoidance Assist (FCA) system. We recommend that you have the vehicle inspected by an authorized HYUNDAI dealer.

For more details, refer to "Forward Collision-Avoidance Assist (FCA) system" in chapter 5.

#### **Check Driver Attention Warning (DAW) system (if equipped)**

This warning message is displayed if there is a problem with the Driver Attention Warning (DAW) system. We recommend that you have the vehicle inspected by an authorized HYUNDAI dealer.

For more details, refer to "Driver Attention Warning (DAW) system" in chapter 5.

#### **Check Forward Collision Warning system (if equipped)**

This warning message is displayed if there is a problem with the Forward Collision Warning (FCW) system. We recommend that you have the vehicle inspected by an authorized HYUNDAI dealer.

For more details, refer to "Forward Collision-Avoidance Assist (FCA) system" in chapter 5.

#### **Check Lane Keeping Assist (LKA) system (if equipped)**

This warning message is displayed if there is a problem with the Lane Keeping Assist (LKA) system. We recommend that you have the vehicle inspected by an authorized HYUNDAI dealer.

For more details, refer to "Lane Keeping Assist (LKA) system" in chapter 5.



***Check BCW (Blind-Spot Collision Warning) system***

This warning message is displayed if there is a problem with the Blind-Spot Collision Warning system. We recommend that you have the vehicle inspected by an authorized HYUNDAI dealer.

**For more details, refer to "Blind-Spot Collision Warning" in chapter 5.**

***Check exhaust system (if equipped)***

This warning message illuminates if the DPF or GPF system has a malfunction. At this time, DPF or GPF warning light also blinks.

In this case, we recommend that you have the DPF or GPF system checked by an authorized HYUNDAI dealer.

DPF : Diesel Particulate Filter

GPF : Gasoline Particulate Filter

**For more details, refer to "Warning lights" in this chapter.**

***Low urea (for diesel engine)***

This warning message illuminates if the urea solution level in the urea solution tank is nearly empty.

- When the SCR warning light is illuminated.

Refill urea solution as soon as possible.

**For more details, refer to "Low urea solution warning message" in the chapter 7.**

***Check urea system (for diesel engine)***

This warning message illuminates if the urea system has a malfunction.

In this case, we recommend that you have the urea system checked by an authorized HYUNDAI dealer.

**For more details, refer to "Low urea solution warning message" in the chapter 7.**

## TRIP COMPUTER

The trip computer is a microcomputer-controlled driver information system that displays information related to driving.

### **i** Information

Some driving information stored in the trip computer (for example Average Vehicle Speed) resets if the battery is disconnected.

### Trip modes

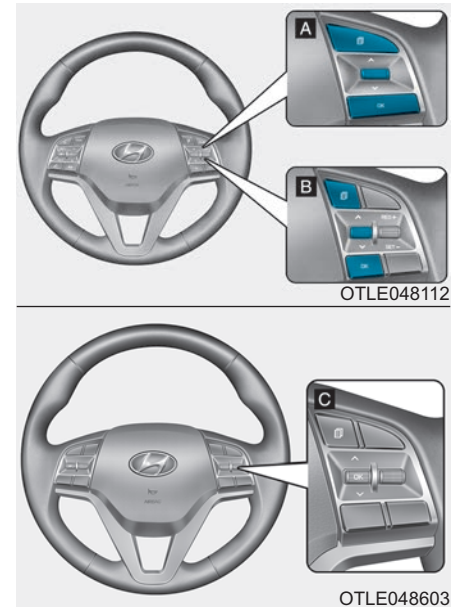
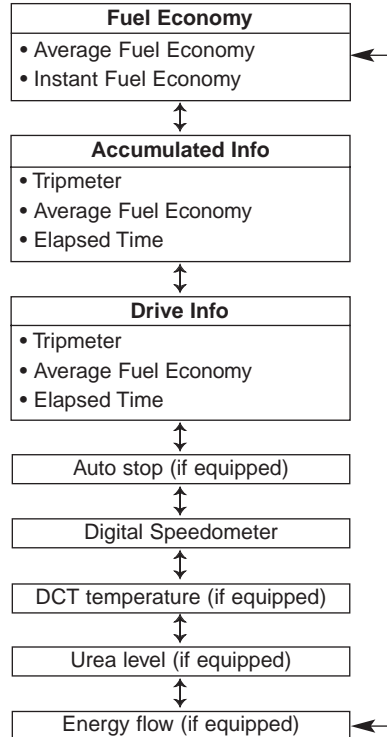

[A] : Type A, [B] : Type B, [C] : Type C

To change the trip mode, toggle the “^, v” switch on the steering wheel.

### Fuel economy

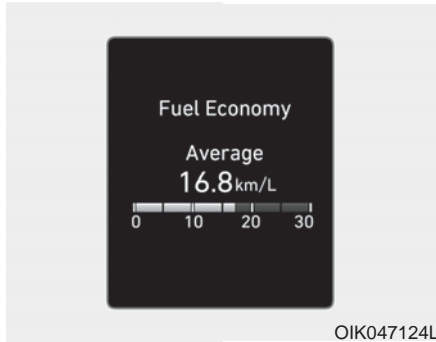

#### Average Fuel Economy (1)

- The average fuel economy is calculated by the total driving distance and fuel consumption since the last average fuel economy reset.
- The average fuel economy can be reset both manually and automatically.

#### Manual reset

To clear the average fuel economy manually, press the [OK] button on the steering wheel for more than 1 second when the average fuel economy is displayed.

#### Automatic reset

To automatically reset the average fuel economy after refueling, select the "Auto Reset" mode in the User Settings menu on the LCD display.

- After Ignition: The average fuel economy will reset automatically whenever it has passed 4 hours after turning OFF the engine.
- After Refueling: The average fuel economy will reset automatically when driving speed exceeds 1 km/h, after adding 6 liters (1.6 gallons) of fuel or more.

#### Information

**The average fuel economy may be inaccurate, when the vehicle drives shorter than 300 meters (0.19 miles) after turning ON the Engine Start/Stop button.**

#### Instant Fuel Economy (2)

- This mode displays the instant fuel economy during the last few seconds when the vehicle speed is more than 10 km/h (6 mph).

### Accumulated Info display

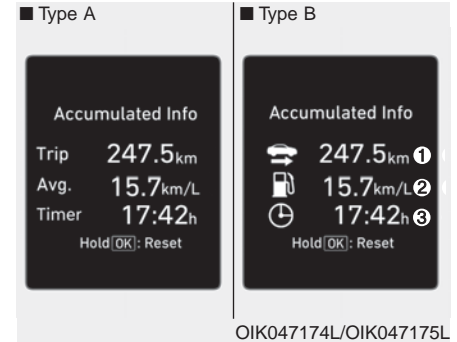

This display shows the accumulated trip distance (1), the average fuel economy (2), and the total driving time (3).

The information is accumulated starting from the last reset.

To manually reset the information, press and hold the OK button when viewing the Accumulated driving info. The trip distance, the average fuel economy, and total driving time will reset simultaneously.

The accumulated driving information will continue to be counted while the engine is still running (for example, when the vehicle is in traffic or stopped at a stop light).

### **i** Information

The vehicle must be driven for a minimum of 300 meters (0.19 miles) since the last ignition key cycle before the average fuel economy will be recalculated.

### **Drive Info display**

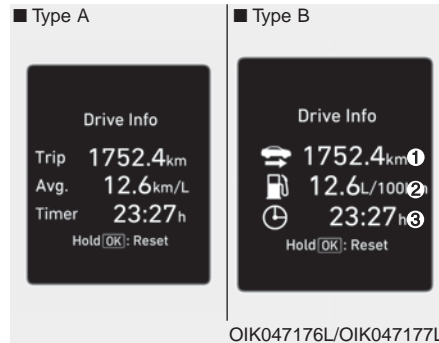

This display shows the trip distance (1), the average fuel economy (2), and the total driving time (3).

The information is combined for each ignition cycle. However, when the engine has been OFF for 4 hours or longer the Drive Info screen will reset.

To manually reset the information, press and hold the OK button when viewing the Drive Info. The trip distance, the average fuel economy, and total driving time will reset simultaneously.

The driving information will continue to be counted while the engine is still running (for example, when the vehicle is in traffic or stopped at a stop light.)

### **i** Information

The vehicle must be driven for a minimum of 300 meters (0.19 miles) since the last ignition key cycle before the average fuel economy will be recalculated.

***Auto stop time (if equipped)***



OTL045191L

This mode displays the elapsed time of Auto stop by "Idle stop and go system".

**For more details, refer to the "Idle stop and go system" in chapter 5.**

***Digital Speedometer***



OIK047151

This message shows the speed of the vehicle (km/h, MPH).

***DCT temperature (if equipped)***

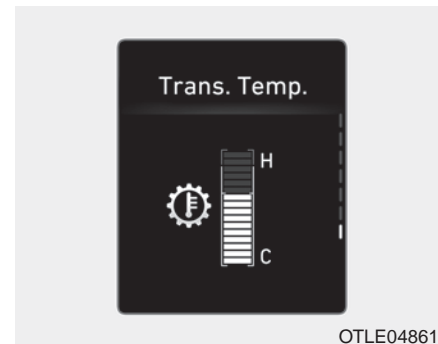

OTLE048611

This mode displays the temperature of dual clutch transmission.

**Urea level gauge  
(for diesel engine, if equipped)**



OTM048163L

This mode displays the amount of the remaining urea solution in the urea solution tank.

**Energy flow (for diesel 48V  
MHEV (Mild hybrid), if equipped)**

The mild hybrid system informs the drivers its energy flow in various operating modes. While driving, the current energy flow is specified in 3 modes.

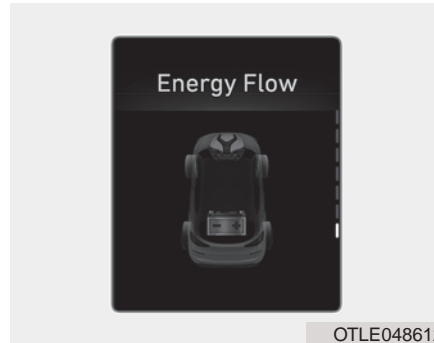

OTLE048612

**Vehicle stop**  
The vehicle is stopped.  
(No energy flow)



OTLE048613

**Engine Generation / Regeneration**  
The engine and regenerative brake system charges up the high-voltage battery.  
(Engine & Wheel → Battery)



### **Power Assist**

Both the motor and the engine power are used to drive the vehicle.  
(Battery & Engine → Wheel)

## WARNING AND INDICATOR LIGHTS

### Warning lights

#### **i** Information

Make sure that all warning lights are OFF after starting the engine. If any light is still ON, this indicates a situation that needs attention.

#### *Air bag Warning Light*



#### **This warning light illuminates:**

- Once you set the ignition switch or the Engine Start/Stop button to the ON position.
  - It illuminates for approximately 6 seconds and then goes off.
- When there is a malfunction with the SRS.

In this case, we recommend that you have the vehicle inspected by an authorized HYUNDAI dealer.

#### *Seat Belt Warning Light*



This warning light informs the driver that the seat belt is not fastened.

**For more details, refer to the “Seat Belts” in chapter 2.**



### ***Parking Brake & Brake Fluid Warning Light***



#### **This warning light illuminates:**

- Once you set the ignition switch or the Engine Start/Stop button to the ON position.
  - It illuminates for approximately 3 seconds
  - It remains on if the parking brake is applied.
- When the parking brake is applied.
- When the brake fluid level in the reservoir is low.
  - If the warning light illuminates with the parking brake released, it indicates the brake fluid level in reservoir is low.

If the brake fluid level in the reservoir is low:

1. Drive carefully to the nearest safe location and stop your vehicle.
2. With the engine stopped, check the brake fluid level immediately and add fluid as required (**For more details, refer to “Brake Fluid” in chapter 7**). Then check all brake components for fluid leaks. If any leak on brake system is still found, the warning light remains on, or the brakes do not operate properly, do not drive the vehicle.

In this case, we recommend that you have the vehicle towed to an authorized HYUNDAI dealer and inspected.

### **Dual-diagonal braking system**

Your vehicle is equipped with dual-diagonal braking systems. This means you still have braking on two wheels even if one of the dual systems should fail.

With only one of the dual systems working, more than normal pedal travel and greater pedal pressure are required to stop the vehicle.

Also, the vehicle will not stop in as short a distance with only a portion of the brake system working.

If the brakes fail while you are driving, shift to a lower gear for additional engine braking and stop the vehicle as soon as it is safe to do so.

## **⚠ WARNING**

### **Parking Brake & Brake Fluid Warning Light**

**Driving the vehicle with a warning light ON is dangerous. If the Parking Brake & Brake Fluid Warning Light illuminates with the parking brake released, it indicates that the brake fluid level is low.**

**In this case, we recommend that you have the vehicle inspected by an authorized HYUNDAI dealer.**

### **Anti-lock Brake System (ABS) Warning Light**



**This warning light illuminates:**

- Once you set the ignition switch or the Engine Start/Stop button to the ON position.
  - It illuminates for approximately 3 seconds and then goes off.
- When there is a malfunction with the ABS (The normal braking system will still be operational without the assistance of the anti-lock brake system).

In this case, we recommend that you have the vehicle inspected by an authorized HYUNDAI dealer.

### **Electronic Brake force Distribution (EBD) System Warning Light**



**These two warning lights illuminate at the same time while driving:**

- When the ABS and regular brake system may not work normally.

In this case, we recommend that you have the vehicle inspected by an authorized HYUNDAI dealer.

**⚠ WARNING**

**Electronic Brake force Distribution (EBD) System Warning Light**

When both ABS and Parking Brake & Brake Fluid Warning Lights are on, the brake system will not work normally and you may experience an unexpected and dangerous situation during sudden braking.

In this case, avoid high speed driving and abrupt braking.

We recommend you have the vehicle inspected by an authorized HYUNDAI dealer as soon as possible.

**i Information - Electronic Brake force Distribution (EBD) System Warning Light**

When the ABS Warning Light is on or both ABS and Parking Brake & Brake Fluid Warning Lights are on, the speedometer, odometer, or tripmeter may not work. Also, the EPS Warning Light may illuminate and the steering effort may increase or decrease.

In this case, we recommend you have the vehicle inspected by an authorized HYUNDAI dealer as soon as possible.

**Electronic Parking Brake (EPB) Warning Light (if equipped)**

**EPB**

**This warning light illuminates:**

- Once you set the ignition switch or the Engine Start/Stop button to the ON position.
  - It illuminates for approximately 3 seconds and then goes off.
- When there is a malfunction with the EPB.

In this case, we recommend that you have the vehicle inspected by an authorized HYUNDAI dealer.

**i Information**

The Electronic Parking Brake (EPB) Warning Light may illuminate when the Electronic Stability control (ESC) Indicator Light comes on to indicate that the ESC is not working properly (This does not indicate malfunction of the EPB).

## Electric Power Steering (EPS) Warning Light



### This warning light illuminates:

- Once you set the ignition switch or the Engine Start/Stop button to the ON position.
  - This indicator light comes on after the ignition key is turned to the ON position and then goes out after approximately 3 seconds.
- When there is a malfunction with the EPS.

In this case, we recommend that you have the vehicle inspected by an authorized HYUNDAI dealer.

## Malfunction Indicator Lamp (MIL)

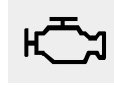

### This warning light illuminates:

- Once you set the ignition switch or the Engine Start/Stop button to the ON position.
  - It remains on until the engine is started.
- When there is a malfunction with the emission control system.

In this case, we recommend that you have the vehicle inspected by an authorized HYUNDAI dealer.

### **NOTICE**

Driving with the Malfunction Indicator Lamp (MIL) on may cause damage to the emission control systems which could affect drivability and/or fuel economy.

### **NOTICE** - Gasoline Engine

If the Malfunction Indicator Lamp (MIL) illuminates, potential catalytic converter damage is possible which could result in loss of engine power.

In this case, we recommend that you have the vehicle inspected by an authorized HYUNDAI dealer as soon as possible.

### **NOTICE** - Diesel Engine

If the Malfunction Indicator Lamp (MIL) blinks, some error related to the injection quantity adjustment occurs which could result in loss of engine power, combustion noise and poor emission.

In this case, we recommend that you have the engine control system inspected by an authorized HYUNDAI dealer.

## Charging System Warning Light



This warning light illuminates:

- Once you set the ignition switch or the Engine Start/Stop button to the ON position.
  - It remains on until the engine is started.
- When there is a malfunction with either the alternator or electrical charging system.

**If there is a malfunction with either the alternator or electrical charging system:**

1. Drive carefully to the nearest safe location and stop your vehicle.
2. Turn the engine off and check the alternator drive belt for looseness or breakage.

If the belt is adjusted properly, there may be a problem in the electrical charging system.

In this case, we recommend that you have the vehicle inspected by an authorized HYUNDAI dealer as soon as possible.

## Engine Oil Pressure Warning Light



This warning light illuminates:

- Once you set the ignition switch or the Engine Start/Stop button to the ON position.
  - It remains on until the engine is started.
- When the engine oil pressure is low.

**If the engine oil pressure is low:**

1. Drive carefully to the nearest safe location and stop your vehicle.
2. Turn the engine off and check the engine oil level (**For more details, refer to “Engine Oil” in chapter 7**). If the level is low, add oil as required. If the warning light remains on after adding oil or if oil is not available, we recommend that you have the vehicle inspected by an authorized HYUNDAI dealer as soon as possible.

### NOTICE

- If the engine does not stop immediately after the Engine Oil Pressure Warning Light is illuminated, severe damage could result.
- If the warning light stays on while the engine is running, it indicates that there may be serious engine damage or malfunction. In this case,
  1. Stop the vehicle as soon as it is safe to do so.
  2. Turn off the engine and check the oil level. If the oil level is low, fill the engine oil to the proper level.
  3. Start the engine again. If the warning light stays on after the engine is started, turn the engine off immediately. In this case, we recommend that you have the vehicle inspected by an authorized HYUNDAI dealer.

### **Engine Oil Level Warning Light (if equipped)**



The engine oil level warning light illuminates when the engine oil level should be checked.

If the warning light comes on, check the engine oil level as soon as possible and add engine oil as required.

Slowly pour the recommended oil little by little into a funnel. (Oil refill capacity : approximately 0.6 ~ 1.0 l)

Use only the specified engine oil. (Refer to "Recommended lubricants and capacities" in chapter 8.)

Do not overfill the engine oil. Make sure the oil level is not above F (Full) mark on the dipstick.

#### **i Information**

- If you travel approximately 50 km ~100 km after the engine warms up, after adding the engine oil, the warning light will go off.

(Continued)

(Continued)

- Cycle the ignition from OFF to ON 3 times within 10 seconds, the warning light will go off immediately. However, when you turn off the warning light without adding the engine oil, the light will come on again after traveling approximately 50 ~ 100 km after the engine warms up.

#### **NOTICE**

If the light comes on continuously after adding the engine oil and travelling approximately 50~100 km after the engine warms up, we recommend that the system be checked by an authorized HYUNDAI dealer.

Even if this light doesn't come on after the engine has started, the engine oil should be checked and supplied periodically.

### **Low Fuel Level Warning Light**



**This warning light illuminates:**

When the fuel tank is nearly empty. Add fuel as soon as possible.

#### **NOTICE**

Driving with the Low Fuel Level warning light on or with the fuel level below "0 or E" can cause the engine to misfire and damage the catalytic converter (if equipped).

### ***Overspeed Warning Light (if equipped)***

**120  
km/h**

#### **This warning light blinks:**

- When you drive the vehicle more than 120 km/h.
  - This is to prevent you from driving your vehicle with overspeed.
  - The overspeed warning chime also sound for approximately 5 seconds.

### ***Master Warning Light***



#### **This indicator light illuminates:**

- When there is a malfunction in the below systems.
  - Low washer fluid (if equipped)
  - Exterior lamp malfunction (if equipped)
  - Blind-Spot Collision Warning (BCW) malfunction (if equipped)
  - Tire Pressure Monitoring System (TPMS, if equipped)

To identify the details of the warning, look at the LCD display.

### ***Low Tire Pressure Warning Light (if equipped)***



#### **This warning light illuminates:**

- Once you set the ignition switch or Engine Start/Stop button to the ON position.
  - It illuminates for approximately 3 seconds and then goes off.
- When one or more of your tires are significantly underinflated (The location of the underinflated tires are displayed on the LCD display).

**For more details, refer to “Tire Pressure Monitoring System (TPMS)” in chapter 6.**

This warning light remains on after blinking for approximately 60 seconds or repeats blinking and off at the intervals of approximately 3 seconds:

- When there is a malfunction with the TPMS.  
In this case, we recommend that you have the vehicle inspected by an authorized HYUNDAI dealer as soon as possible.

For more details, refer to "Tire Pressure Monitoring System (TPMS)" in chapter 6.

### WARNING

#### Safe Stopping

- The TPMS cannot alert you to severe and sudden tire damage caused by external factors.
- If you notice any vehicle instability, immediately take your foot off the accelerator pedal, apply the brakes gradually with light force, and slowly move to a safe position off the road.

### **Forward Collision-Avoidance Assist (FCA) system warning light (if equipped)**



This indicator light illuminates:

- When you set the ignition switch or Engine Start/Stop button to the ON position.
  - It illuminates for approximately 3 seconds and then goes off.
- When there is a malfunction with the FCA.

In this case, we recommend that you have the vehicle inspected by an authorized HYUNDAI dealer.

For more details, refer to "Forward Collision-Avoidance Assist (FCA) system" in chapter 5.

### **Fuel Filter Warning Light (Diesel Engine)**



This warning light illuminates:

- Once you set the ignition switch or Engine Start/Stop Button to the ON position.
  - It illuminates for approximately 3 seconds and then goes off.
- When water has accumulated inside the fuel filter.

In this case, remove the water from the fuel filter.

For more details, refer to "Fuel Filter" in chapter 7.



### NOTICE

- When the Fuel Filter Warning Light illuminates, engine power (vehicle speed & idle speed) may decrease.
- If you keep driving with the warning light on, engine parts (injector, common rail, high pressure fuel pump) may be damaged. If this occurs, we recommend that you have the vehicle inspected by an authorized HYUNDAI dealer as soon as possible.

### 4 Wheel Drive (4WD) Warning Light (if equipped)



#### This warning light illuminates:

- Once you set the ignition switch or Engine Start/Stop Button to the ON position.
  - It illuminates for approximately 3 seconds and then goes off.
- When there is a malfunction with the 4WD system.

In this case, we recommend that you have the vehicle inspected by an authorized HYUNDAI dealer.

### Headlight Warning Light (if equipped)



#### This warning light illuminates:

- When there is a malfunction (burned-out bulb except LED light or circuit malfunction) with the exterior lights (headlight, brake light, fog light, etc.). In this case, we recommend that you have your vehicle inspected by an authorized HYUNDAI dealer.

### Information

**Make sure to replace the burned out bulb with a new one of the same wattage rating.**

**If not, this warning message will not be displayed.**

### **Exhaust System (DPF) Warning Light (Diesel Engine, if equipped)**



This warning light illuminates:

- When there is a malfunction with Diesel Particulate Filter (DPF) system.
- When this warning light illuminates, it may turn off after driving the vehicle:
  - at more than 60 km/h (37 mph), or
  - at more than 2nd gear with 1500 ~ 2000 engine rpm for a certain time (for about 25 minutes).

If this warning light blinks in spite of the procedure (at this time LCD warning message will be displayed), we recommend that you have the DPF system checked by an authorized HYUNDAI dealer.

#### **NOTICE**

If you continue to drive with the DPF warning light blinking for a long time, the DPF system can be damaged and fuel consumption can worsen.

### **Exhaust System (GPF) Warning Light (Gasoline Engine, if equipped)**



This warning light illuminates:

- When accumulated soot reaches a certain amount.
- When this warning light illuminates, it may turn off after driving the vehicle under the following condition:
  - at more than 80 km/h (50 mph) for about 30 minutes (above 3rd gear with 1500 ~ 4000 engine rpm).

If this warning light blinks in spite of the procedure (at this time LCD warning message will be displayed), we recommend that you have the GPF system checked by an authorized HYUNDAI dealer.

#### **NOTICE**

If you continue to drive with the GPF warning light blinking for a long time, the GPF system can be damaged and fuel consumption can worsen.

### **SCR warning light (Diesel Engine, if equipped)**



This warning light illuminates:

- When the urea solution tank is nearly empty.
  - If the urea solution tank is nearly empty:
- Refill urea solution as soon as possible.

**For more details, refer to "Low urea solution warning message" in the chapter 7.**

## Indicator lights

### **Electronic Stability Control (ESC) Indicator Light (if equipped)**



#### **This indicator light illuminates:**

- Once you set the ignition switch or the Engine Start/Stop button to the ON position.
  - It illuminates for approximately 3 seconds and then goes off.
- When there is a malfunction with the ESC system.

In this case, we recommend that you have the vehicle inspected by an authorized HYUNDAI dealer.

#### **This indicator light blinks:**

- While the ESC is operating.

**For more details, refer to “Electronic Stability Control (ESC)” in chapter 5.**

### **Electronic Stability Control (ESC) OFF Indicator Light (if equipped)**



#### **This indicator light illuminates:**

- Once you set the ignition switch or the Engine Start/Stop button to the ON position.
  - It illuminates for approximately 3 seconds and then goes off.
- When you deactivate the ESC system by pressing the ESC OFF button.

**For more details, refer to “Electronic Stability Control (ESC)” in chapter 5.**

### **AUTO STOP Indicator Light (if equipped)**



#### **This indicator light illuminates:**

- When the engine enters the Idle Stop mode of the ISG (Idle Stop and Go) system.
- When the automatic starting occurs, the AUTO STOP indicator on the cluster will blink for 5 seconds.

**For more details, refer to the “ISG (Idle Stop and Go) system” in chapter 5.**

#### **Information**

When the engine automatically starts by the ISG system, some warning lights (ABS, ESC, ESC OFF, EPS or Parking brake warning light) may turn on for a few seconds.

This happens because of low battery voltage. It does not mean the system has malfunctioned.

**Immobilizer Indicator Light (without smart key) (if equipped)**



**This indicator light illuminates:**

- When the vehicle detects the immobilizer in your key properly while the ignition switch is ON.
  - At this time, you can start the engine.
  - The indicator light goes off after starting the engine.

**This indicator light blinks:**

- When there is a malfunction with the immobilizer system.

In this case, we recommend that you have the vehicle inspected by an authorized HYUNDAI dealer.

**Immobilizer Indicator Light (With Smart Key) (if equipped)**



**This indicator light illuminates for up to 30 seconds:**

- When the vehicle detects the smart key in the vehicle properly while the Engine Start/Stop button is ACC or ON.
  - At this time, you can start the engine.
  - The indicator light goes off after starting the engine.

**This indicator light blinks for a few seconds:**

- When the smart key is not in the vehicle.
  - At this time, you cannot start the engine.

**This indicator light illuminates for 2 seconds and goes off:**

- When the vehicle cannot detect the smart key which is in the vehicle while the Engine Start/Stop button is ON.

In this case, we recommend that you have the vehicle inspected by an authorized HYUNDAI dealer.

**This indicator light blinks:**

- When the battery of the smart key is weak.
  - At this time, you can not start the engine. However, you can start the engine if you press the Engine Start/Stop button with the smart key. **(For more details, refer to “Starting the Engine” in chapter 5).**
- When there is a malfunction with the immobilizer system.

In this case, we recommend that you have the vehicle inspected by an authorized HYUNDAI dealer.

### **Turn Signal Indicator Light**

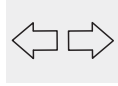

#### **This indicator light blinks:**

- When you turn the turn signal light on.

If any of the following occurs, there may be a malfunction with the turn signal system. In this case, we recommend that you have the vehicle inspected by an authorized HYUNDAI dealer.

- The indicator light does not blink but illuminates.
- The indicator light blinks more rapidly.
- The indicator light does not illuminate at all.

### **Low Beam Indicator Light (if equipped)**



#### **This indicator light illuminates:**

- When the headlights are on.

### **High Beam Indicator Light**



#### **This indicator light illuminates:**

- When the headlights are on and in the high beam position
- When the turn signal lever is pulled into the Flash-to-Pass position.

### **High Beam Assist (HBA) indicator light (if equipped)**



#### **This warning light illuminates:**

- When the high-beam is on with the light switch in the AUTO light position.
- If your vehicle detects oncoming or preceding vehicles, the High Beam Assist (HBA) system will switch the high beam to low beam automatically.

**For more details, refer to "High Beam Assist (HBA)" in this chapter.**

### **Light ON Indicator Light**



**This indicator light illuminates:**

- When the tail lights or headlights are on.

### **Front Fog Indicator Light (if equipped)**



**This indicator light illuminates:**

- When the front fog lights are on.

### **Rear Fog Indicator Light (if equipped)**



**This indicator light illuminates:**

- When the rear fog lights are on.

### **Glow Indicator Light (Diesel Engine)**



**This indicator light illuminates:**

- When the engine is being preheated with the ignition switch or Engine Start/Stop Button in the ON position.
  - The engine can be started after the glow indicator light goes off.
  - The illumination time varies with the engine coolant temperature, air temperature, and battery condition.

If the indicator light remains on or blinks after the engine has warmed up or while driving, there may be a malfunction with the engine preheating system.

In this case, we recommend that you have the vehicle inspected by an authorized HYUNDAI dealer.

### **i Information**

If the engine does not start within 10 seconds after the preheating is completed, set the ignition switch or Engine Start/Stop Button to the LOCK or OFF position for 10 seconds and then to the ON position in order to preheat the engine again.

### **4 Wheel Drive (4WD) LOCK Indicator Light (if equipped)**



#### **This indicator light illuminates:**

- Once you set the ignition switch or Engine Start/Stop Button to the ON position.
  - It illuminates for approximately 3 seconds and then goes off.
- When you select 4WD Lock mode by pressing the 4WD LOCK button.
  - The 4WD LOCK mode is to increase the drive power when driving on wet pavement, snow covered roads and/or off-road.

#### **NOTICE**

**Do not use 4WD LOCK mode on dry paved roads or highway, it can cause noise, vibration or damage of 4WD related parts.**

### **AUTO HOLD Indicator Light (if equipped)**



#### **This indicator light illuminates:**

- [White] When you activate the auto hold system by pressing the AUTO HOLD button.
- [Green] When you stop the vehicle completely by depressing the brake pedal with the auto hold system activated.
- [Yellow] When there is a malfunction with the auto hold system.  
In this case, we recommend that you have the vehicle inspected by an authorized HYUNDAI dealer.

**For more details, refer to “Auto Hold” in chapter 5.**

### **Downhill Brake Control (DBC) Indicator Light (if equipped)**



#### **This warning light illuminates:**

- Once you set the ignition switch or Engine Start/Stop Button to the ON position.
  - It illuminates for approximately 3 seconds and then goes off.
- When you activate the DBC system by pressing the DBC button.

#### **This warning light blinks:**

- When the DBC is operating.

#### **This warning light illuminates yellow:**

- When there is a malfunction with the DBC system.  
In this case, we recommend that you have the vehicle inspected by an authorized HYUNDAI dealer.

**For more details, refer to “Downhill Brake Control (DBC) System” in chapter 5.**

***Lane Keeping Assist  
(LKA) system indicator  
light (if equipped)***



**This indicator light illuminates:**

- [Green] When the system operating conditions are satisfied.
- [White] The system operating conditions are not satisfied.
- [Yellow] When there is a malfunction with the lane keeping assist system.

In this case, we recommend that you have your vehicle inspected by an authorized HYUNDAI dealer.

**For more details, refer to "Lane Keeping Assist (LKA) system" in chapter 5.**



## LIGHT

### Exterior lights

#### Lighting control

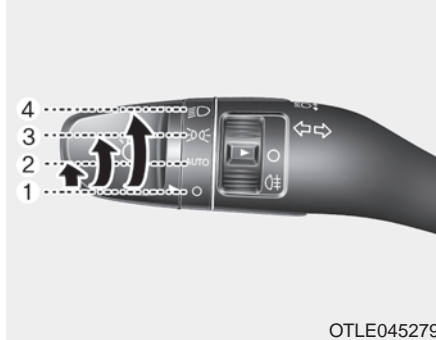

OTLE045279

To operate the lights, turn the knob at the end of the control lever to one of the following positions:

- (1) O (OFF) position
- (2) AUTO light position (if equipped)
- (3) Position lamp position
- (4) Headlamp position

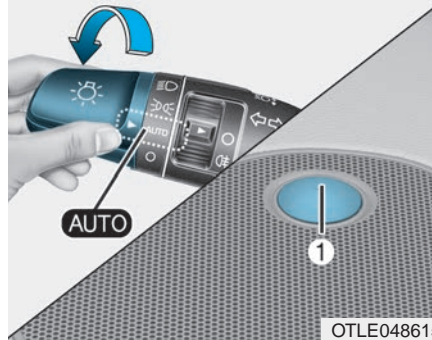

#### AUTO light position (if equipped)

When the light switch is in the AUTO position, the position lamp and headlamp will be turned ON or OFF automatically depending on the amount of light outside the vehicle.

Even with the AUTO light feature in operation, it is recommended to manually turn ON the lamps when driving at night or in a fog, or when you enter dark areas, such as tunnels and parking facilities.

#### NOTICE

- Do not cover or spill anything on the sensor (1) located on the instrument panel.
- Do not clean the sensor using a window cleaner, the cleanser may leave a light film which could interfere with sensor operation.
- If your vehicle has window tint or other types of metallic coating on the front windshield, the AUTO light system may not work properly.



OTLE045280

### Position lamp position ( 200E )

The position lamp, license plate lamp and instrument panel lamp are turned ON.



OTLE045283

### Headlamp position ( 200E )

The headlamp, position lamp, license plate lamp and instrument panel lamp are turned ON.

### **i** Information

The ignition switch button must be in the ON position to turn on the headlamp.

### High beam operation

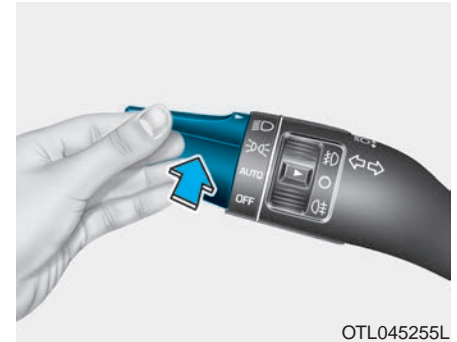

OTL045255L

To turn on the high beam headlamp, push the lever away from you. The lever will return to its original position.

The high beam indicator will light when the headlamp high beams are switched on.

To turn off the high beam headlamp, pull the lever towards you. The low beams will turn on.

### **⚠** WARNING

Do not use high beam when there are other vehicles approaching you. Using high beam could obstruct the other driver's vision.

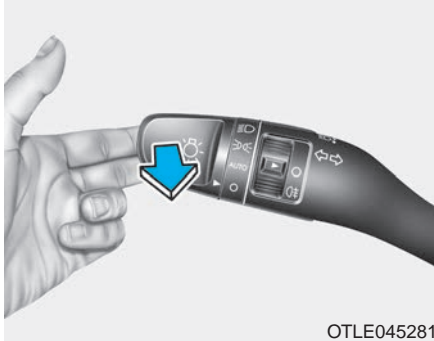

To flash the high beam headlamp, pull the lever towards you, then release the lever. The high beams will remain ON as long as you hold the lever towards you.

### **High Beam Assist (HBA) system (if equipped)**



High Beam Assist (HBA) is a system that automatically adjusts the headlamp range (switches between high beam and low beam) according to the brightness of other vehicles and road conditions.

#### **Operating condition**

1. Place the light switch in the AUTO position.
2. Turn on the high beam by pushing the lever away from you.
3. The High Beam Assist (HBA) (  ) indicator will illuminate.

4. The High Beam Assist (HBA) will turn on when vehicle speed is above 40 km/h (25 mph).

- 1) If the light switch is pushed away when the High Beam Assist (HBA) is operating, the High Beam Assist (HBA) will turn off and the high beam will be on continuously.
- 2) If the light switch is pulled towards you when the high beam is off, the high beam will turn on without the High Beam Assist (HBA) canceled. When you let go of the light switch, the lever will move to the middle and the high beam will turn off.
- 3) If the light switch is pulled towards you when the high beam is on by the High Beam Assist (HBA), the low beam will be on and the High Beam Assist (HBA) will turn off.
- 4) If the light switch is placed to the headlamp position, the High Beam Assist (HBA) will turn off and the low beam will be on continuously.

When the High Beam Assist (HBA) is operating, the high beam switches to low beam in the following conditions.

- When the headlamp of an on-coming vehicle is detected.
- When the tail lamp of a vehicle in front is detected.
- When headlamp/tail lamp of bicycle/motorcycle is detected.
- When the surroundings are bright enough high beams are not needed.
- When streetlights or other lights are detected.
- When the light switch is not in the AUTO position.
- When the High Beam Assist (HBA) is off.
- When vehicle speed is below 30 km/h (19 mph).

### Warning light and message

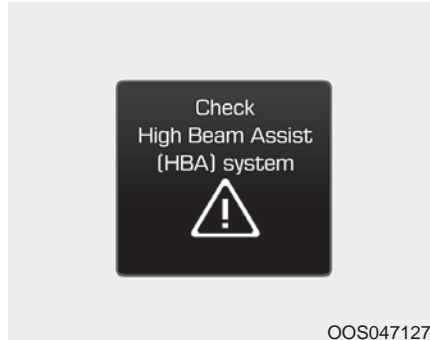

When the High Beam Assist (HBA) is not working properly, the warning message will come on for a few second. After the message disappears, the master warning light (⚠) will illuminate.

We recommend that you take your vehicle to an authorized HYUNDAI dealer and have the system checked.

### ⚠ CAUTION

The system may not operate normally in the following conditions.

- ▶ When the light from on-coming or vehicle in front is dim
- When the in light from the on-coming or vehicle in front in is not detected because of lamp damage, hidden from sight, etc.
- When the lamp of the on-coming or vehicle in front is covered with dust, snow or water.
- When the vehicle in front's headlamps are off but the fog lamps on and etc.

- ▶ When it is affected by an external condition
- When there is a similar shaped lamp with the vehicle front vehicle's lamps.
- When the headlamp is not repaired or replaced at an authorized dealer.
- When headlamp aiming is not properly adjusted.
- When driving on a narrow winding road or rough road.
- When driving downhill or uphill.
- When only part of the vehicle in front is visible on a cross-road or on a corner.
- When there is a traffic light, reflecting sign, flashing sign or mirror.
- When the road conditions are bad such as being wet or covered with snow.
- When the vehicle in front headlamps are off but the fog lamps on.

- When a vehicle suddenly appears from around a corner.
- When the vehicle is tilted from a flat tire or being towed.
- When the Lane Keeping Assist (LKA) system warning light illuminates. (if equipped)
- ▶ When the front visibility is poor
- When the lamp of the on-coming or vehicle in front is covered with dust, snow or water.
- When the light from the on-coming or vehicle in front is not detected because of exhaust fume, smoke, fog, snow, etc.
- When the front window is covered with foreign matter.
- When it is hard to see because of fog, heavy rain or snow etc.

### **WARNING**

- Do not disassemble a front view camera temporarily for tinted window or attaching any types of coatings and accessories. If you disassemble the camera and assemble it again, we recommend that you take your vehicle to an authorized HYUNDAI dealer and have the system checked to need a calibration.
- When you replace or reinstall the windshield glass, front view camera, we recommend that you take your vehicle to an authorized HYUNDAI dealer and have the system checked.
- Be careful that water doesn't get into the High Beam Assist (HBA) unit and do not remove or damage related parts of the High Beam Assist (HBA) system.

- Do not place objects on the crash pad that reflect light such as mirrors, white paper, etc. The system may malfunction if sunlight is reflected.
- At times, the High Beam Assist (HBA) may not work properly. The system is for your convenience only. It is the responsibility of the driver for safe driving practices and always check the road conditions for your safety.
- When the system does not operate normally, change the lamp position manually between the high beam and low beam.

### Turn signals and lane change signals

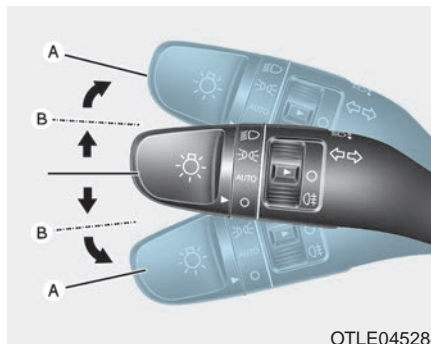

To signal a turn, push down on the lever for a left turn or up for a right turn in position (A). To signal a lane change, move the turn signal lever slightly and hold it in position (B). The lever will return to the OFF position when released or when the turn is completed.

If an indicator stays on and does not flash or if it flashes abnormally, one of the turn signal bulbs may be burned out and will require replacement.

### One-touch turn signal function

To activate an one-touch turn signal function, move the turn signal lever slightly and then release it. The lane change signals will blink 3, 5 or 7 times.

You can activate/deactivate the One Touch Turn Signal function or choose the number of blinking (3, 5, or 7) from the User Settings Mode on the LCD display. **For more details, refer to "LCD Display" in this chapter.**

### Front fog lamp (if equipped)



OTL047258L

Fog lamps are used to provide improved visibility when visibility is poor due to fog, rain or snow, etc. Use the switch next to the headlamp switch to turn the fog lamps ON and OFF.

1. Turn on the position lamp.
2. Turn the light switch (1) to the front fog lamp position.

3. To turn off the front fog lamp, turn the light switch to the front fog lamp position again or turn off the position lamp.

#### NOTICE

**When in operation, the fog lamps consume large amounts of vehicle electrical power. Only use the fog lamps when visibility is poor.**

### Rear fog lamp



OTL047278L

#### Vehicle with front fog lamp

To turn on the rear fog lamp:

Position the light switch in the position lamp position, turn the light switch (1) to the front fog lamp position, and then turn the light switch (1) to the rear fog lamp position.

To turn the rear fog lamps off, do one of the following:

- Turn off the parking light switch.
- Turn the light switch to the rear fog lamp position again.
- When the light switch is in the position lamp position, if you turn off the front fog lamp, the rear fog lamp will also turn off.



### Vehicle without front fog lamp

To turn on the rear fog lamp:

Position the light switch in the headlamp position, and then turn the light switch (1) to the rear fog lamp position.

To turn the rear fog lamps off, do one of the following:

- Turn off the headlamp switch.
- Turn the light switch to the rear fog lamp position again.

### Battery saver function

The purpose of this feature is to prevent the battery from being discharged. The system automatically turns off the position lamp when the driver turns the engine off and opens the driver-side door.

With this feature, the position lamps will turn off automatically if the driver parks on the side of road at night.

If necessary, to keep the lamps on when the engine is turned off, perform the following:

- 1) Open the driver-side door.
- 2) Turn the position lamps OFF and ON again using the light switch on the steering column.

### Headlamp delay function (if equipped)

If you place the ignition switch in to the ACC or OFF position with the headlamps ON, the headlamps (and/or position lamps) remain on for about 5 minutes. However, with the engine off if the driver's door is opened and closed, the headlamps (and/or position lamps) are turned off after 15 seconds.

The headlamps (and/or position lamps) can be turned off by pressing the lock button on the smart key twice or turning the light switch to the OFF or AUTO position. However, if you turn the light switch to the AUTO position when it is dark outside, the headlamps will not be turned off.

You can activate or deactivate the Headlamp Delay function from the User Settings Mode on the LCD display. **For more details, refer to "LCD Display" in this chapter.**



### **NOTICE**

If the driver gets out of the vehicle through other doors (except driver's door), the battery saver function does not operate and the headlamp delay function does not turn off automatically. Therefore, it causes the battery to be discharged. In this case, make sure to turn off the lamp before getting out of the vehicle.

### **Daytime running light (DRL) (if equipped)**

The Daytime Running Lights (DRL) can make it easier for others to see the front of your vehicle during the day, especially after dawn and before sunset.

The DRL system will turn the dedicated lamp OFF when:

1. The headlights or front fog lights are in the ON position.
2. The position lamp is in the ON position.
3. The engine is turned off.

### **Headlight leveling device**



#### **Manual type**

To adjust the headlight beam level according to the number of the passengers and loading weight in the luggage area, turn the beam leveling switch.

The higher the number of the switch position, the lower the headlight beam level. Always keep the headlight beam at the proper leveling position, or headlights may dazzle other road users.

Listed below are the examples of proper switch settings. For loading conditions other than those listed below, adjust the switch position so that the beam level may be the nearest as the condition obtained according to the list.

Loading condition	Switch position
Driver only	0
Driver + Front passenger	0
Full passengers (including driver)	1
Full passengers (including driver) + Maximum permissible loading	2
Driver + Maximum permissible loading	3

### Automatic type

It automatically adjusts the headlight beam level according to the number of passengers and loading weight in the luggage area.

And it offers proper headlight beam under various conditions.

### WARNING

**If it does not work properly even though your car is inclined backward according to passenger's posture, or the headlight beam is irradiated to the high or low position, we recommend that the system be inspected by an authorized HYUNDAI dealer. Do not attempt to inspect or replace the wiring yourself.**

### Headlamp washer (if equipped)



Washer fluid will be sprayed on the headlamps at the same time you operate the windshield washer when:

1. The ignition switch is in the ON position.
2. The light switch is in the headlamp position (low beam).

### Information

- Check the headlamp washers periodically to confirm that the washer fluid is being sprayed properly onto the headlamp lenses.
- The headlamp washer can be operated 15 minutes after the last operation.

### Low Beam Assist-Static light (if equipped)

While driving a corner, for greater visibility and safety, either the left or right side Low Beam Assist-Static light will turn on automatically. The Low Beam Assist-Static light will turn on when one of the following conditions occur.

- Vehicle speed is less than 10 km/h (6 mph) and steering wheel angle is turned approximately 80 degrees with the low beam on.
- Vehicle speed is between 10 km/h (6 mph) to 90 km/h (56 mph) and steering wheel angle is turned approximately 35 degrees with the low beam on.
- When the vehicle is in reverse with one of the conditions above satisfied, the light opposite to the direction the steering wheel is turned will turn on.

### Welcome system (if equipped)

#### *Welcome light (if equipped)*



#### **Puddle lamp (if equipped)**

When all the doors (and tailgate) are closed and locked, the puddle lamp will come on for about 15 seconds if any of the below is performed.

- When the door unlock button is pressed on the remote key or smart key.
- When the button of the outside door handle is pressed.
- When the vehicle is approached with the smart key in possession. (if equipped)

Also if “Convenience → Welcome mirror/ light” is selected in the User Settings mode on the LCD display and the outside rearview mirror folding switch is in the AUTO position, the outside rearview mirror will unfold automatically. (if equipped)

#### **Door handle lamp (if equipped)**

When all the doors (and tailgate) are closed and locked, the door handle lamp will come on for about 15 seconds if any of the below is performed.

- When the door unlock button is pressed on the remote key or smart key.
- When the button of the outside door handle is pressed.
- When “Convenience → Welcome mirror/ light” is selected in the User Settings mode on the LCD display and you approach the vehicle with the smart key in possession. (if equipped)

## Headlamp and Position lamp

When the headlamp (lamp switch in the headlamp or AUTO position) is on and all doors (and tailgate) are locked and closed, the position lamp and headlamp will come on for 15 seconds if/or any of the below is performed.

- When the door unlock button is pressed on the remote key or smart key.

At this time, if you press the door lock or unlock button, the position lamp and headlamp will turn off immediately.

You can activate or deactivate the Welcome Light from the User Settings Mode on the LCD display. **For more details, refer to "LCD Display" in this chapter.**

## Interior lamp

When the interior lamp switch is in the DOOR position and all doors (and tailgate) are closed and locked, the room lamp will come on for 30 seconds if any of the below is performed.

- When the door unlock button is pressed on the remote key or smart key.
- When the button of the outside door handle is pressed.

At this time, if you press the door lock or unlock button, the room lamp will turn off immediately.

## Interior lights

### NOTICE

**Do not use the interior lights for extended periods when the engine is turned off or the battery will discharge.**

### WARNING

**Do not use the interior lights when driving in the dark. The interior lights may obscure your view and cause an accident.**

### Interior lamp AUTO cut

The interior lamps will automatically go off approximately 20 minutes after the engine is turned off and the doors closed. If a door is opened, the lamp will go off 40 minutes after the engine is turned off. If the doors are locked and the vehicle enters the armed stage of the theft alarm system, the lamps will go off five seconds later.

### Front lamps

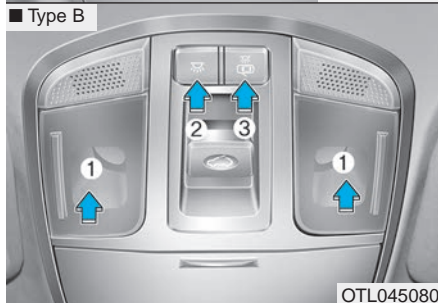
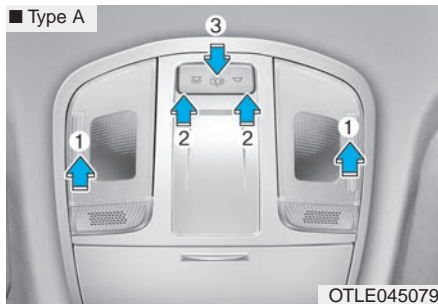

- (1) Front Map Lamp
- (2) Front Room Lamp
- (3) Front Door Lamp

### Front map lamp

Press the map lamp lens (1) to turn ON the map lamp. Re-press the map lamp cover to turn OFF the map lamp.

### Front room lamp



(Type A) Press the button to turn ON the room lamp for the front/rear seats.

(Type B) Press the button to turn ON the room lamp for the front/rear seats. Re-press the button to turn OFF the room lamp.



(Type A) Press the button to turn OFF the room lamp for the front/rear seats.

### Front door lamp ( )

The room lamp for the front/rear seats is automatically turned ON for approximately 30 seconds, when a door is opened.

The room lamp for the front/rear seats is automatically turned ON for approximately 15 seconds, when the remote key (smart key) unlocks the doors. The room lamp fades out, when the ignition switch is pressed to the ON position in 15 seconds. The room lamp remains ON up to 20 minutes, when a door is opened with the ignition switch in the either the ACC or OFF position.

## Rear lamps

■ Type A



■ Type B

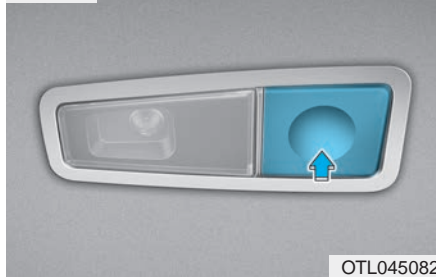

Rear room lamp switch (  ) :

Press this button to turn the room lamp on and off.

### NOTICE

Do not leave the lamp switches on for an extended period of time when the engine is turned off.

## Tailgate room lamp



The tailgate room lamp comes on when the tailgate is opened.

### NOTICE

The tailgate lamp comes on as long as the tailgate lid is open. To prevent unnecessary charging system drain, close the tailgate lid securely after using the tailgate.

## Glove box lamp

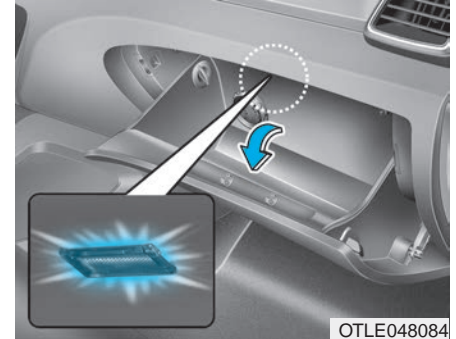

The glove box lamp comes on when the glove box is opened. If the glove box is not closed, the lamp will turn off after 20 minutes.



### NOTICE

To prevent unnecessary charging system drain, close the glove box securely after using the glove box.

### Vanity mirror lamp



Push the switch to turn the light on or off.

-  : The lamp will turn on if this button is pressed.
-  : The lamp will turn off if this button is pressed.

#### **NOTICE**

**Always have the switch in the off position when the vanity mirror lamp is not in use. If the sunvisor is closed without the lamp off, it may discharge the battery or damage the sunvisor.**

### Puddle lamp (if equipped)

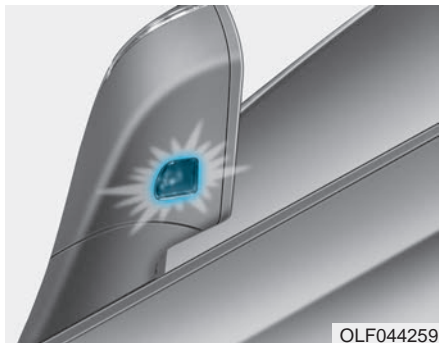

#### Welcome light

When all doors (and tailgate) are closed and locked, the puddle lamp will come on for 15 seconds if the door is unlocked by the smart key or outside door handle button.

**For more details, refer to "Welcome System" in this chapter.**

### Escort light

When the ignition switch is in the OFF position and the driver's door is opened, the puddle lamp will come on for 30 seconds. If the driver's door is closed within the 30 seconds, the puddle lamp will turn off after 15 seconds. If the driver's door is closed and locked, the puddle lamp will turn off immediately.

The Puddle Lamp Escort Light will turn on only the first time the driver's door is opened after the engine is turned off.



## WIPERS AND WASHERS

### ■ Front windshield wiper/washer

• Type A

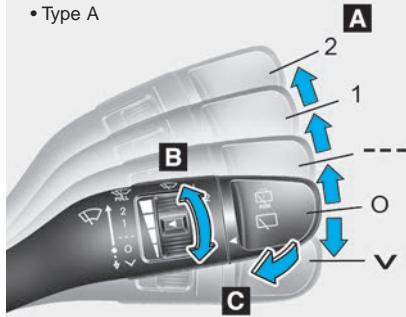

• Type B

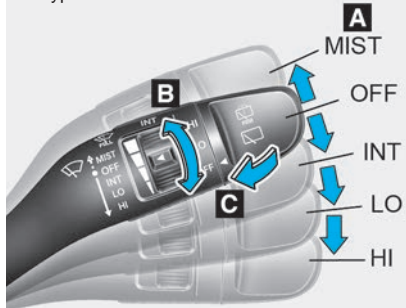

### ■ Rear windshield wiper/washer

• Type A

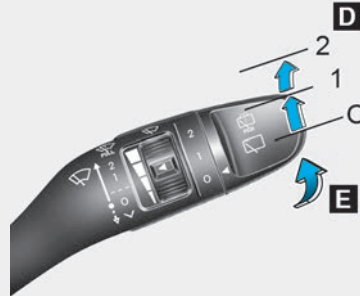

• Type B

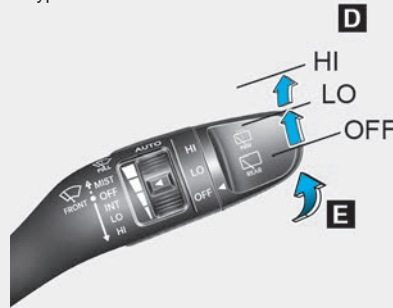

### A : Wiper speed control (front)

- √ / MIST – Single wipe
- 0 / OFF – Off
- --- / INT – Intermittent wipe  
AUTO\* – Auto control wipe
- 1 / LO – Low wiper speed
- 2 / HI – High wiper speed

### B : Intermittent control wipe time adjustment

### C : Wash with brief wipes (front)

### D : Rear wiper control\*

- 2 / HI – High wiper speed
- 1 / LO – Low wiper speed
- 0 / OFF – Off

### E : Wash with brief wipes (rear)

\* : if equipped

OTLE045159/OTLE045161/OTLE045507/OTLE045508



### Windshield wipers

Operates as follows when the ignition switch is turned ON.

∨/MIST : For a single wiping cycle, move the lever down (∨) or up (MIST) and release it. The wipers will operate continuously if the lever is held in this position.

O/OFF : Wiper is not in operation

---/INT : Wiper operates intermittently at the same wiping intervals. Use this mode in light rain or mist. To vary the speed setting, turn the speed control knob.

1/LO : Normal wiper speed

2/HI : Fast wiper speed

### **i** Information

**If there is heavy accumulation of snow or ice on the windshield, defrost the windshield for about 10 minutes, or until the snow and/or ice is removed before using the windshield wipers to ensure proper operation.**

**If you do not remove the snow and/or ice before using the wiper and washer, it may damage the wiper and washer system.**

### **AUTO (Automatic) control (if equipped)**

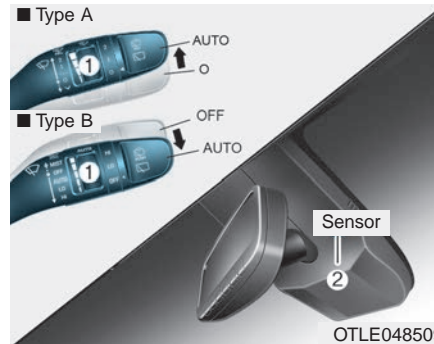

The rain sensor (2) located on the upper end of the windshield glass senses the amount of rainfall and controls the wiping cycle for the proper interval. The more it rains, the faster the wiper operates.

When the rain stops, the wiper stops. To vary the speed setting, turn the speed control knob (1).

If the wiper switch is set in AUTO mode when the ignition switch is in the ON position, the wiper will operate once to perform a self-check of the system. Set the wiper to OFF position when the wiper is not in use.

### **⚠ WARNING**

To avoid personal injury from the windshield wipers, when the engine is running and the windshield wiper switch is placed in the AUTO mode:

- Do not touch the upper end of the windshield glass facing the rain sensor.
- Do not wipe the upper end of the windshield glass with a damp or wet cloth.
- Do not put pressure on the windshield glass.

### **NOTICE**

- When washing the vehicle, set the wiper switch in the O (OFF) position to stop the auto wiper operation. The wiper may operate and be damaged if the switch is set in the AUTO mode while washing the vehicle.
- Do not remove the sensor cover located on the upper end of the passenger side windshield glass. Damage to system parts could occur and may not be covered by your vehicle warranty.

## Windshield washers

■ Type A

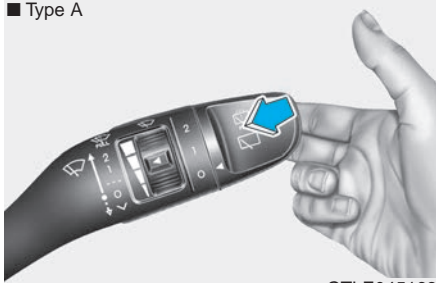

■ Type B

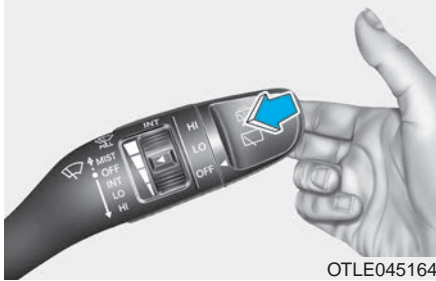

In the OFF (O) position, pull the lever gently toward you to spray washer fluid on the windshield and to run the wipers 1-3 cycles. The spray and wiper operation will continue until you release the lever.

If the washer does not work, you may need to add washer fluid to the washer fluid reservoir.

If equipped with the Headlamp Washer, washer fluid will be sprayed on the headlamp at the same time you operate the windshield washer when:

1. The ignition switch is in the ON position.
2. The light switch is in the headlamp position.

### ⚠ WARNING

When the outside temperature is below freezing, **ALWAYS** warm the windshield using the defroster to prevent the washer fluid from freezing on the windshield and obscuring your vision which could result in an accident and serious injury or death.

### ⚠ CAUTION

- To prevent possible damage to the washer pump, do not operate the washer when the fluid reservoir is empty.
- To prevent possible damage to the wipers or windshield, do not operate the wipers when the windshield is dry.
- To prevent damage to the wiper arms and other components, do not attempt to move the wipers manually.
- To prevent possible damage to the wipers and washer system, use anti-freezing washer fluids in the winter season or cold weather.

### Rear window wiper and washer switch (if equipped)

■ Type A

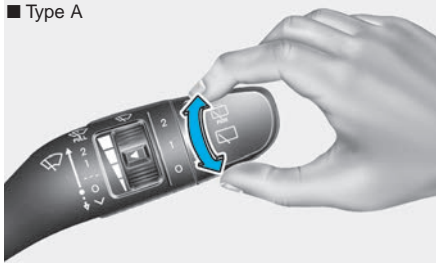

OTLE045167

■ Type B

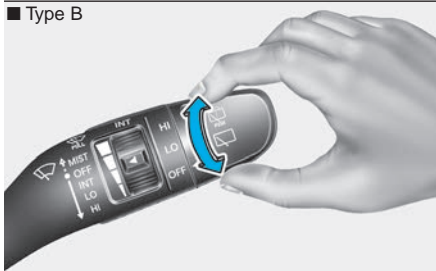

OTLE045165

The rear window wiper and washer switch is located at the end of the wiper and washer switch lever.

Turn the switch to the desired position to operate the rear wiper and washer.

2 / HI – High wiper speed

1 / LO – Low wiper speed

O / OFF – Off

■ Type A

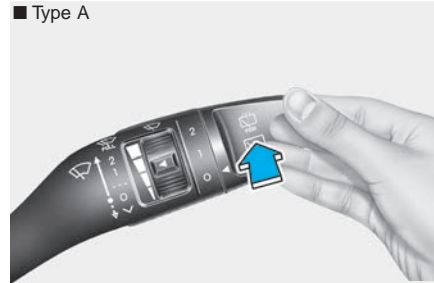

OTLE045168

■ Type B



OTLE045166

Push the lever away from you to spray rear washer fluid and to run the rear wipers 1~3 cycles. The spray and wiper operation will continue until you release the lever. (if equipped)

### Auto rear wiper (if equipped)

The rear wiper will operate while the vehicle is in reverse with the front wipers ON by selecting the function on the LCD display.

Go to 'User Settings → Convenience → Auto Rear Wiper (reverse)'.

## DRIVER ASSIST SYSTEM

### Parking Distance Warning (Reverse) system (if equipped)



[B] : Sensor

The Parking Distance Warning (Reverse) system assists the driver during reverse movement of the vehicle by chiming if any object is sensed within the distance of 120 cm (50 inches) behind the vehicle.

This system is a supplemental system that senses objects within the range and location of the sensors, it cannot detect objects in other areas where sensors are not installed.

### ⚠ WARNING



- **ALWAYS** look around your vehicle to make sure there are not any objects or obstacles before moving the vehicle in any direction to prevent a collision.
- **Always** pay close attention when the vehicle is driven close to objects, particularly pedestrians, and especially children.
- **Be aware that some objects may not be visible on the screen or be detected by the sensors, due to the objects distance, size or material, all of which can limit the effectiveness of the sensor.**

### *Operation of the Parking Distance Warning (Reverse) system*

#### Operating condition

- This system will activate when backing up with the ignition switch in the ON position. However, if vehicle speed exceeds 5 km/h (3 mph), the system may not detect objects.
- If vehicle speed exceeds 10 km/h (6 mph), the system will not warn you even though objects are detected.
- When more than two objects are sensed at the same time, the closest one will be recognized first.

### Types of warning sound and indicator

Types of warning sound	Indicator
When an object is 120 cm to 60 cm (47 in. to 24 in.) from the rear bumper : Buzzer beeps intermittently.	
When an object is 60 cm to 30 cm (24 in. to 12 in.) from the rear bumper : Buzzer beeps more frequently.	
When an object is within 30 cm (12 in.) of the rear bumper : Buzzer beeps continuously.	

#### NOTICE

- The indicator may differ from the illustration depending on objects or sensors status. If the indicator blinks, we recommend that you have your vehicle checked by an authorized HYUNDAI dealer.
- If the audible warning does not sound or if the buzzer sounds intermittently when shifting into R (Reverse) position, this may indicate a malfunction with Parking Distance Warning (Reverse) system. If this occurs, we recommend that you have your vehicle checked by an authorized HYUNDAI dealer as soon as possible.

### To turn off the Parking Distance Warning (Reverse) system (if equipped)

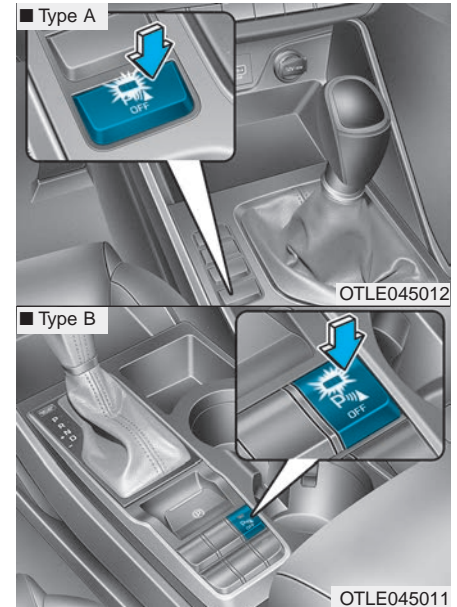

Push the button to turn off the Parking Distance Warning (Reverse) system. The indicator light on the button will turn on.

### ***Non-operational conditions of Parking Distance Warning (Reverse) system***

The Parking Distance Warning (Reverse) system may not operate normally when:

- Moisture is frozen to the sensor.
- Sensor is covered with foreign matter, such as snow or water, or the sensor cover is blocked.

There is a possibility of the Parking Distance Warning (Reverse) system malfunction when:

- Driving on uneven road surfaces such as unpaved roads, gravel, bumps, or gradient.
- Objects generating excessive noise such as vehicle horns, loud motorcycle engines, or truck air brakes can interfere with the sensor.
- Heavy rain or water spray is present.
- Wireless transmitters or mobile phones are present near the sensor.
- The sensor is covered with snow.
- Any non-factory equipment or accessories have been installed, or if the vehicle bumper height or sensor installation has been modified.

Detecting range may decrease when:

- Outside air temperature is extremely hot or cold.
- Undetectable objects smaller than 1 m (40 inches) and narrower than 14 cm (6 inches) in diameter.

The following objects may not be recognized by the sensor:

- Sharp or slim objects such as ropes, chains or small poles.
- Objects, which tend to absorb sensor frequency such as clothes, spongy material or snow.

#### **WARNING**

**Your new vehicle warranty does not cover any accidents or damage to the vehicle or injuries to its occupants related to a Parking Distance Warning (Reverse) system. Always drive safely and cautiously.**



### **Parking Distance Warning (Reverse) system precautions**

- The Parking Distance Warning (Reverse) system may not sound consistently depending on the speed and shapes of the objects detected.
- The Parking Distance Warning (Reverse) system may malfunction if the vehicle bumper height or sensor installation has been modified or damaged. Any non-factory installed equipment or accessories may also interfere with the sensor performance.
- The sensor may not recognize objects less than 30 cm (11 in.) from the sensor, or it may sense an incorrect distance. Use caution.
- When the sensor is frozen or stained with snow, dirt, or water, the sensor may be inoperative until the stains are removed using a soft cloth.
- Do not push, scratch or strike the sensor with any hard objects that could damage the surface of the sensor. Sensor damage could occur.
- Do not spray the sensors or its surrounding area directly with a high pressure washer. Shock applied from high pressure water may cause the device to not operate normally.

### **Parking Distance Warning (Reverse/Forward) system (if equipped)**

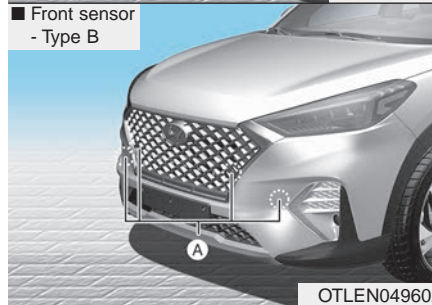
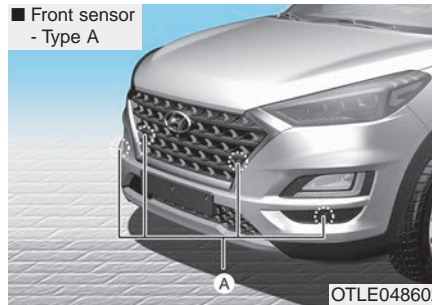

[A] : Front sensor, [B] : Rear sensor

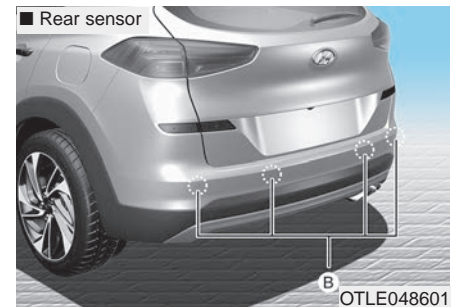

The Parking Distance Warning (Reverse/Forward) system assists the driver during movement of the vehicle by chiming if any object is sensed within the distance of 100 cm (39 inches) in front and 120 cm (47 inches) behind the vehicle.

This system is a supplemental system that senses objects within the range and location of the sensors, it cannot detect objects in other areas where sensors are not installed.

## ⚠ WARNING

- **ALWAYS** look around your vehicle to make sure there are no objects or obstacles before moving the vehicle in any direction to prevent a collision.
- Always pay close attention when the vehicle is driven close to objects, particularly pedestrians, and especially children.
- Be aware that some objects may not be visible on the screen or be detected by the sensors, due to the objects distance, size or material, all of which can limit the effectiveness of the sensor.

### Operation of the Parking Distance Warning (Reverse/Forward) system

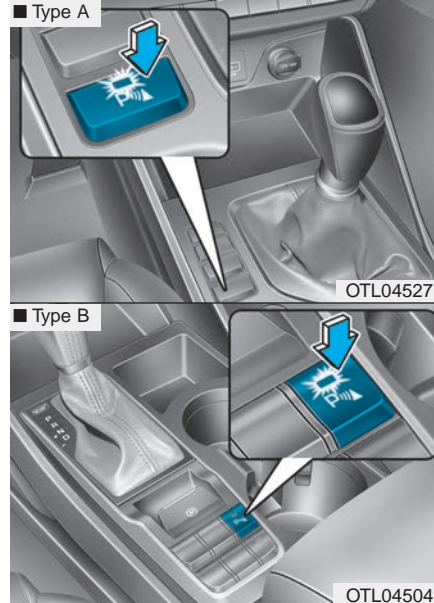







### Operating condition

- This system will activate when the Parking Distance Warning (Reverse/Forward) system button is pressed with the engine running.
- The Parking Distance Warning (Reverse/Forward) system turns on automatically and activates the Parking Distance Warning (Reverse/Forward) system when you move the shift lever to the R (Reverse) position. However, if vehicle speed exceeds 10 km/h (6 mph), the system will not warn you even though objects are detected, and if vehicle speed exceeds 20 km/h (12 mph), the system will turn off automatically. To turn on the system, press the Parking Distance Warning (Reverse/Forward) system button.
- When more than two objects are sensed at the same time, the closest one will be recognized first.



Types of warning sound and indicator

cm (in)

Distance from object		Warning indicator		Warning sound
		When driving forward	When driving rearward	
61 ~ 100 (24 ~ 39)	Front		-	Buzzer beeps intermittently
61 ~ 120 (24 ~ 47)	Rear	-		Buzzer beeps intermittently
31 ~ 60 (12 ~ 24)	Front			Buzzer beeps frequently
	Rear	-		Buzzer beeps frequently
30 (12)	Front			Buzzer sounds continuously
	Rear	-		Buzzer sounds continuously

**NOTICE**

- The indicator may differ from the illustration depending on objects or sensors status. If the indicator blinks, we recommend that the system be checked by an authorized HYUNDAI dealer.
- If the audible warning does not sound or if the buzzer sounds intermittently when shifting into R (Reverse) position, this may indicate a malfunction with the Parking Distance Warning (Reverse/Forward) system. If this occurs, we recommend that you have your vehicle checked by an authorized HYUNDAI dealer as soon as possible.

**Non-operational conditions of Parking Distance Warning (Reverse/Forward) system**

Parking Distance Warning (Reverse/Forward) system may not operate normally when:

- Moisture is frozen to the sensor.
- Sensor is covered with foreign matter, such as snow or water, or the sensor cover is blocked.

**There is a possibility of Parking Distance Warning (Reverse/Forward) system malfunction when:**

- Driving on uneven road surfaces such as unpaved roads, gravel, bumps, or gradient.
- Objects generating excessive noise such as vehicle horns, loud motorcycle engines, or truck air brakes can interfere with the sensor.
- Heavy rain or water spray is present.
- Wireless transmitters or mobile phones are present near the sensor.
- The sensor is covered with snow.
- Any non-factory equipment or accessories have been installed, or if the vehicle bumper height or sensor installation has been modified.

**Detecting range may decrease when:**

- Outside air temperature is extremely hot or cold.
- Undetectable objects smaller than 1 m and narrower than 14 cm in diameter.

**The following objects may not be recognized by the sensor:**

- Sharp or slim objects such as ropes, chains or small poles.
- Objects, which tend to absorb sensor frequency such as clothes, spongy material or snow.

**⚠ WARNING**

**Your new vehicle warranty does not cover any accidents or damage to the vehicle or injuries to its occupants related to a Parking Distance Warning (Reverse/Forward) system. Always drive safely and cautiously.**

***Parking Distance Warning (Reverse/Forward) system precautions***

- The Parking Distance Warning (Reverse/Forward) system may not sound consistently depending on the speed and shapes of the objects detected.
- The Parking Distance Warning (Reverse/Forward) system may malfunction if the vehicle bumper height or sensor installation has been modified or damaged. Any non-factory installed equipment or accessories may also interfere with the sensor performance.
- The sensor may not recognize objects less than 30 cm (11 in.) from the sensor, or it may sense an incorrect distance. Use caution.
- When the sensor is frozen or stained with snow, dirt, or water, the sensor may be inoperative until the stains are removed using a soft cloth.

- Do not push, scratch or strike the sensor. Sensor damage could occur.
- Do not spray the sensors or its surrounding area directly with a high pressure washer. Shock applied from high pressure water may cause the device to not operate normally.

## Rear View Monitor (if equipped)

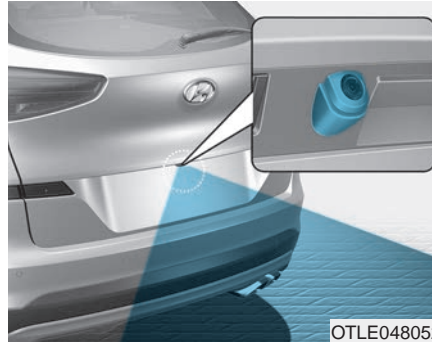
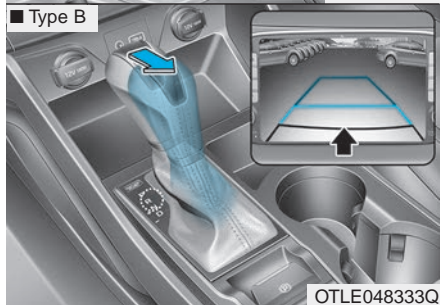
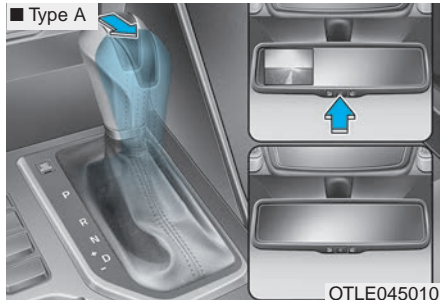

The Rear View Monitor will activate when the engine is running and the shift lever is in the R (Reverse) position.

This is a supplemental system that shows behind the vehicle through the mirror or A/V display while backing-up.

### ■ Type A

The rear view monitor can be turned off by pressing the ON/OFF button when the rear view monitor is activated. Press the ON/OFF button once more to turn on the rear view monitor when the engine is running and the shift lever is in R (Reverse).

### ⚠ WARNING

**The rear camera display is not a safety device. It only serves to assist the driver in identifying objects directly behind the middle of the vehicle. The camera does NOT cover the complete area behind the vehicle.**

### NOTICE

**Do not spray the camera or its surrounding area directly with a high pressure washer. Shock applied from high pressure water may cause the device to not operate normally.**

## ⚠ WARNING

- Never rely solely on the rear camera display when backing-up.
- ALWAYS look around your vehicle to make sure there are no objects or obstacles before moving the vehicle in any direction to prevent a collision.
- Always pay close attention when the vehicle is driven close to objects, particularly pedestrians, and especially children.

### **i** Information

Always keep the camera lens clean. The camera may not work normally if the lens is covered with foreign material.

## Surround View Monitor (if equipped)

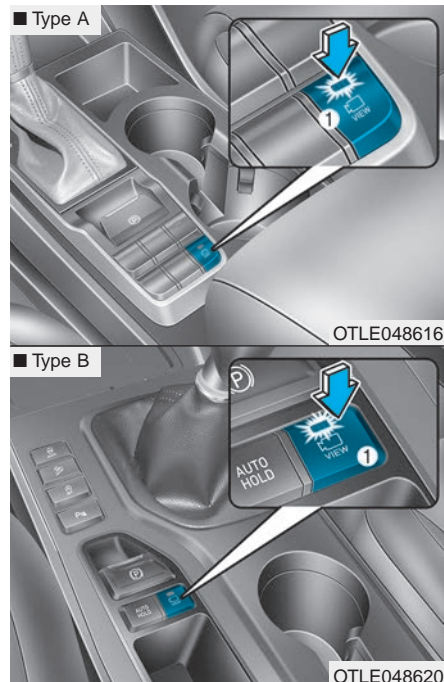

The Surround View Monitor system can assist in parking by allowing the driver to see around the vehicle.

Push the button (1, indicator ON) to operate the system. To cancel the system, push the button again (1, indicator OFF).

### **Operating conditions**

- When the Engine Start/Stop button is in the ON position
- When the transmission is in D, N or R
- When vehicle speed is under 15 km/h

### **i** Information

- When vehicle speed is over 15km/h, the system will turn off. The system will not automatically turn on again, even though vehicle speed gets below 15 km/h. Push the button (1, indicator ON) again, to turn on the system.
- When the vehicle is backing up, the system will turn ON regardless of vehicle speed or button status. However, if vehicle speed is over 15 km/h when driving forward, the SVM system will turn off.

- A warning appears on the system when:
  - The tailgate is opened
  - The driver's door is opened
  - The passenger's door is opened
  - The outside rearview mirror is folded
- If the system is not operating normally, we recommend that you take your vehicle to an authorized HYUNDAI dealer and have the system checked.

For more details, refer to the separately supplied manual with your vehicle.

**CAUTION**



(1) Front camera  
(2) Left/Right camera  
(3) Rear camera

ODH047435

**Surround View Monitor system only serves to assist the driver in parking. ALWAYS look around your vehicle to make sure there are no objects or obstacles before moving the vehicle.**

**NOTICE**

Always keep the camera lens clean. The camera may not work normally if the lens is covered with foreign material.

## DEFROSTER

### NOTICE

To prevent damage to the conductors bonded to the inside surface of the rear window, never use sharp instruments or window cleaners containing abrasives to clean the window.

### **i** Information

If you want to defrost and defog the front windshield, refer to “Windshield Defrosting and Defogging” in this chapter.

### Rear window defroster

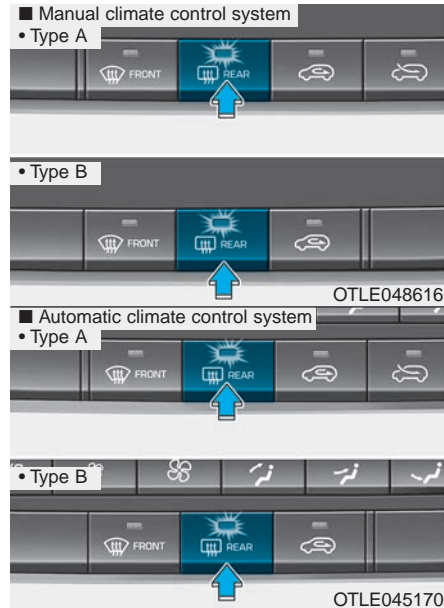

The defroster heats the window to remove frost, fog and thin ice from the interior and exterior of the rear window, while engine is running.

- To activate the rear window defroster, press the rear window defroster button located in the center facia switch panel. The indicator on the rear window defroster button illuminates when the defroster is ON.
- To turn off the defroster, press the rear window defroster button again.

### **i** Information

- If there is heavy accumulation of snow on the rear window, brush it off before operating the rear defroster.
- The rear window defroster automatically turns off after approximately 20 minutes or when the Engine Start/Stop button is in the OFF position.

### *Outside mirror defroster (if equipped)*

If your vehicle is equipped with the outside mirror defrosters, they will operate at the same time you turn on the rear window defroster.

## MANUAL CLIMATE CONTROL SYSTEM (IF EQUIPPED)

### ■ Type A



1. Fan speed control knob
  2. Temperature control knob
  3. Mode selection buttons
  4. Front windshield defroster button
  5. Rear window defroster button
  6. Air intake control button
  7. A/C (Air conditioning) button\*
- \* : if equipped

### ■ Type B



## Heating and air conditioning

1. Start the engine.
2. Set the mode to the desired position.

To improve the effectiveness of heating and cooling :

- Heating: 

- Cooling: 

3. Set the temperature control to the desired position.
4. Set the air intake control to the outside (fresh) air position.
5. Set the fan speed control to the desired speed.
6. If air conditioning is desired, turn the air conditioning system on.

## Mode selection

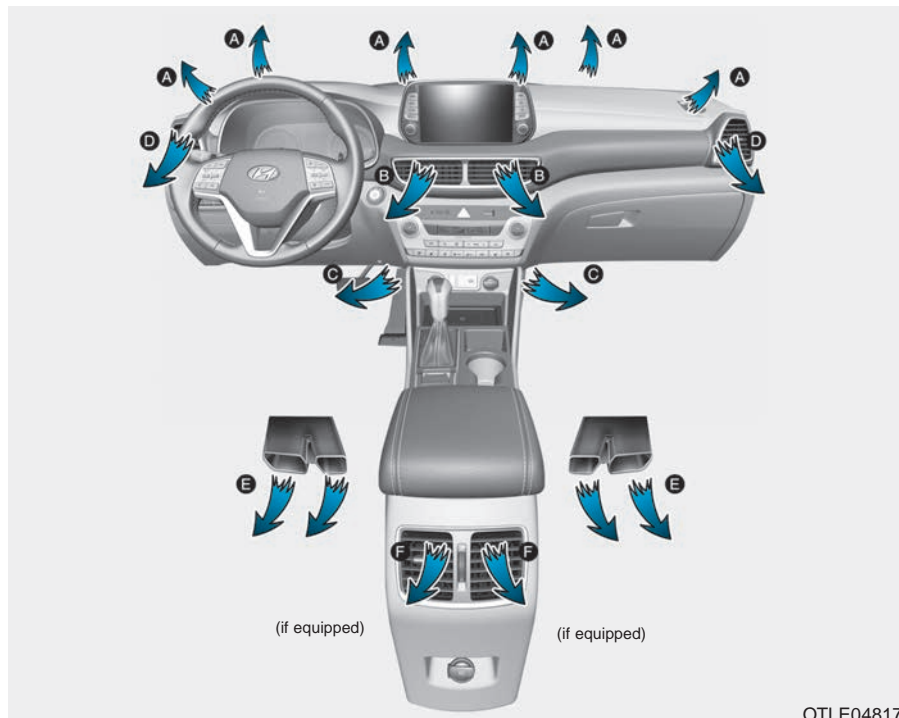

OTLE048173

The mode selection button controls the direction of the air flow through the ventilation system.

Air can be directed to the floor, dashboard outlets, or windshield.



### Defrost-Level (A, D)

Most of the air flow is directed to the windshield.









### Face-Level (B, D, F)

Air flow is directed toward the upper body and face. Additionally, each outlet can be controlled to direct the air discharged from the outlet.

### Floor-Level (A, C, D, E, F)

Most of the air flow is directed to the floor.

Also you may select 2~3 modes at the same time.

- face (  ) + floor (  ) mode
- face (  ) + defrost (  ) mode
- floor (  ) + defrost (  ) mode
- face (  ) + floor (  ) + defrost (  ) mode

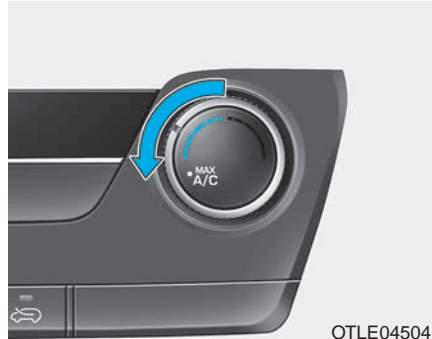

### MAX A/C-Level (B, D, F) (if equipped)

To operate the MAX A/C, turn the mode selection knob to extreme left. Air flow is directed toward the upper body and face.

In this mode, the air conditioning and the recirculated air position will be selected automatically.

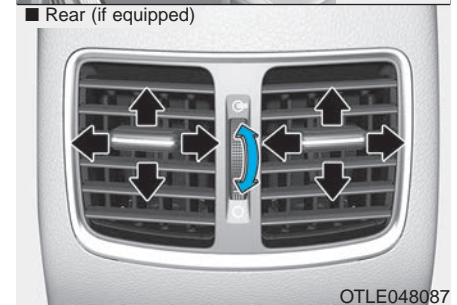
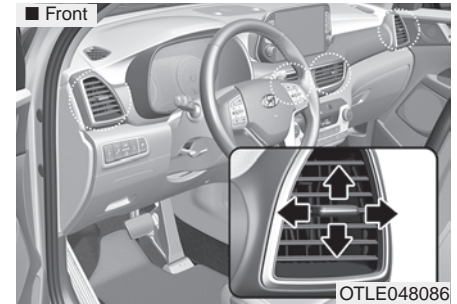

### Instrument panel vents

The instrument panel vent air flow can be directed up/down or left/right using the vent adjustment lever.

**Front :**

The outlet vents can be opened or closed separately using the vent control lever. To close the vent completely, move the vent control lever all the way to the left. You will hear a click.

**Rear :**

The outlet vents can be opened (☼) or closed (○) separately using the thumbwheel.

**Temperature control (if equipped)**



The temperature control knob allows you to control the temperature of the air flowing from the ventilation system. To change the air temperature in the passenger compartment, turn the knob to the right position for warm and hot air or left position for cooler air.

**Air intake control**

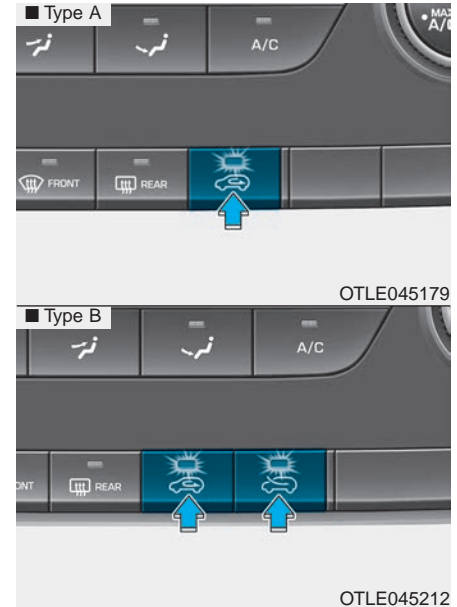

This is used to select outside (fresh) air position or recirculated air position. To change the air intake control position, press the control button.

### Recirculated air position



With the recirculated air position selected, air from the passenger compartment will be drawn through the heating system and heated or cooled according to the function selected.

### Outside (fresh) air position

■ Type A



■ Type B



With the outside (fresh) air position selected, air enters the vehicle from outside and is heated or cooled according to the function selected.

### **i** Information

It should be noted that prolonged operation of the heater in the recirculated air position (without air conditioning selected) will cause fogging of the windshield and side windows and the air within the passenger compartment will become stale.

In addition, prolonged use of the air conditioning with the recirculated air position selected will result in excessively dry air in the passenger compartment.

### **⚠** WARNING

- **Continuous operation of the climate control system in the recirculated air position may allow humidity to increase inside the vehicle which may fog the glass and obscure visibility.**
- **Do not sleep in a vehicle with air conditioning or heating system on. It may cause serious harm or death due to a drop in the oxygen level and/or body temperature.**
- **Continuous operation of the climate control system in the recirculated air position can cause drowsiness or sleepiness, and loss of vehicle control. Set the air intake control to the outside (fresh) air position as much as possible while driving.**

### *Fan speed control*



The ignition switch must be in the ON position for fan operation.

The fan speed control knob allows you to control the fan speed of the air flowing from the ventilation system. To change the fan speed, turn the knob to the right for higher speed or left for lower speed.



OTLE045211

### To turn off the fan

To turn off the fan, turn the fan speed control knob to the "0" position.

### NOTICE

Operating the fan speed when the ignition switch is in the ON position could cause the battery to discharge. Operate the fan speed when the engine is running.

### Air conditioning (A/C) (if equipped)



OTLE045290

Press the A/C button to turn the air conditioning system on (indicator light will illuminate). Press the button again to turn the air conditioning system off.

## System operation

### Ventilation

1. Set the mode to the position.
2. Set the air intake control to the outside (fresh) air position.
3. Set the temperature control to the desired position.
4. Set the fan speed control to the desired speed.

### Heating

1. Set the mode to the position.
2. Set the air intake control to the outside (fresh) air position.
3. Set the temperature control to the desired position.
4. Set the fan speed control to the desired speed.
5. If dehumidified heating is desired, turn the air conditioning system on. (if equipped)

If the windshield fogs up, set the mode to the or position.

### Operation Tips

- To keep dust or unpleasant fumes from entering the car through the ventilation system, temporarily set the air intake control to the recirculated air position. Be sure to return the control to the fresh air position when the irritation has passed to keep fresh air in the vehicle. This will help keep the driver alert and comfortable.
- Air for the heating/cooling system is drawn in through the grilles just ahead of the windshield. Care should be taken that these are not blocked by leaves, snow, ice or other obstructions.
- To prevent interior fog on the windshield, set the air intake control to the fresh air position and fan speed to the desired position, turn on the air conditioning system, and adjust the temperature control to desired temperature.

### Air conditioning

HYUNDAI Air Conditioning Systems are filled with R-134a or R-1234yf refrigerant.

1. Start the engine. Push the air conditioning button.
2. Set the mode to the  position.
3. Set the air intake control to the outside air or recirculated air position.
4. Adjust the fan speed control and temperature control to maintain maximum comfort.

### Information

**Your vehicle is filled with R-134a or R-1234yf according to the regulation in your country at the time of production. You can find out which air conditioning refrigerant is applied to your vehicle on the label located inside of the hood. Refer to chapter 8 for the location of the air conditioning refrigerant label.**

### NOTICE

- **The refrigerant system should only be serviced by trained and certified technicians to insure proper and safe operation.**
- **The refrigerant system should be serviced in a well-ventilated place.**
- **The air conditioning evaporator (cooling coil) shall never be repaired or replaced with one removed from a used or salvaged vehicle and new replacement MAC evaporators shall be certified (and labeled) as meeting SAE Standard J2842.**

## **i** Information

- When using the air conditioning system, monitor the temperature gauge closely while driving up hills or in heavy traffic when outside temperatures are high. Air conditioning system operation may cause engine overheating. Continue to use the blower fan but turn the air conditioning system off if the temperature gauge indicates engine overheating.
- When opening the windows in humid weather air conditioning may create water droplets inside the vehicle. Since excessive water droplets may cause damage to electrical equipment, air conditioning should only be used with the windows closed.

## **Air conditioning system operation tips**

- If the vehicle has been parked in direct sunlight during hot weather, open the windows for a short time to let the hot air inside the vehicle escape.
  - To help reduce moisture inside of the windows on rainy or humid days, decrease the humidity inside the vehicle by operating the air conditioning system.
  - During air conditioning system operation, you may occasionally notice a slight change in engine speed as the air conditioning compressor cycles. This is a normal system operation characteristic.
  - Use the air conditioning system every month only for a few minutes to ensure maximum system performance.
  - When using the air conditioning system, you may notice clear water dripping (or even puddling) on the ground under the passenger side of the vehicle. This is a normal system operation characteristic.
- Operating the air conditioning system in the recirculated air position provides maximum cooling, however, continual operation in this mode may cause the air inside the vehicle to become stale.
  - During cooling operation, you may occasionally notice a misty air flow because of rapid cooling and humid air intake. This is a normal system operation characteristic.

## System maintenance

### Climate control air filter

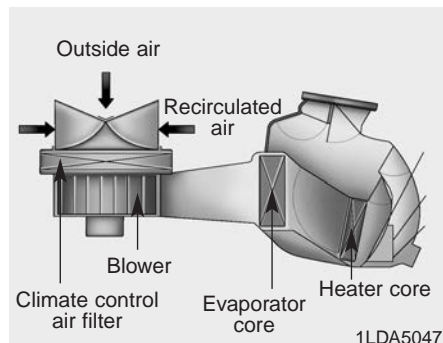

The climate control air filter installed behind the glove box filters the dust or other pollutants that come into the vehicle from the outside through the heating and air conditioning system. If dust or other pollutants accumulate in the filter over a period of time, the air flow from the air vents may decrease, resulting in moisture accumulation on the inside of the windshield even when the outside (fresh) air position is selected. If this happens, we recommend that the climate control air filter be replaced by an authorized HYUNDAI dealer.

### **i** Information

- Replace the filter according to the Maintenance Schedule.

If the car is being driven in severe conditions such as dusty, rough roads, more frequent climate control air filter inspections and changes are required.

- When the air flow rate suddenly decreases, we recommend that the system be checked by an authorized HYUNDAI dealer.

### **NOTICE**

It is important that the correct type and amount of oil and refrigerant is used. Otherwise, damage to the compressor and abnormal system operation may occur.

### **⚠ WARNING**

**We recommend that the air conditioning system be serviced by an authorized HYUNDAI dealer.**

**Improper service may cause serious injury to the person performing the service.**

### Air conditioning refrigerant label



The actual Air Conditioning refrigerant label in the vehicle may differ from the illustration.

Each symbols and specification on air conditioning refrigerant label means as below:

1. Classification of refrigerant
2. Amount of refrigerant
3. Classification of Compressor lubricant

You can find out which air conditioning refrigerant is applied to your vehicle on the label located inside of the hood.

Refer to chapter 8 for the location of the air conditioning refrigerant label.

### ***Checking the amount of air conditioner refrigerant and compressor lubricant***

When the amount of refrigerant is low, the performance of the air conditioning is reduced. Overfilling also has a bad influence on the air conditioning system.

Therefore, if abnormal operation is found, we recommend that the system be inspected by an authorized HYUNDAI dealer.

#### **⚠ WARNING**

**Vehicles equipped with R-134a**



**Because the refrigerant is at very high pressure, the air conditioning system should only be serviced by trained and certified technicians. It is important that the correct type and amount of oil and refrigerant is used.**

**Otherwise, it may cause damage to the vehicle and personal injury.**

#### **⚠ WARNING**

**Vehicles equipped with R-1234yf**



**Because the refrigerant is mildly flammable at very high pressure, the air conditioning system should only be serviced by trained and certified technicians. It is important that the correct type and amount of oil and refrigerant is used.**

**Otherwise, it may cause damage to the vehicle and personal injury.**

We recommend the air conditioning system be serviced by an authorized HYUNDAI dealer.



## AUTOMATIC CLIMATE CONTROL SYSTEM (IF EQUIPPED)

### ■ Type A



1. Driver's temperature control knob
2. Passenger's temperature control knob
3. AUTO (automatic control) button
4. SYNC button
5. OFF button
6. Air conditioning button
7. Fan speed control button
8. Mode selection button
9. Front windshield defrost button
10. Rear window defrost button
11. Air intake control button
12. Climate control information screen

### ■ Type B



## Automatic heating and air conditioning



1. Press the AUTO button.

The modes, fan speeds, air intake and air-conditioning will be controlled automatically according to the temperature setting.

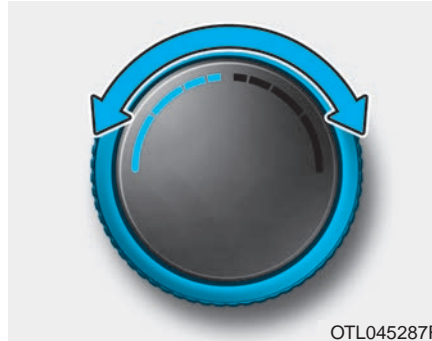

2. Turn the temperature control knob to set the desired temperature.

### **i** Information

- To turn the automatic operation off, select any button of the following:
  - Mode selection button
  - Front windshield defrost button (Press the button one more time to deselect the front windshield defroster function. The 'AUTO' sign will illuminate on the information display once again.)
  - Fan speed control button
- The selected function will be controlled manually while other functions operate automatically.
- For your convenience, use the AUTO button and set the temperature to 23°C (73°F).





### **i** Information

**Never place anything near the sensor to ensure better control of the heating and cooling system.**

### Manual heating and air conditioning

The heating and cooling system can be controlled manually by pushing buttons other than the AUTO button. In this case, the system works sequentially according to the order of buttons selected. When pressing any button except the AUTO button while using automatic operation, the functions not selected will be controlled automatically.

1. Start the engine.
2. Set the mode to the desired position.  
For improving the effectiveness of heating and cooling;
  - Heating: 
  - Cooling: 
3. Set the temperature control to the desired position.

4. Set the air intake control to the outside (fresh) air position.
5. Set the fan speed control to the desired speed.
6. If air conditioning is desired, turn the air conditioning system on.  
Press the AUTO button in order to convert to full automatic control of the system.

## Mode selection

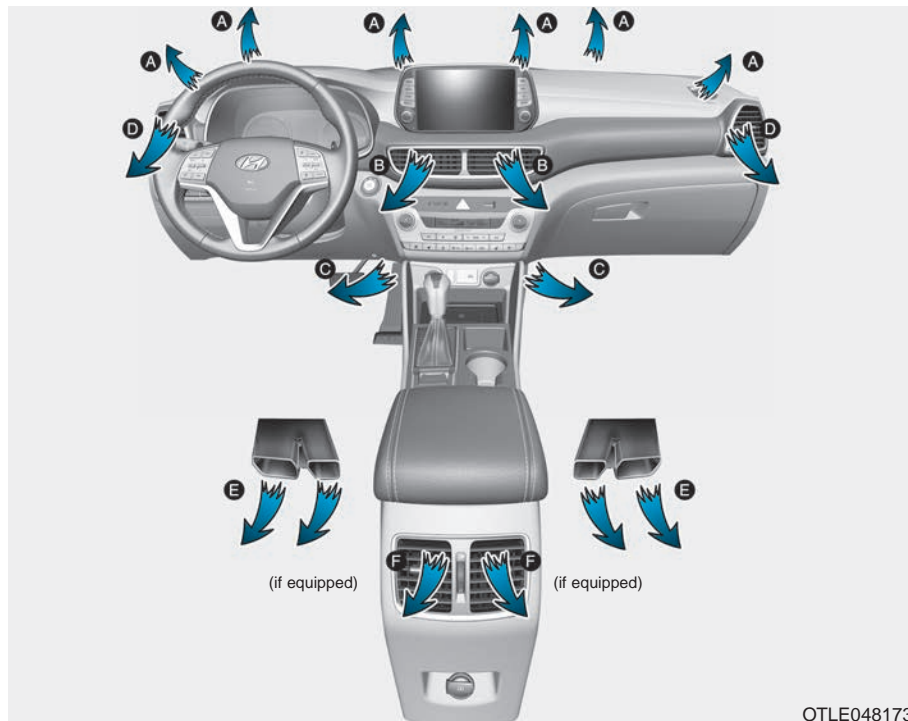

OTLE048173

The mode selection button controls the direction of the air flow through the ventilation system.

 Defrost-Level (A, D)

Most of the air flow is directed to the windshield.

 Face-Level (B, D, F)

Air flow is directed toward the upper body and face. Additionally, each outlet can be controlled to direct the air discharged from the outlet.

 Floor-Level (A, C, D, E, F)

Most of the air flow is directed to the floor.

Also you may select 2~3 modes at the same time.

- face (فرد) + floor (فرد) mode
- face (فرد) + defrost (فرد) mode
- floor (فرد) + defrost (فرد) mode
- face (فرد) + floor (فرد) + defrost (فرد) mode



### Defrost-Level (A)

Most of the air flow is directed to the windshield with a small amount of air directed to the side window defrosters.

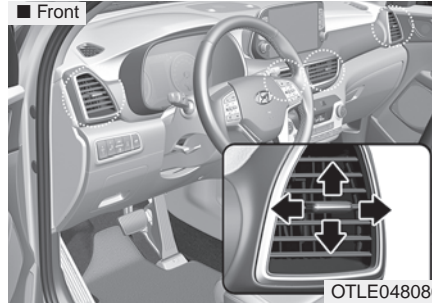

### Rear (if equipped)

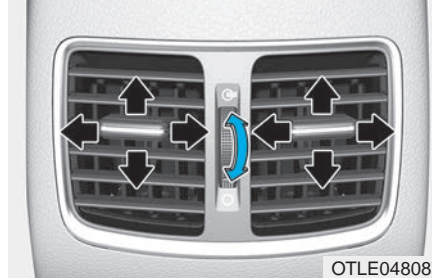

### Instrument panel vents

The instrument panel vent air flow can be directed up/down or left/right using the vent adjustment lever.

### Front :

The outlet vents can be opened or closed separately using the vent control lever. To close the vent completely, move the vent control lever all the way to the left. You will hear a click.

### Rear :

The outlet vents can be opened (☼) or closed (○) separately using the thumbwheel.

## Temperature control



OTL045287R

Turn the temperature control knob to set the desired temperature.



OTLE045218

### Adjusting the driver and passenger side temperature equally

- Press the “SYNC” button to adjust the driver and passenger side temperature equally.

The passenger side temperature will be set to the same temperature as the driver side temperature.

- Turn the driver side temperature control knob. The driver and passenger side temperature will be adjusted equally.

### Adjusting the driver and passenger side temperature individually

- Press the “SYNC” button again to adjust the driver and passenger side temperature individually. The illumination of button turns off.
- Operate the driver side temperature control knob to adjust the driver side temperature.
- Operate the passenger side temperature control knob to adjust the passenger side temperature.

### Temperature conversion

If the battery has been discharged or disconnected, the temperature mode display will reset to Centigrade.

This is a normal condition. You can switch the temperature mode between Centigrade to Fahrenheit as follows;

- Automatic climate control system  
While pressing the OFF button, press the AUTO button for 3 seconds or more. The display will change from Centigrade to Fahrenheit, or from Fahrenheit to Centigrade.
- “User Settings mode” in the cluster :  
You can change the temperature unit in the “Other features → Temperature unit”

### Air intake control



This is used to select the outside (fresh) air position or recirculated air position.

To change the air intake control position, push the control button.

### Recirculated air position



With the recirculated air position selected, air from the passenger compartment will be drawn through the heating system and heated or cooled according to the function selected.

### Outside (fresh) air position

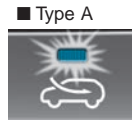

With the outside (fresh) air position selected, air enters the vehicle from outside and is heated or cooled according to the function selected.

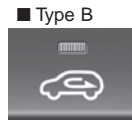

### **i** Information

**Prolonged operation of the heater in the recirculated air position (without air conditioning selected) may cause fogging of the windshield and side windows and the air within the passenger compartment may become stale.**

**In addition, prolonged use of the air conditioning with the recirculated air position selected will result in excessively dry air in the passenger compartment.**

## ⚠ WARNING

- Continued climate control system operation in the recirculated air position may allow humidity to increase inside the vehicle which may fog the glass and obscure visibility.
- Do not sleep in a vehicle with the air conditioning or heating system on. It may cause serious harm or death due to a drop in the oxygen level and/or body temperature.
- Continued climate control system operation in the recirculated air position can cause drowsiness or sleepiness, and loss of vehicle control. Set the air intake control to the outside (fresh) air position as much as possible while driving.

### Fan speed control

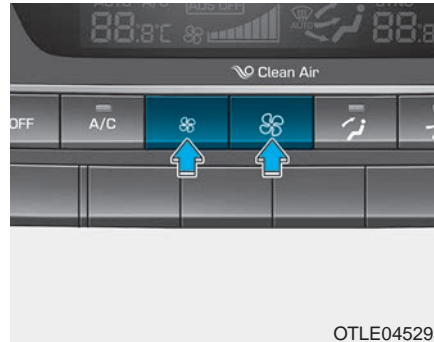

The fan speed can be set to the desired speed by pushing the fan speed control button.

The higher the fan speed is, the more air is delivered.

Pressing the OFF button turns off the fan.

### NOTICE

Operating the fan speed when the ignition switch is in the ON position could cause the battery to discharge. Operate the fan speed when the engine is running.

### Air conditioning



Push the A/C button to turn the air conditioning system on (indicator light will illuminate).

Push the button again to turn the air conditioning system off.



### OFF mode





Push the OFF button of the front to turn off the air climate control system. However, you can still operate the mode and air intake buttons as long as the ignition switch is in the ON position.

### System operation

#### Ventilation

1. Set the mode to the  position.
2. Set the air intake control to the outside (fresh) air position.
3. Set the temperature control to the desired position.
4. Set the fan speed control to the desired speed.

#### Heating

1. Set the mode to the  position.
  2. Set the air intake control to the outside (fresh) air position.
  3. Set the temperature control to the desired position.
  4. Set the fan speed control to the desired speed.
  5. If dehumidified heating is desired, turn the air conditioning system on.
- If the windshield fogs up, set the mode to the  or  position.

### Operation Tips

- To keep dust or unpleasant fumes from entering the vehicle through the ventilation system, temporarily set the air intake control to the recirculated air position. Be sure to return the control to the fresh air position when the irritation has passed to keep fresh air in the vehicle. This will help keep the driver alert and comfortable.
- Air for the heating/cooling system is drawn in through the grilles just ahead of the windshield. Care should be taken that these are not blocked by leaves, snow, ice or other obstructions.
- To prevent interior fog on the windshield, set the air intake control to the fresh air position and fan speed to the desired position, turn on the air conditioning system, and adjust the temperature control to desired temperature.

## Air conditioning

HYUNDAI Air Conditioning Systems are filled with R-134a or R-1234yf refrigerant.

1. Start the engine. Push the air conditioning button.
2. Set the mode to the  position.
3. Set the air intake control to the outside air or recirculated air position.
4. Adjust the fan speed control and temperature control to maintain maximum comfort.

### Information

Your vehicle is filled with R-134a or R-1234yf according to the regulation in your country at the time of production. You can find out which air conditioning refrigerant is applied to your vehicle on the label located inside of the hood. Refer to chapter 8 for the location of the air conditioning refrigerant label.

### NOTICE

- The refrigerant system should only be serviced by trained and certified technicians to insure proper and safe operation.
- The refrigerant system should be serviced in a well-ventilated place.
- The air conditioning evaporator (cooling coil) shall never be repaired or replaced with one removed from a used or salvaged vehicle and new replacement MAC evaporators shall be certified (and labeled) as meeting SAE Standard J2842.

### Information

- When using the air conditioning system, monitor the temperature gauge closely while driving up hills or in heavy traffic when outside temperatures are high. Air conditioning system operation may cause engine overheating. Continue to use the blower fan but turn the air conditioning system off if the temperature gauge indicates engine overheating.
- When opening the windows in humid weather air conditioning may create water droplets inside the vehicle. Since excessive water droplets may cause damage to electrical equipment, air conditioning should only be used with the windows closed.

### Air conditioning system operation tips

- If the vehicle has been parked in direct sunlight during hot weather, open the windows for a short time to let the hot air inside the vehicle escape.
- Use air conditioning to reduce humidity and moisture inside the vehicle on rainy or humid days.
- During air conditioning system operation, you may occasionally notice a slight change in engine speed as the air conditioning compressor cycles. This is a normal system operation characteristic.
- Use the air conditioning system every month only for a few minutes to ensure maximum system performance.
- When using the air conditioning system, you may notice clear water dripping (or even puddling) on the ground under the passenger side of the vehicle. This is a normal system operation characteristic.

- Operating the air conditioning system in the recirculated air position provides maximum cooling, however, continual operation in this mode may cause the air inside the vehicle to become stale.
- During cooling operation, you may occasionally notice a misty air flow because of rapid cooling and humid air intake. This is a normal system operation characteristic.

### System maintenance

#### Climate control air filter

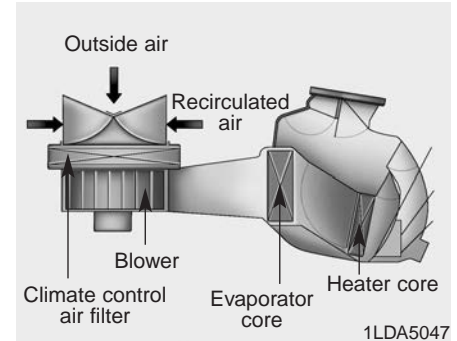

The climate control air filter installed behind the glove box filters the dust or other pollutants that come into the vehicle from the outside through the heating and air conditioning system. If dust or other pollutants accumulate in the filter over a period of time, the air flow from the air vents may decrease, resulting in moisture accumulation on the inside of the windshield even when the outside (fresh) air position is selected. If this happens, we recommend that the climate control air filter be replaced by an authorized HYUNDAI dealer.

**i Information**

- Replace the filter according to the Maintenance Schedule.

If the car is being driven in severe conditions such as dusty, rough roads, more frequent climate control air filter inspections and changes are required.

- When the air flow rate suddenly decreases, we recommend that the system be checked by an authorized HYUNDAI dealer.

**Air Conditioning refrigerant label**



The actual Air Conditioning refrigerant label in the vehicle may differ from the illustration.

Each symbols and specification on air conditioning refrigerant label means as below:

1. Classification of refrigerant
2. Amount of refrigerant
3. Classification of Compressor lubricant

You can find out which air conditioning refrigerant is applied to your vehicle on the label located inside of the hood.

Refer to chapter 8 for the location of the air conditioning refrigerant label.

**Checking the amount of air conditioner refrigerant and compressor lubricant**

When the amount of refrigerant is low, the performance of the air conditioning is reduced. Overfilling also has a bad influence on the air conditioning system.

Therefore, if abnormal operation is found, we recommend that the system be inspected by an authorized HYUNDAI dealer.

**⚠ WARNING**

Vehicles equipped with R-134a



Because the refrigerant is at very high pressure, the air conditioning system should only be serviced by trained and certified technicians. It is important that the correct type and amount of oil and refrigerant is used.

Otherwise, it may cause damage to the vehicle and personal injury.

**⚠ WARNING**

Vehicles equipped with R-1234yf



Because the refrigerant is mildly inflammable at very high pressure, the air conditioning system should only be serviced by trained and certified technicians. It is important that the correct type and amount of oil and refrigerant is used.



Otherwise, it may cause damage to the vehicle and personal injury.

We recommend the air conditioning system be serviced by an authorized HYUNDAI dealer.

## WINDSHIELD DEFROSTING AND DEFOGGING

### ⚠ WARNING

#### Windshield heating



Do not use the  or  position during cooling operation in extremely humid weather. The difference between the temperature of the outside air and that of the windshield could cause the outer surface of the windshield to fog up, causing loss of visibility. In this case, set the mode selection knob or button to the  position and fan speed control knob or button to lower speed.

- For maximum defrosting, set the temperature control to the extreme right/hot position and the fan speed control to the highest speed.
- If warm air to the floor is desired while defrosting or defogging, set the mode to the floor-defrost position.
- Before driving, clear all snow and ice from the windshield, rear window, outside rear view mirrors, and all side windows.
- Clear all snow and ice from the hood and air inlet in the cowl grill to improve heater and defroster efficiency and to reduce the probability of fogging up inside of the windshield.

## Manual climate control system

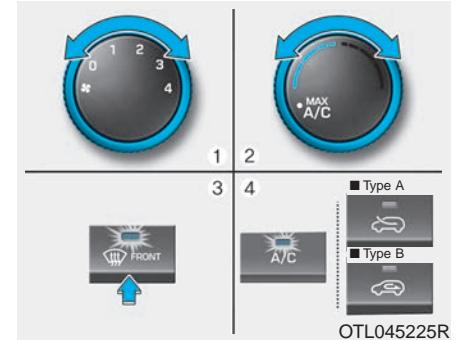
### To defog inside windshield



1. Select any fan speed except “0” position.
2. Select desired temperature.
3. Select the  or  position.
4. The outside (fresh) air will be selected automatically. Additionally, the air conditioning (if equipped) will automatically operate if the mode is selected to the  position.

If the air conditioning and outside (fresh) air position are not selected automatically, press the corresponding button manually.

### To defrost outside windshield

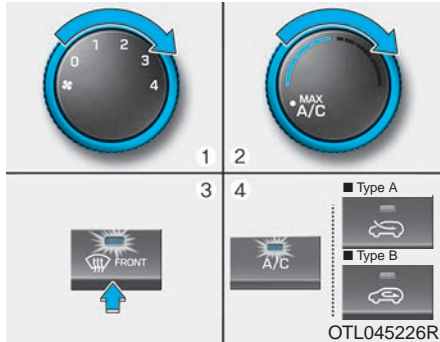

1. Set the fan speed to the highest (extreme right) position.
2. Set the temperature to the extreme hot position.
3. Select the position.
4. The outside (fresh) air and air conditioning (if equipped) will be selected automatically.

### Automatic climate control system

#### To defog inside windshield

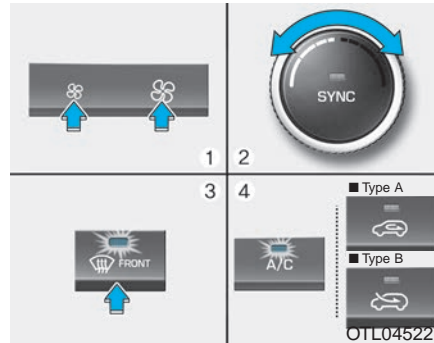

1. Select desired fan speed.
2. Select desired temperature.
3. Press the defroster button ().
4. The air-conditioning will turn on according to the detected ambient temperature, outside (fresh) air position and higher fan speed will be selected automatically.

If the air-conditioning, outside (fresh) air position and higher fan speed are not selected automatically, adjust the corresponding button or knob manually.

If the position is selected, lower fan speed is controlled to higher fan speed.

## To defrost outside windshield

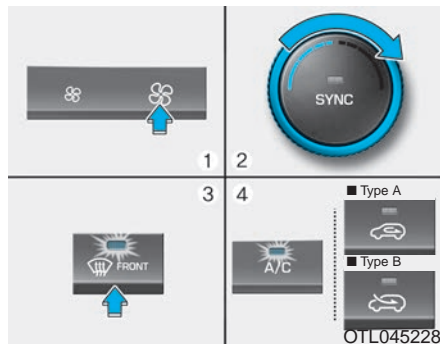

1. Set fan speed to the highest position.
2. Set temperature to the extreme hot (HI) position.
3. Press the defroster button ( ).
4. The air-conditioning will turn on according to the detected ambient temperature and outside (fresh) air position will be selected automatically.

If the position is selected, lower fan speed is controlled to higher fan speed.

## Defogging logic (if equipped)

To reduce the probability of fogging up the inside of the windshield, the air intake or air conditioning are controlled automatically according to certain conditions such as or position. To cancel or return the defogging logic, do the following.

### Manual climate control system

1. Turn the ignition switch to the ON position.
2. Press the defroster button ( ).
3. Press the air intake control button at least 5 times within 3 seconds.

The indicator on the air intake button blinks 3 times with 0.5 seconds of interval. It indicates that the defogging logic is canceled or returned to the programmed status.

If the battery has been discharged or disconnected, it resets to the defog logic status.

### Automatic climate control system

1. Turn the ignition switch to the ON position.
2. Press the defroster button ( ).
3. While pressing the air conditioning button (A/C), press the air intake control button at least 5 times within 3 seconds.

The climate control information screen will blink 3 times with 0.5 seconds of interval. It indicates that the defogging logic is canceled or returned to the programmed status.

If the battery has been discharged or disconnected, it resets to the defog logic status.



### **Auto defogging system (only for automatic climate control system, if equipped)**



Auto defogging reduces the possibility of fogging up the inside of the windshield by automatically sensing the moisture of inside the windshield. The auto defogging system operates when the heater or air conditioning is on.

#### **i Information**

The auto defogging system may not operate normally, when the outside temperature is below -10 °C.



When the Auto Defogging System operates, the indicator will illuminate.

If higher level of moisture are sensed in the vehicle, the Auto Defogging System will operate in the following order:

- Step 1 : Outside air position
- Step 2 : Operating the air conditioning
- Step 3 : Blowing air toward the windshield
- Step 4 : Increasing air flow toward the windshield

If the air conditioning is off or recirculated air position is manually selected while Auto Defogging System is ON, the “ADS OFF” symbol will blink 3 times to signal that the manual operation has been canceled.

### **To cancel or reset the Auto Defogging System**

Press the front windshield defroster button for 3 seconds when the ignition switch is in the ON position. When the Auto Defogging System is canceled, ADS OFF symbol will blink 3 times and the ADS OFF will be displayed on the climate control information screen.

When the Auto Defogging System is reset, ADS OFF symbol will blink 6 times without a signal.

#### **i Information**

- When the air conditioning is turned on by Auto defogging system, if you try to turn off the air conditioning, the indicator will blink 3 times and the air conditioning will not be turned off.
- For efficiency, do not select recirculated air position while Auto defogging system is operating.

#### **NOTICE**

Do not remove the sensor cover located on the upper end of the driver side windshield glass.

Damage to system parts could occur and may not be covered by your vehicle warranty.

## CLIMATE CONTROL ADDITIONAL FEATURES

### Cluster ionizer (Except Europe)

When the ignition switch is in the ON position, the clean air function turns on automatically.

Also, the clean air function turns off automatically, when the ignition switch is in the OFF position.

### Automatic ventilation (if equipped)

When the ignition switch is in the ON position or when the engine is running and temperature is low with the recirculated air position selected more than 5 min ~ 30 min, the air intake position will automatically change to the outside (fresh) air position.

### To cancel or set the Automatic Ventilation

When the air conditioning system is on, select Face Level  mode and press the recirculated air position button more than five times for three seconds while pressing A/C button.

When the automatic ventilation is set, the air intake control button (recirculated air position) indicator will blink 6 times. When canceled, the air intake control button (recirculated air position) indicator will blink 3 times.

### Sunroof inside air recirculation (if equipped)

When the heater or air conditioning system is on with the sunroof opened, the outside (fresh) air position will be automatically selected. At this time, if you press the recirculated air position button, the recirculated air position will be selected but will change back to the outside (fresh) air position after 3 minutes.

When the sunroof is closed, the air intake position will return to the original position that was selected.

## STORAGE COMPARTMENT

### ⚠ WARNING

Never store cigarette lighters, propane cylinders, or other flammable/explosive materials in the vehicle. These items may catch fire and/or explode if the vehicle is exposed to hot temperatures for extended periods.

### ⚠ WARNING

**ALWAYS** keep the storage compartment covers closed securely while driving. Items inside your vehicle are moving as fast as the vehicle. If you have to stop or turn quickly, or if there is a crash, the items may fly out of the compartment and may cause an injury if they strike the driver or a passenger.

### NOTICE

To avoid possible theft, do not leave valuables in the storage compartments.

### Center console storage

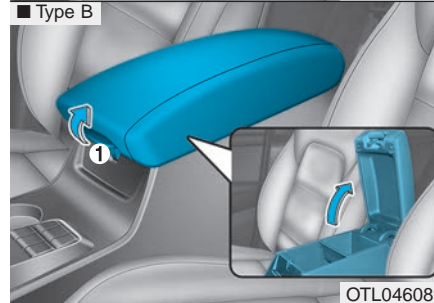
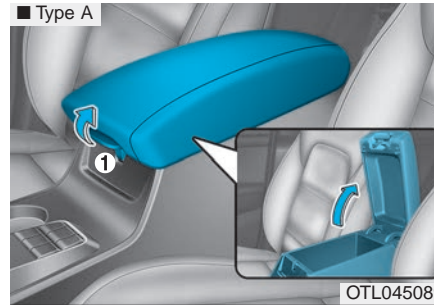

To open :  
Pull the lever (1).

### Sliding armrest (if equipped)

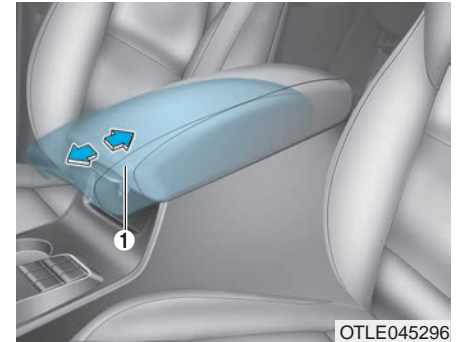

To move the armrest forward:  
Grab the front portion of the armrest (1) then pull it forward.

To move the armrest rearward:  
Push the armrest rearward.

### ⚠ CAUTION

**Do not grab the front portion of the armrest (1) when moving the armrest rearward. You may pinch your fingers.**

## Glove box

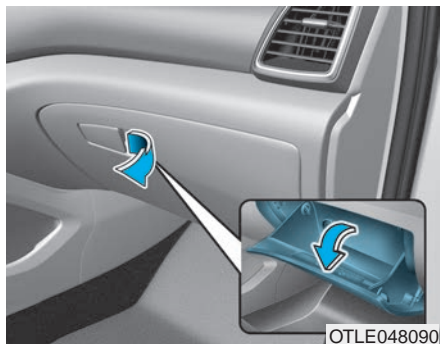

To open the glove box, pull the handle and the glove box will automatically open. Close the glove box after use.

### **⚠ WARNING**

**ALWAYS** close the glove box door after use.

**An open glove box door can cause serious injury to the passenger in an accident, even if the passenger is wearing a seat belt.**

## Cool box (if equipped)

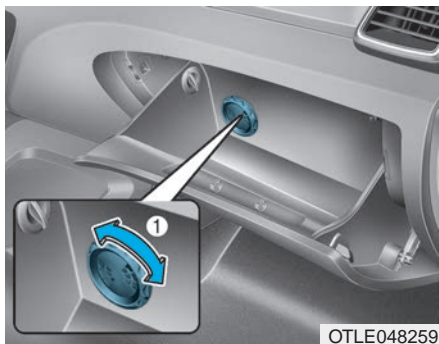

You can keep beverage cans or other items cool in the glove box.

1. Turn on the air conditioning.
2. Slide the open/close lever (1) of the vent installed in the glove box to the open position.
3. When the cool box is not used, slide the lever (1) to the closed position.

### **NOTICE**

**If some items in the cool box block the vent, the cooling effectiveness of the cool box is reduced.**

## Sunglass holder (if equipped)



To open:

Press the cover and the holder will slowly open. Place your sunglasses in the compartment door with the lenses facing out.

To close:

Push back into position.

Make sure the sunglass holder is closed while driving.

### **WARNING**

- **Do not keep objects except sunglasses inside the sunglass holder. Such objects can be thrown from the holder in the event of a sudden stop or an accident, possibly injuring the passengers in the vehicle.**
- **Do not open the sunglass holder while the vehicle is moving. The rear view mirror of the vehicle can be blocked by an open sunglass holder.**
- **Do not put the glasses forcibly into a sunglass holder. It may cause personal injury if you try to open it forcibly when the glasses are jammed in holder.**

## INTERIOR FEATURES

### Ashtray (if equipped)

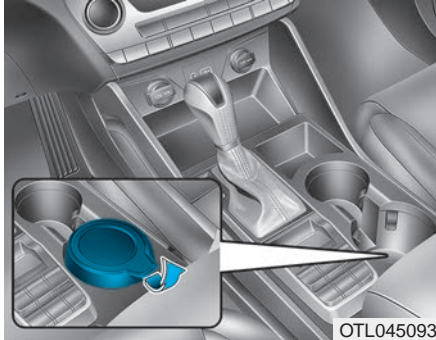

To use the ashtray, open the cover.

To clean the ashtray:

The plastic receptacle should be removed by lifting the plastic ashtray receptacle upward after turning the cover counterclockwise and pulling it out.

#### **WARNING**

**Putting lit cigarettes or matches in an ashtray with other combustible materials may cause a fire.**

### Cup holder

#### Front

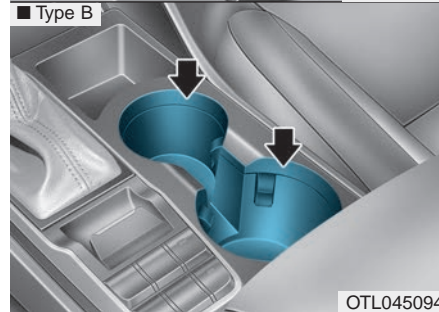
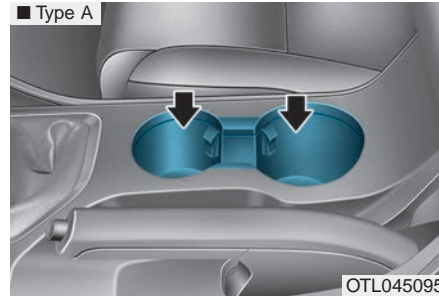

Cups or small beverages cups may be placed in the cup holders.

#### Rear

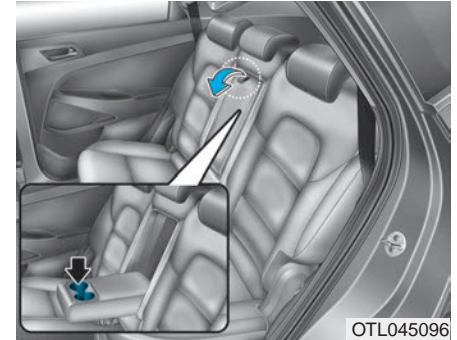

Pull the armrest down to use the cup holders.

### ⚠ WARNING

- Avoid abrupt starting and braking when the cup holder is in use to prevent spilling your drink. If hot liquid spills, you could be burned. Such a burn to the driver could cause loss of vehicle control resulting in an accident.
- Do not place uncovered or unsecured cups, bottles, cans, etc., in the cup holder containing hot liquid while the vehicle is in motion. Injuries may result in the event of sudden stop or collision.
- Only use soft cups in the cup holders. Hard objects can injure you in an accident.

### ⚠ WARNING

Keep cans or bottles out of direct sun light and do not put them in a hot vehicle. It may explode.

### NOTICE

- Keep your drinks sealed while driving to prevent spilling your drink. If liquid spills, it may get into the vehicle's electrical/electronic system and damage electrical/electronic parts.
- When cleaning spilled liquids, do not dry the cup holder at high temperature. This may damage the cup holder.

## Sunvisor

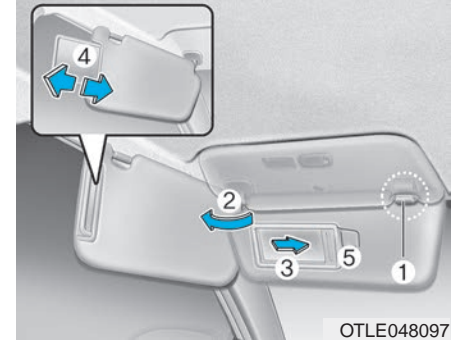

To use a sunvisor, pull it downward. To use a sunvisor for a side window, pull it downward, unsnap it from the bracket (1) and swing it to the side (2). To use the vanity mirror, pull down the sunvisor and slide the mirror cover (3). Adjust the sunvisor forward or backward (4) as needed. Use the ticket holder (5) to hold tickets.

### **i** Information

Close the vanity mirror cover securely and return the sunvisor to its original position after use.



## ⚠ WARNING

For your safety, do not block your view when using the sunvisor.

## NOTICE

- Do not put several tickets in the ticket holder at one time. This could cause damage to the ticket holder.
- Avoid putting a plastic card such as a credit card in the ticket holder located in the outside of the sunvisor. This could cause damage to the plastic card.

## Power outlet (if equipped)

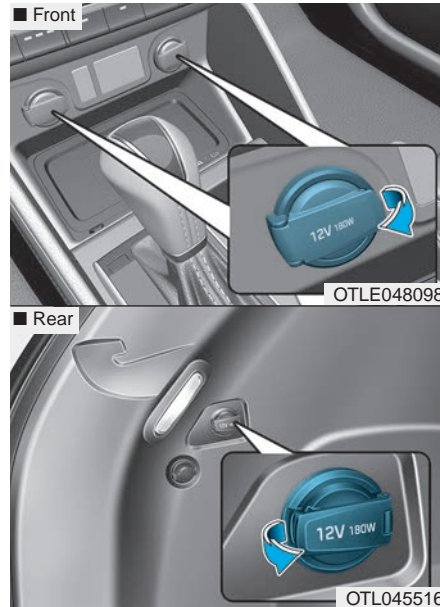

The power outlet is designed to provide power for mobile telephones or other devices designed to operate with vehicle electrical systems. The devices should draw less than 180 W(Watt) with the engine running.

## ⚠ WARNING

Avoid electrical shocks. Do not place your fingers or foreign objects (pin, etc.) into a power outlet or touch the power outlet with a wet hand.

## NOTICE

To prevent damage to the Power Outlets :

- Use the power outlet only when the engine is running and remove the accessory plug after use. Using the accessory plug for prolonged periods of time with the engine off could cause the battery to discharge.
- Only use 12V electric accessories which are less than 180 W(Watt) in electric capacity.
- Adjust the air-conditioner or heater to the lowest operating level when using the power outlet.
- Close the cover when not in use.

(Continued)



(Continued)

- **Some electronic devices can cause electronic interference when plugged into a vehicle's power outlet. These devices may cause excessive audio static and malfunctions in other electronic systems or devices used in your vehicle.**
- **Push the plug in as far as it will go. If good contact is not made, the plug may overheat and the fuse may open.**
- **Plug in battery equipped electrical/electronic devices with reverse current protection. The current from the battery may flow into the vehicle's electrical/electronic system and cause system malfunction.**

### USB charger (if equipped)



The USB charger is designed to recharge batteries of small size electrical devices using a USB cable.

The electrical devices can be recharged when the ignition switch or the Engine Start/Stop button is in the ACC, ON or START position.

The battery charging state may be monitored on the electrical device.

Disconnect the USB cable from the USB port after use.

- A smart phone or a tablet PC may get warmer during the re-charging process. It does not indicate any malfunction with the charging system.
- A smart phone or a tablet PC, which adopts a different re-charging method, may not be properly re-charged. In this case, use an exclusive charger of your device.
- The charging terminal is only to recharge a device. Do not use the charging terminal either to turn ON an audio or to play media on the AVN.

## Wireless cellular phone charging system (if equipped)

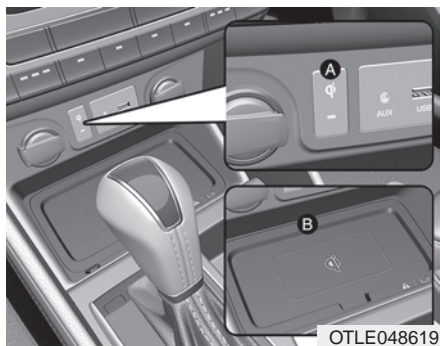

[A] : Indicator, [B] : Charging pad

There is a wireless cellular phone charger inside the front console.

The system is available when all doors are closed, and when the ignition switch is in the ACC/ON position.

### **To charge a cellular phone**

The wireless cellular phone charging system charges only the Qi-enabled cellular phones ( Qi ). Read the label on the cellular phone accessory cover or visit your cellular phone manufacturer's website to check whether your cellular phone supports the Qi technology.

The wireless charging process starts when you put a Qi-enabled cellular phone on the wireless charging unit.

1. Remove other items, including the smart key, from the wireless charging unit. If not, the wireless charging process may be interrupted. Place the cellular phone on the center of charging pad.
2. The indicator light is orange when the cellular phone is charging. The indicator light turns green when phone charging is complete.
3. You can turn ON or OFF the wireless charging function in the User Settings mode on the instrument cluster. For further information, refer to the "LCD Display Modes" in this chapter.

If your cellular phone is not charging:

- Slightly change the position of the cellular phone on the charging pad.
- Make sure the indicator light is orange.

The indicator light will blink orange for 10 seconds if there is a malfunction in the wireless charging system.

In this case, temporarily stop the charging process, and re-attempt to wirelessly charge your cellular phone again.

The system warns you with a message on the LCD display if the cellular phone is still on the wireless charging unit after the engine is turned OFF and the front door is opened.

For certain cellular phone, the message may not be displayed.

(This is due to the characteristic of the certain cellular phone and the wireless cellular phone charging system is normal.)

### NOTICE

- The wireless cellular phone charging system may not support certain cellular phones, which are not verified for the Qi specification ( Qi ).
- Locate your cellular phone in the middle of the wireless cellular phone charging system. Even when your cellular phone locates slightly to one side, the charging speed may decrease and the phone may heat when charging.
- The wireless charging process may temporarily stop, when a smart key function operates (i.e. starting the engine, opening the doors, closing the doors).
- For certain cellular phone, the indicator color may not change to green, even when the wireless charging process is properly completed.

(Continued)

(Continued)

- For certain cellular phones with their own protection, the wireless charging speed may decrease and the wireless charging may stop if the temperature inside the vehicle is too high or low.

When the inside temperature is too high or low do not use the system and wait until the temperature maintains a proper level before using the system.

- The wireless charging process may temporarily stop, when temperature abnormally increases inside the wireless cellular phone charging system. The wireless charging process restarts, when temperature falls to a certain level.

(Continued)

(Continued)

- The wireless charging process may temporarily stop when there is any metallic item, such as a coin, between the wireless cellular phone charging system and a cellular phone.
- For certain cellular phones with their own protection, the wireless charging speed may decrease and the wireless charging may stop.
- If the cellular phone has a thick cover, the wireless charging may not be possible.
- If the cellular phone is not fully in contact with the wireless charging pad, the wireless charging may not be possible.
- Some magnetic items (credit cards, phone cards, passbook and tickets) may be damaged while using the wireless charging process.

## Cigarette lighter (if equipped)



To use the cigarette lighter, the ignition switch must be in the ACC or ON position.

Push the cigarette lighter all the way into its socket. When the element is heated, the lighter will pop out to the “ready” position.

We recommend that you use parts for replacement from an authorized HYUNDAI dealer.

### WARNING

- Do not hold the lighter in after it is already heated because it will overheat.
- If the lighter does not pop out within 30 seconds, remove it to prevent overheating.
- Do not insert foreign objects into the socket of the cigarette lighter. It may damage the cigarette lighter.

### NOTICE

**Only a genuine HYUNDAI lighter should be used in the cigarette lighter socket. The use of plug-in accessories (shavers, hand-held vacuums, and coffee pots, etc.) may damage the socket or cause electrical failure.**

## Clock

### WARNING

**Do not adjust the clock while driving. You may lose your steering control and cause severe personal injury or accidents.**

For more details, please refer to the chapter 4 “Multimedia system” or separate AVN manual that was supplied with your vehicle.

## Clothes hanger (if equipped)

■ Type A

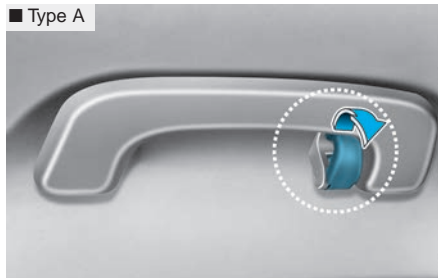

■ Type B

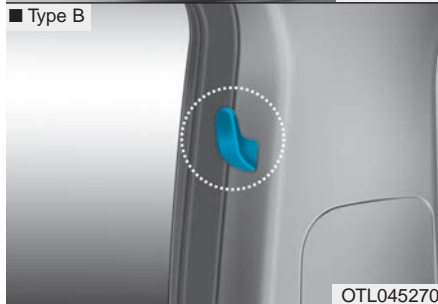

To hang items, pull the hanger down.  
(Type A)

These hangers are not designed to hold large or heavy items.

## ⚠ WARNING

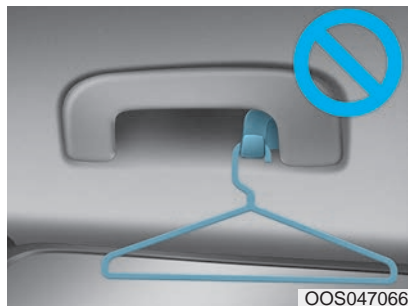

**Do not hang other objects such as hangers or hard objects except clothes. Also, do not put heavy, sharp or breakable objects in the clothes pockets. In an accident or when the curtain air bag is inflated, it may cause vehicle damage or personal injury.**

## Floor mat anchor(s) (if equipped)

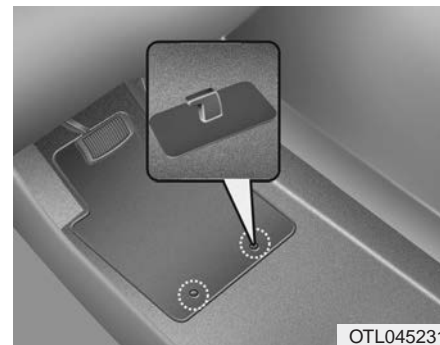

**ALWAYS** use the Floor Mat Anchors to attach the front floor mats to the vehicle. The anchors on the front floor carpet keep the floor mats from sliding forward.

**⚠ WARNING**

The following must be observed when installing ANY floor mat to the vehicle.

- Ensure that the floor mats are securely attached to the vehicle's floor mat anchor(s) before driving the vehicle.
- Do not use ANY floor mat that cannot be firmly attached to the vehicle's floor mat anchors.
- Do not stack floor mats on top of one another (e.g. all-weather rubber mat on top of a carpeted floor mat). Only a single floor mat should be installed in each position.

**IMPORTANT** - Your vehicle was manufactured with driver's side floor mat anchors that are designed to securely hold the floor mat in place. To avoid any interference with pedal operation, HYUNDAI recommends that the HYUNDAI floor mat designed for use in your vehicle be installed.

**Luggage net (holder)**

To keep items from shifting in the cargo area, you can use the four holders located in the cargo area to attach the luggage net.

If necessary, we recommend that you contact your authorized HYUNDAI dealer to obtain a luggage net.

**NOTICE**

Vehicles equipped with a luggage rail system may use the shackles to hook the luggage net.

**⚠ CAUTION**

To prevent damage to the goods or the vehicle, care should be taken when carrying fragile or bulky objects in the luggage compartment.

**⚠ WARNING**

To avoid eye injury, **DO NOT** overstretch the luggage net. **ALWAYS** keep your face and body out of the luggage net's recoil path. **DO NOT** use the luggage net when the strap has visible signs of wear or damage.

## Cargo security screen (if equipped)



Use the cargo security screen to hide items stored in the cargo area.

### NOTICE

Since the cargo security screen may be damaged or malformed, do not put luggage on it when it is used.

### ⚠ WARNING

- Do not place objects on the cargo security screen. Such objects may be thrown about inside the vehicle and possibly injure vehicle occupants during an accident or when braking.
- Never allow anyone to ride in the luggage compartment. It is designed for luggage only.
- Maintain the balance of the vehicle and locate the weight as forward as possible.

## To use the cargo security screen

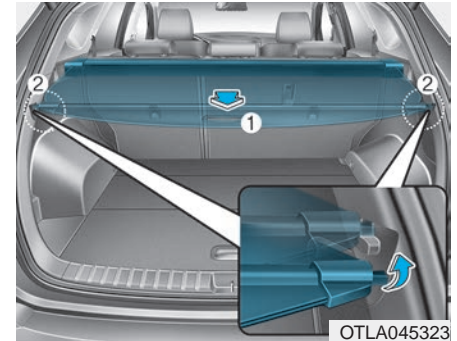

1. Pull the cargo security screen towards the rear of the vehicle by the handle (1).
2. Insert the guide pin into the guide (2).

### NOTICE

Pull out the cargo security screen with the handle in the center to prevent the guide pin from falling out of the guide.



When the cargo security screen is not in use:

1. Pull the cargo security screen backward and up to release it from the guides.
2. The cargo security screen will automatically slide back in.

**NOTICE**

The cargo security screen may not automatically slide back in if the cargo security screen is not fully pulled out. Fully pull it out and then let go.

**To remove the cargo security screen**

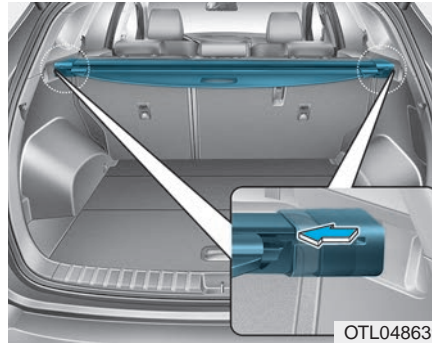

1. Push in the guide pin.
2. While pushing the guide pin, pull out the cargo security screen.

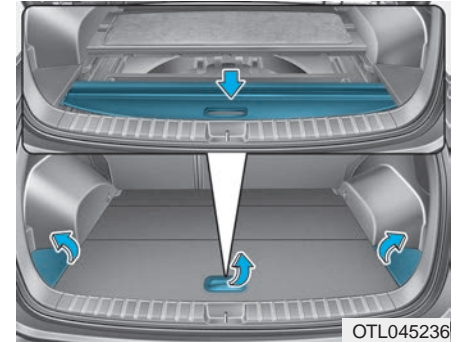

3. Open the luggage tray and keep the cargo security screen in the tray.



**To remove the cargo security screen from the luggage tray**

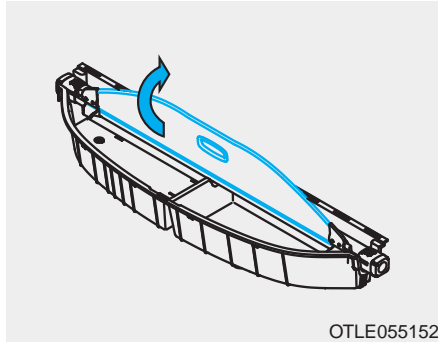

1. Pull up the screen board.

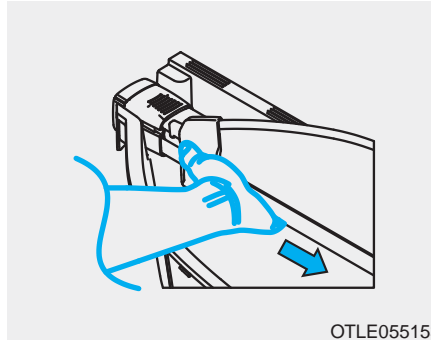

2. Push in the guide pin.

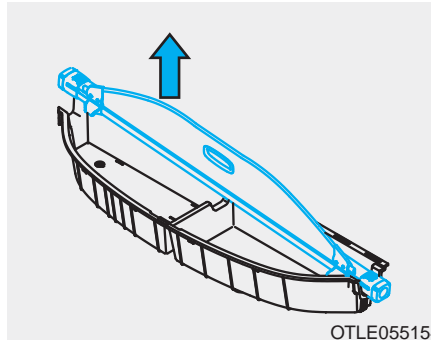

3. While pushing the guide pin, pull out the cargo security screen.

**Luggage tray (if equipped)**

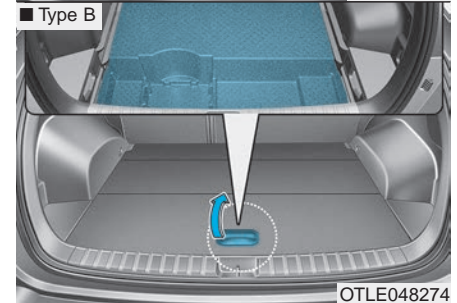
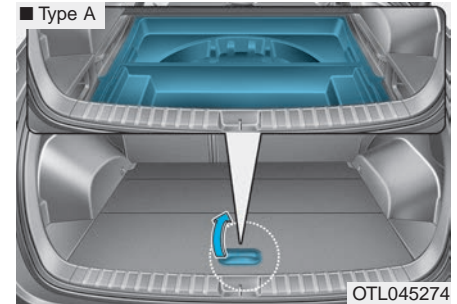

You can place a first aid kit, a reflector triangle, tools, etc. in the box for easy access.

- Grasp the handle on the top of the cover and lift it.

## EXTERIOR FEATURES

### Roof rack (if equipped)

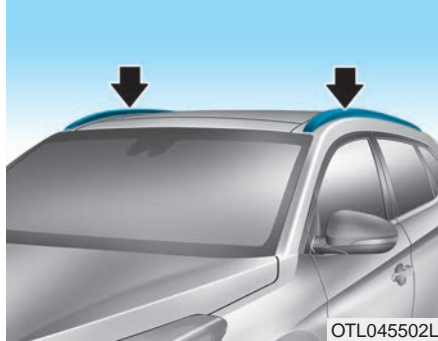

If the vehicle has a roof rack, you can load cargo on top of your vehicle.

#### NOTICE

If the vehicle is equipped with a sunroof, be sure not to position cargo onto the roof rack in such a way that it could interfere with sunroof operation.

#### NOTICE

- When carrying cargo on the roof rack, take the necessary precautions to make sure the cargo does not damage the roof of the vehicle.
- When carrying large objects on the roof rack, make sure they do not exceed the overall roof length or width.

#### ⚠ WARNING

- The following specification is the maximum weight that can be loaded onto the roof rack. Distribute the load as evenly as possible onto the roof rack and secure the load firmly.

ROOF RACK	100 kg (220 lbs.) EVENLY DISTRIBUTED
-----------	---

Loading cargo or luggage in excess of the specified weight limit on the roof rack may damage your vehicle.

(Continued)

(Continued)

- The vehicle center of gravity will be higher when items are loaded onto the roof rack. Avoid sudden starts, braking, sharp turns, abrupt maneuvers or high speeds that may result in loss of vehicle control or rollover resulting in an accident.
- Always drive slowly and turn corners carefully when carrying items on the roof rack. Severe wind updrafts, caused by passing vehicles or natural causes, can cause sudden upward pressure on items loaded on the roof rack. This is especially true when carrying large, flat items such as wood panels or mattresses. This could cause the items to fall off the roof rack and cause damage to your vehicle or others around you.
- To prevent damage or loss of cargo while driving, check frequently before or while driving to make sure the items on the roof rack are securely fastened.

# Multimedia System

<b>Multimedia system</b> .....	4-2
AUX, USB and iPod® port .....	4-2
Antenna .....	4-3
Steering wheel audio control .....	4-4
Audio / Video / Navigation system (AVN) .....	4-5
Bluetooth® Wireless Technology hands-free .....	4-5
How vehicle audio works .....	4-6
<b>Audio (Without Touch Screen)</b> .....	4-14
System layout - control panel .....	4-14
System layout - steering wheel remote control .....	4-16
Turning the system on or off .....	4-19
Turning the display on or off .....	4-19
Getting to know the basic operations .....	4-20
<b>Radio</b> .....	4-21
Turning on the radio .....	4-21
Changing the radio mode .....	4-22
Scanning for available radio stations .....	4-22
Searching for radio stations .....	4-23
Saving radio stations .....	4-23
Listening to saved radio stations .....	4-23
<b>Media Player</b> .....	4-24
Using the media player .....	4-24
Using the USB mode .....	4-25
Using the iPod mode .....	4-27
Using the AUX mode .....	4-30
<b>Bluetooth</b> .....	4-31
Connecting Bluetooth devices .....	4-31
Using a Bluetooth audio device .....	4-34
Using a Bluetooth phone .....	4-36
<b>Setup</b> .....	4-42
Display .....	4-42
Sound .....	4-42
Date/Time .....	4-43
Bluetooth .....	4-43
System .....	4-43
<b>System Status Icons</b> .....	4-44
<b>Audio System Specifications</b> .....	4-45
USB .....	4-45
Bluetooth .....	4-46
<b>Trademarks</b> .....	4-47
<b>Declaration of Conformity</b> .....	4-48
CE RED for EU .....	4-48
FCC .....	4-49
IFETEL for Mexico .....	4-50

## MULTIMEDIA SYSTEM

### **i** Information

- If you install an aftermarket HID headlamp, your vehicle's audio and electronic device may malfunction.
- Prevent chemicals such as perfume, cosmetic oil, sun cream, hand cleaner, and air freshener from contacting the interior parts because they may cause damage or discoloration.

### AUX, USB and iPod® port



You can use an AUX port to connect audio devices and an USB port to plug in an USB and also in an iPod® port.

### **i** Information

When using a portable audio device connected to the power outlet, noise may occur during playback. If this happens, use the power source of the portable audio device.

\* iPod® is a trademark of Apple Inc.

## Antenna

### Roof antenna



The roof antenna receives both AM and FM broadcast signals. Rotate the roof antenna in a counterclockwise direction to remove it. Rotate it in a clockwise direction to reinstall it.

### Shark fin antenna

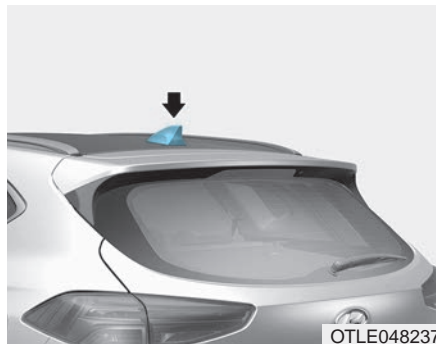

The shark fin antenna receives transmitted data. (for example: GPS and DAB signals)

### NOTICE

- To prevent damage to the rear glass antenna, never use sharp instruments or window cleaner containing abrasives to clean the window. Clean the inside surface of the rear glass window with a piece of soft cloth.
- When putting a sticker on the inside surface of the rear window, be careful not to damage to the rear glass antenna.
- Do not put sharp instruments nearby the rear glass antenna.
- Tinted rear window may affect the proper functioning of the antenna.

## Steering wheel audio control (if equipped)

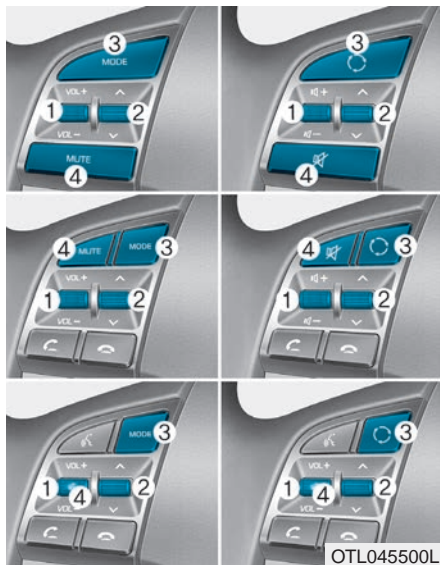

The steering wheel audio control button is installed for your convenience.

### NOTICE

**Do not operate audio remote control buttons simultaneously.**

### **VOLUME (VOL +/-) (1)**

- Move the VOLUME lever up to increase volume.
- Move the VOLUME lever down to decrease volume.

### **SEEK/PRESET (^ / v) (2)**

If the SEEK/PRESET lever is moved up or down and held for 0.8 second or more, it will function in the following modes.

#### **RADIO mode**

It will function as the AUTO SEEK select button. It will SEEK until you release the button.

#### **MEDIA mode**

It will function as the FF/REW button.

If the SEEK/PRESET lever is moved up or down, it will function in the following modes.

#### **RADIO mode**

It will function as the PRESET STATION UP/DOWN button.

#### **MEDIA mode**

It will function as the TRACK UP/DOWN button.

### **MODE (⊙) (3)**

Press the MODE button to select Radio, Disc, or AUX.

### **MUTE (⊘) (4, if equipped)**

- Press the button to mute the sound.
- Press the button again to activate the sound.

### **i Information**

**Detailed information for audio control buttons are described in the following pages in this chapter.**

## Audio / Video / Navigation system (AVN) (if equipped)

Detailed information for the AVN system is described in a separately supplied manual.

## Bluetooth® Wireless Technology hands-free (if equipped)

You can use the phone wirelessly by using the *Bluetooth®* Wireless Technology.

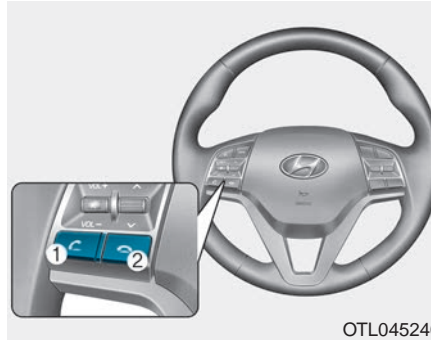

- (1) Call / Answer button
- (2) Call end button



- (3) Microphone

- Audio : For detailed information, refer to “AUDIO” in this chapter.
- AVN : Detailed information for the *Bluetooth®* Wireless Technology hands-free is described in the manual supplied separately.

### **i** Information

Make sure that your mobile phone system is up to date to assure proper function of bluetooth connection.

## How Vehicle Audio Works

### FM reception

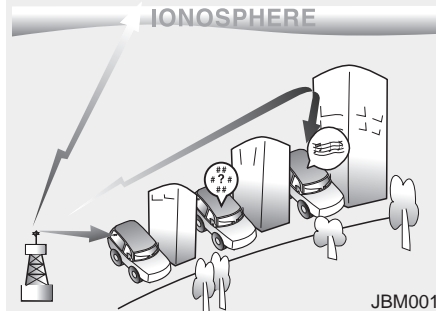

AM and FM radio signals are broadcast from transmitter towers located around your city. They are intercepted by the radio antenna on your vehicle. This signal is then processed by the radio and sent to your vehicle speakers.

When a strong radio signal has reached your vehicle, the precise engineering of your audio system ensures the best possible quality reproduction. However, in some cases the signal coming to your vehicle may not be strong and clear.

This can be due to factors, such as the distance from the radio station, closeness of other strong radio stations or the presence of buildings, bridges or other large obstructions in the area.

### AM reception

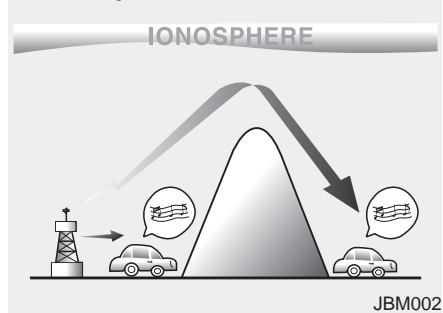

AM broadcasts can be received at greater distances than FM broadcasts. This is because AM radio waves are transmitted at low frequencies. These long distance, low frequency radio waves can follow the curvature of the earth rather than travelling straight. In addition, they curve around obstructions resulting in better signal coverage.

### FM radio station

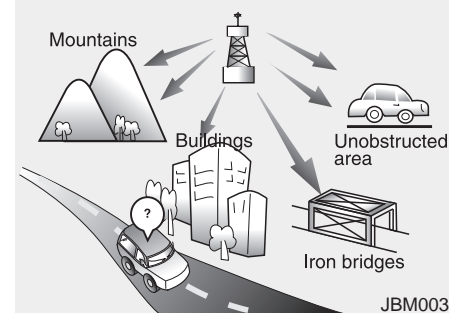

FM broadcasts are transmitted at high frequencies and do not bend to follow the earth's surface. Because of this, FM broadcasts generally begin to fade within short distances from the station. Also, FM signals are easily affected by buildings, mountains, and obstructions. This can lead to undesirable or unpleasant listening conditions which might lead you to believe a problem exists with your radio. The following conditions are normal and do not indicate radio trouble:



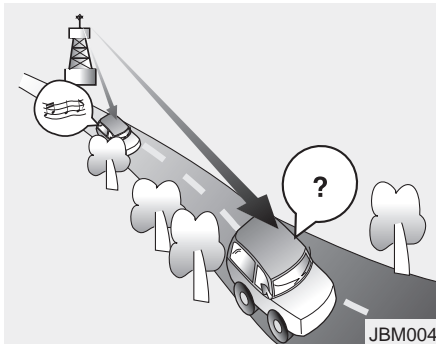

- **Fading** - As your vehicle moves away from the radio station, the signal will weaken and sound will begin to fade. When this occurs, we suggest that you select another stronger station.
- **Flutter/Static** - Weak FM signals or large obstructions between the transmitter and your radio can disturb the signal causing static or fluttering noises to occur. Reducing the treble level may lessen this effect until the disturbance clears.

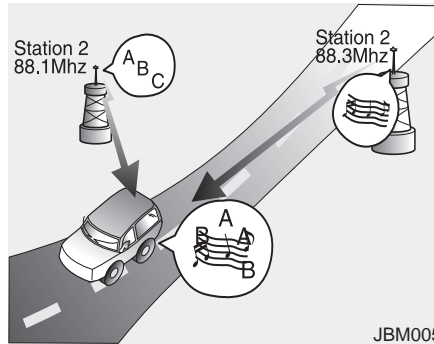

- **Station Swapping** - As an FM signal weakens, another more powerful signal near the same frequency may begin to play. This is because your radio is designed to lock onto the clearest signal. If this occurs, select another station with a stronger signal.
- **Multi-Path Cancellation** - Radio signals being received from several directions can cause distortion or fluttering. This can be caused by a direct and reflected signal from the same station, or by signals from two stations with close frequencies. If this occurs, select another station until the condition has passed.

### ***Using a cellular phone or a two-way radio***

When a cellular phone is used inside the vehicle, noise may be produced from the audio system. This does not mean that something is wrong with the audio equipment. In such a case, try to operate mobile devices as far from the audio equipment as possible.

#### **⚠ CAUTION**

**When using a communication system such as a cellular phone or a radio set inside the vehicle, a separate external antenna must be fitted. When a cellular phone or a radio set is used with an internal antenna alone, it may interfere with the vehicle's electrical system and adversely affect safe operation of the vehicle.**

#### **⚠ WARNING**

**Do not use a cellular phone while driving. Stop at a safe location to use a cellular phone.**

**NOTE:**

**Order of playing files (folders) :**

1. Song playing order : ① to ⑭ sequentially.

2. Folder playing order :

\* If no song file is contained in the folder, that folder is not displayed.

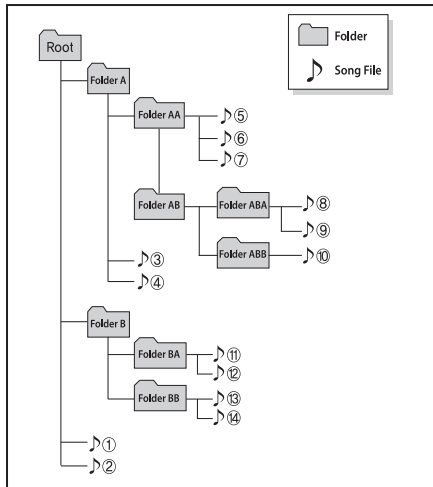
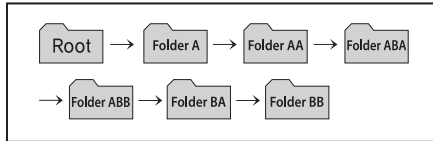

**! WARNING**

- Do not stare at the screen while driving. Staring at the screen for prolonged periods of time could lead to traffic accidents.
- Do not disassemble, assemble, or modify the audio system. Such acts could result in accidents, fire, or electric shock.
- Using the phone while driving may lead to a lack of attention of traffic conditions and increase the likelihood of accidents. Use the phone feature after parking the vehicle.
- Heed caution not to spill water or introduce foreign objects into the device. Such acts could lead to smoke, fire, or product malfunction.

**! CAUTION**

- Operating the device while driving could lead to accidents due to a lack of attention to external surroundings. First park the vehicle before operating the device.
- Adjust the volume to levels that allow the driver to hear sounds from outside of the vehicle. Driving in a state where external sounds cannot be heard may lead to accidents.
- Pay attention to the volume setting when turning the device on. A sudden output of extreme volume upon turning the device on could lead to hearing impairment. (Adjust the volume to a suitable level before turning off the device.)

**NOTICE**

- Do not place beverages close to the audio system. Spilling beverages may lead to system malfunction.
- In case of product malfunction, please contact your place of purchase or After Service center.
- Placing the audio system within an electromagnetic environment may result in noise interference.
- Prevent caustic solutions such as perfume and cosmetic oil from contacting the dashboard because they may cause damage or discoloration.

**i Information - Using the USB device**

- Connect the USB device after turning on the engine. The USB device may become damaged if it is already connected when the ignition is turned on. The USB device may not operate properly if the car ignition is turned on or off with the USB device connected.
- Heed caution to static electricity when connecting/disconnecting USB devices.
- Encoded MP3 Players will not be recognized when connected as an external device.
- When connecting an external USB device, the device may not properly recognize the USB is in some states.
- Only products formatted with byte/sectors under 64Kbyte will be recognized.
- This device recognizes USB devices formatted in FAT 12/16/32 file formats. This device does not recognize files in NTFS file format.
- Some USB devices may not be supported due to compatibility issues.

(Continued)

(Continued)

- Avoid contact between the USB connector with bodily parts or foreign objects.
- Repeated connecting/disconnecting of USB devices within short periods of time may result in product malfunction.
- A strange noise may occur when disconnecting the USB.
- Make sure to connect/disconnect external USB devices with the audio power turned off.
- The amount of time required to recognize the USB device may differ depending on the type, size or file formats stored in the USB. Such differences in time are not indications of malfunctions.
- The device only supports USB devices used to play music files.
- USB images and videos are not supported.
- Do not use the USB I/F to charge batteries or USB accessories that generate heat. Such acts may lead to worsened performance or damage to the device.

(Continued)

(Continued)

- The device may not recognize the USB device if separately purchased USB hubs and extension cables are being used. Connect the USB directly with the multimedia terminal of the vehicle.
- When using mass storage USB devices with separate logical drives, only files saved to the root drive can be played.
- Files may not properly operate if application programs are installed to the USBs.
- The device may not operate normally if MP3 Players, cellular phones, digital cameras, or other electronic devices (USB devices not recognized as portable disk drives) are connected with the device.
- Charging through the USB may not work for some mobile devices.
- The device may not support normal operation when using a USB memory type besides (Metal Cover Type) USB Memory.

(Continued)

(Continued)

- The device may not support normal operation when using formats such as HDD Type, CF, or SD Memory.
- The device will not support files locked by DRM (Digital Rights Management.)
- USB memory sticks used by connecting an Adaptor (SD Type or CF Type) may not be properly recognized.
- The device may not operate properly when using USB HDDs or USBs subject to connection failures caused by vehicle vibrations. (e.g. i-stick type)
- Avoid use of USB memory products that can also be used as key chains or mobile phone accessories. Use of such products may cause damage to the USB jack.
- Connecting an MP3 device or phone through various channels, such as AUX/BT or Audio/ USB mode may result in pop noises or abnormal operation.



### **i** Information - Using the iPod® device

- iPod® is a registered trademark of Apple Inc.
- In order to use the iPod® while operating the keys, you must use a dedicated iPod® cable. (the cable that is supplied when purchasing iPod® /iPhone® products)
- If the iPod® is connected to the vehicle while it is playing, a high pitch sound could occur for approximately 1-2 seconds immediately after connecting. If possible, connect the iPod to the vehicle with the iPod® stopped/ paused.
- During ACC ON state, connecting the iPod® through the iPod® cable will charge the iPod® through the car audio system.
- When connecting with the iPod® cable, make sure to fully insert the jack to prevent communication interference.

(Continued)

(Continued)

- When the EQ features of an external device, such as the iPod®, and the audio system are both active, EQ effects could overlap and cause sound deterioration and distortion. Whenever possible, turn off the EQ feature within the external device upon use by connecting with the audio system.
- Noise may occur when an iPod® or AUX device is connected. When such devices are not being used, disconnect the device for storage.
- When the iPod® or AUX device power is connected to the power jack, playing the external device may result in noise. In such cases, disconnect the power connection before use.
- Skipping or improper operation may occur depending on the characteristics of your iPod® /Phone® device.

(Continued)

(Continued)

- If your iPhone® is connected to both the *Bluetooth*® Wireless Technology and USB, the sound may not be properly played. In your iPhone®, select the Dock connector or *Bluetooth*® Wireless Technology to change the sound output (source).
- iPod mode cannot be operated when the iPod® cannot be recognized due to versions that do not support communication protocols.
- For fifth generation iPod® Nano devices, the iPod® may not be recognized when the battery level is low. Please charge the iPod® for use.
- Search/play orders shown within the iPod® device may differ with the orders shown within the audio system.
- If the iPod® malfunctions due to an iPod® device defect, reset the iPod® and try again. (To learn more, refer to your iPod® manual)
- Some iPod®s may not sync with the System depending on its version. If the Media is removed before the Media is recognized, then the system may not properly restore the previously operated mode. (iPod® charging is not supported.)

### **i** Information - Using the AUX device

- If an external device connector is connected with the AUX terminal, then AUX mode will automatically operate. Once the connector is disconnected, the previous mode will be restored.
- AUX mode can be used only when an external audio player (camcorder, car VCR, etc.) has been connected.
- The AUX volume can be controlled separately from other audio modes.
- Connecting a connector jack to the AUX terminal without an external device will convert the system to AUX mode, but only output noise. When an external device is not being used, also remove the connector jack.
- When the external device power is connected to the power jack, playing the external device may output noise. In such cases, disconnect the power connection before use.
- Fully insert the AUX cable to the AUX jack upon use.

**i** Information - Before using the Bluetooth® handsfree

**What is Bluetooth® ?**

- Bluetooth® refers to a short-distance wireless networking technology which uses a 2.4GHz ~ 2.48GHz frequency to connect various devices within a certain distance.
- Supported within PCs, external devices, Bluetooth® phones, PDAs, various electronic devices, and automotive environments, Bluetooth® allows data to be transmitted at high speeds without having to use a connector cable.
- Bluetooth® Handsfree refers to a device which allows the user to conveniently make phone calls with Bluetooth® mobile phones through the audio system.
- Bluetooth® Handsfree may not be supported in some mobile phones. To learn more about mobile device compatibility, visit [www.hyundaiusa.com](http://www.hyundaiusa.com).

**i** Information - Precautions for safe driving

- Bluetooth® Handsfree is a feature that enables drivers to practice safe driving. Connecting the head unit with a Bluetooth® phone allows the user to conveniently make and receive calls and use contacts. Before using Bluetooth®, carefully read the contents of this user's manual.
- Excessive use or operations while driving may lead to negligent driving practices and result in accidents. Refrain from excessive operations while driving.
- Viewing the screen for prolonged periods of time is dangerous and may lead to accidents. When driving, view the screen only for short periods of time.

**i** Information - When connecting a Bluetooth® phone

- Before connecting the head unit with the mobile phone, check to see that the mobile phone supports Bluetooth® features.
- Even if the phone supports Bluetooth®, the phone will not be found during device searches if the phone has been set to hidden state or the Bluetooth® power is turned off. Disable the hidden state or turn on the Bluetooth® power prior to searching/connecting with the Head unit.
- Bluetooth phone is automatically connected when the ignition on.
- If you do not want automatic connection with your Bluetooth® device, turn off the Bluetooth® feature within your mobile phone.
- The Handsfree call volume and quality may differ depending on the mobile phone.

(Continued)

(Continued)

- Park the vehicle when connecting the head unit with the mobile phone.
- Bluetooth® connection may become intermittently disconnected in some mobile phones. Follow these steps to try again.
  1. Within the mobile phone, turn the Bluetooth® function off/on and try again.
  2. Turn the mobile phone power Off/On and try again.
  3. Completely remove the mobile phone battery, reboot, and then again.
  4. Reboot the Audio System and try again.
  5. Delete all paired devices, pair and try again.
- Handsfree call quality and volume may differ depending on the model of your mobile phone.

### **i** Information - Using the voice recognition

- When using the voice recognition feature, only commands listed within the user's manual are supported.
- Be aware that during the operation of the voice recognition system, pressing any key other than the  key terminate voice recognition mode.
- For superior voice recognition performance, position the microphone used for voice recognition above the head of the driver's seat and maintain a proper position when saying commands.
- Within the following situations, voice recognition may not function properly due to external sound.
  - When the windows and sunroof are open
  - When the wind of the cooling / heating device is strong
  - When entering and passing through tunnels

(Continued)

(Continued)

- When driving on rugged and uneven roads
- During severe rain (heavy rains, windstorms)
- Phone related voice commands can be used only when a *Bluetooth*® Wireless Technology device is connected.
- When making calls by stating a name, the corresponding contact must be downloaded and stored within the audio system.
- After downloading the *Bluetooth*® Wireless Technology phone book, it takes some times to convert the phone book data into voice information. During this time, voice recognition may not properly operate.
- Pronounce the voice commands naturally and clearly as if in a normal conversation.

## AUDIO (Without Touch Screen) System layout – control panel

■ Type A



■ Type B



(With *Bluetooth*® Wireless Technology)

(1) **SEEK/TRACK button**

- Change the station/track/file (except for the AUX mode).
- While listening to the radio, press and hold to search for a station.
- While playing media, press and hold to rewind or fast forward (except for the AUX and Bluetooth audio modes).

(2) **RADIO button**

- Press to turn on the radio. While listening to the radio, press to change the radio mode.

(3) **MEDIA button**

- Press to play content from a media storage device. Press repeatedly to switch modes between USB (iPod), Bluetooth audio, and AUX.
- If you have multiple media storage devices, select one from the media selection window.

(4) **PHONE button**

- Press to start connecting a mobile phone via Bluetooth.
- After a Bluetooth phone connection is made, press to access the Bluetooth phone menu.

(5) **POWER button/VOL knob**

- Press to turn the system on or off.
- Turn to the left or right to adjust the system sound volume.

(6) **Reset button**

\* The actual features in the vehicle may differ from the illustration.



## ■ Type A



## ■ Type B



(With *Bluetooth*® Wireless Technology)

**(7) PRESET button**

- While listening to the radio, press to move to previous or next page of the preset list.

**(8) SETUP button/CLOCK button**

- Press to access the setup screen.
- Press and hold to access the time setup screen.

**(9) BACK button**

- Press to return to the previous screen.

**(10) MENU button**

- Press to access the menu screen for the current mode.

**(11) TUNE knob/FILE knob/ENTER button**

- While listening to the radio, turn to adjust the frequency.
- While playing media, turn to search for a track/file (except for the AUX and Bluetooth audio modes).
- During a search, press to select the current track/file.

**(12) Number buttons (1–6)**

- While listening to the radio, press to listen to a saved radio station.
- While listening to the radio, press and hold to save the current radio station to the preset.
- Press the corresponding number button to select an item.

\* The actual features in the vehicle may differ from the illustration.

## System layout – steering wheel remote control

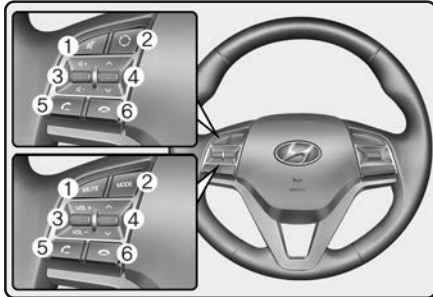

(Bluetooth® equipped model)

※ The actual features in the vehicle may differ from the illustration.

### (1) MUTE button

- Press to mute or unmute the system.
- During a call, press to mute or unmute the microphone.

### (2) MODE button

- Press to switch between radio and media modes.
- Press and hold to turn the system on or off. (if equipped)

### (3) Volume lever

- Push up or down to adjust the volume.

### (4) Up/Down lever

- Change the station/track/file (except for the AUX mode).
- While listening to the radio, push to listen to the previous/next saved radio station.
- While listening to the radio, push and hold to search for a station.
- While playing media, push and hold to rewind or fast forward (except for the AUX and Bluetooth audio modes).

### (5) Call/Answer button

- Press to start connecting a mobile phone via Bluetooth.
- After a Bluetooth phone connection is made, access the Bluetooth phone screen. Press and hold to dial the most recent phone number. When a call comes in, press to answer the call.
- During a call, press to switch between the active call and the held call. Press and hold to switch the call between the system and the mobile phone.

### (6) Call end button

**⚠ WARNING**  
- About driving

- Do not operate the system while driving. Driving while distracted may result in a loss of vehicle control, potentially leading to an accident, severe personal injury, or death. The driver's primary responsibility is the safe and legal operation of a vehicle, and any handheld devices, equipment, or vehicle systems which divert the driver's attention from this responsibility should never be used during operation of the vehicle.

(Continued)

(Continued)

- Avoid watching the screen while driving. Driving while distracted may lead to a traffic accident. Stop your vehicle in a safe location before using functions that require multiple operations.
- Stop your vehicle first before using your mobile phone. Using a mobile phone while driving may lead to a traffic accident. If necessary, use the Bluetooth Handsfree feature to make calls and keep the call as short as possible.
- Keep the volume low enough to hear external sounds. Driving without the ability to hear external sounds may lead to a traffic accident. Listening to a loud volume for a long time may cause hearing damage.

**⚠ WARNING**  
- About handling the system

- Do not disassemble or modify the system. Doing so may result in an accident, fire, or electric shock.
- Do not allow liquids or foreign substances to enter the system. Liquids or foreign substances may cause noxious fumes, a fire, or a system malfunction.
- Stop using the system if it malfunctions, such as no audio output or display. If you continue using the system when it is malfunctioning, it may lead to a fire, electric shock, or system failure.
- Do not touch the antenna during thunder or lightning because such an act may cause electric shock.

### **i** Information

#### - About operating the system

- Use the system with the engine running. Using the system for a long time when the engine is stopped may discharge the battery.
- Do not install unapproved products. Using unapproved products may cause an error while using the system. System errors caused by installing unapproved products are not covered under the warranty.

### **i** Information

#### - About handling the system

- Do not apply excessive force to the system. Excessive pressure on the screen may damage the LCD panel or the touch panel.
- When cleaning the screen or button panel, make sure to stop the engine and use a soft, dry cloth. Wiping the screen or buttons with a rough cloth or using solvents (alcohol, benzene, paint thinner, etc.) may scratch or chemically damage the surface.
- If you attach a liquid-type air freshener to the fan louvre, the surface of the louvre may become deformed due to the flowing air.
- If you want to change the position of the installed device, please inquire with your place of purchase or service maintenance centre. Technical expertise is required to install or disassemble the device.

### **NOTICE**

- If you experience any problems with the system, contact your place of purchase or dealer.
- Placing the audio system within an electromagnetic environment may result in noise interference.

## Turning the system on or off

To turn on the system, start the engine.

- If you do not want to use the system while driving, you can turn off the system by pressing the [POWER] button on the control panel. To use the system again, press the [POWER] button again.

The system turns off when you stop the engine (ACC Off).

- When you turn back on the system, the previous mode and settings will remain intact.

### WARNING

- **Some functions may be disabled for safety reasons while the vehicle is moving. They work only when the vehicle stops. Park your vehicle in a safe location before using any of them.**
- **Stop using the system if it malfunctions, such as no audio output or display. If you continue using the system when it is malfunctioning, it may lead to a fire, electric shock, or system failure.**

### Information

You can turn on the system when the key ignition switch is placed in the “ACC” or “ON” position. Using the system for an extended period without the engine running drains the battery. If you plan on using the system for a long time, start the engine.

## Turning the display on or off

To prevent glare, you can turn off the screen. The screen can be turned off only while the system is on.

1. On the control panel, press the [SETUP/CLOCK] button.
2. On the control panel, press the [6] button to select **Display Off**.
  - To turn the screen back on, press any of the control panel buttons.

### Getting to know the basic operations

You can select an item or adjust the settings by using the number buttons and the [TUNE] knob on the control panel.

#### Selecting an item

##### Numbered items

Press the corresponding number button.

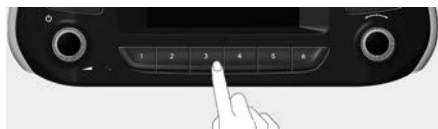
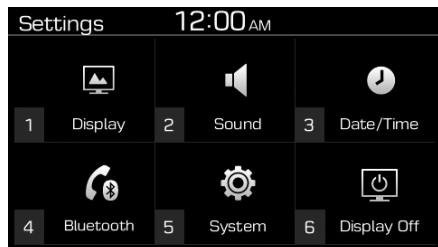

##### Numberless items

Turn the [TUNE] knob to select the desired item, and then press the knob.

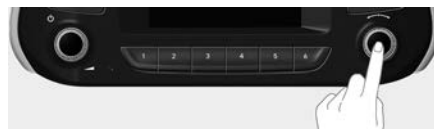
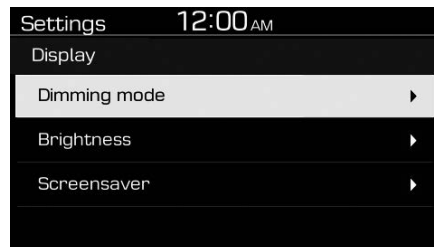

#### Adjusting the settings

Turn the [TUNE] knob to adjust the value, and then press the knob to save changes.

Turn the [TUNE] knob to the right to increase the value and turn the [TUNE] knob to the left to decrease the value.

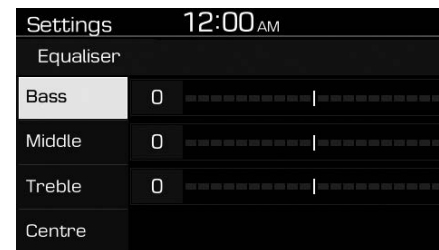

## RADIO

### Turning on the radio

On the control panel, press the [RADIO] button.

### FM/AM Mode



- (1) Current radio mode
- (2) Radio station information
- (3) Preset list

Press the [MENU] button on the control panel to access the following menu options:

- **List:** Display all available radio stations.
- **Scan:** The system searches for radio stations with strong radio signals and plays each radio station for about five seconds.

- **Sound Settings:** Customise the system sound settings.

### FM/AM Mode (With RDS)

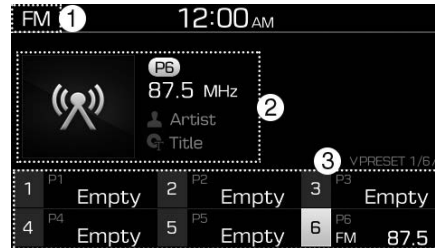

- (1) Current radio mode
- (2) Radio station information
- (3) Preset list

Press the [MENU] button on the control panel to access the following menu options:

- **List:** Display all available radio stations.
- **Traffic Announcement (TA)** (if equipped): Activate or deactivate traffic announcements. Announcements and programmes will be received automatically if available.

- **Scan:** The system searches for radio stations with strong radio signals and plays each radio station for about five seconds.
- **Sound Settings:** Customise the system sound settings.

### DAB/FM Mode (With DAB)



- (1) Current radio mode
- (2) Radio station information
- (3) Preset list

Press the **[MENU]** button on the control panel to access the following menu options:

- **List:** Display all available radio stations.
- **Traffic Announcement (TA):** Activate or deactivate traffic announcements. Announcements and programmes will be received automatically if available.
- **Region:** Enable or disable automatic switching between regional stations.

- **Sound Settings:** Customise the system sound settings.
- **Scan:** The system searches for radio stations with strong radio signals and plays each radio station for about five seconds.
- **Manual tune FM:** Tune the radio frequency manually.

### Changing the radio mode

Alternatively, press the **[RADIO]** button on the control panel or the **[MODE]** button on the steering wheel. Each time you press the button, the radio mode switches.

### Scanning for available radio stations

You can listen to each radio station for a few seconds to test the reception and select the one you want.

1. From the radio screen, press the **[MENU]** button on the control panel.
2. Turn the **[TUNE]** knob to select **Scan**, and then press the knob.
  - The system searches for radio stations with strong radio signals and plays each radio station for about five seconds.
3. When you find the radio station you want to listen to, press the **[TUNE]** knob.
  - You can continue listening to the selected station.



## Searching for radio stations

To search for the previous or next available radio station, press the [✓ **SEEK/TRACK** ^] button on the control panel.

- You can also press and hold the [✓ **SEEK/TRACK** ^] button to search for frequencies quickly. When you release the button, a radio station with a strong signal is selected automatically. (if equipped)

If you know the exact frequency of the radio station you want to listen to, turn the [TUNE] knob on the control panel to change the frequency.

## Saving radio stations

You can save your favourite radio stations and listen to them by selecting them from the preset list.

While listening to the radio, press the number button for an empty preset slot on the radio screen.

- The radio station you are listening to will be added to the selected number.

### NOTICE

- **You can save up to 36 radio stations.**
- **If the preset list is full, you can replace one of your favourite stations with the station you are listening to. On the control panel, press and hold the desired number button.**

## Listening to saved radio stations

1. Confirm the preset number for the radio station you want to listen to.
2. On the control panel, press the desired number button.
  - Alternatively, push the Up/Down lever on the steering wheel to change the station.

## MEDIA PLAYER

### Using the media player

You can play music stored in various media storage devices, such as USB storage devices, smartphones, and iPods.

1. Connect a device to the USB port or the AUX port in your vehicle.
  - Playback may start immediately depending on the device that you connect to the system.
2. On the control panel, press the [MEDIA] button.
  - If you have multiple media storage devices, press the [MEDIA] button again and press the corresponding number button to select the desired mode.

#### NOTICE

- **When you connect an Apple device, playback does not start automatically. To start the media player in the iPod mode, press the [MEDIA] button on the control panel.**
- **You can also change the mode by press the [MODE] button repeatedly on the steering wheel.**
- **Make sure to connect or disconnect external USB devices with the system power turned off.**
- **Depending on vehicle models and specifications, available buttons or the appearance and layout of the USB/AUX ports in your vehicle may vary.**
- **Do not connect a smartphone or an MP3 device to the system via multiple methods such as USB, Bluetooth, and AUX, simultaneously. Doing so may cause a distorted noise or a system malfunction.**

(Continued)

(Continued)

- **When the equaliser function of the connected device and Equaliser (Tone) settings of the system are both activated, the effects may interfere with each other and may lead to sound degradation or distortion. Deactivate the device's equaliser function if possible.**
- **Noise may occur when an Apple device or AUX device is connected. When such devices are not being used, disconnect the device for storage.**
- **When the Apple device or AUX device power is connected to the power jack, playing the external device may result in noise. In such cases, disconnect the power connection before use.**

## Using the USB mode

You can play media files stored in portable devices, such as USB storage devices and MP3 players. Check compatible USB storage devices and file specifications before using the USB mode.

Connect your USB device to the USB port in the vehicle.

- Playback starts immediately.
- If a USB device is already connected to the system, press the **[MEDIA]** button and press the **[1]** button to select **USB** from the media selection window.

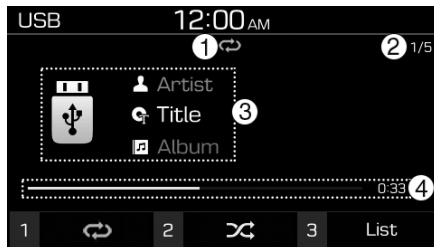

- (1) Repeat play mode
- (2) Current file number and total number of files
- (3) Information about the song currently playing
- (4) Playback time and playback position

Press the **[MENU]** button on the control panel to access the following menu options:

- **Information:** Display information about the song currently playing.
- **Sound Settings:** Customise the system sound settings.

## Rewinding/Fast forwarding

On the control panel, press and hold the **[√ SEEK/TRACK ^]** button.

- You can also push and hold the Up/Down lever on the steering wheel.

## Restarting the current playback

On the control panel, press the **[√ SEEK/TRACK]** button.

- You can also push the Down lever on the steering wheel.

## Playing the previous or next song

To play the previous song, press the **[√ SEEK/TRACK]** button twice on the control panel. To play the next song, press the **[SEEK/TRACK ^]** button on the control panel.

- You can also use the Up/Down lever on the steering wheel.

### NOTICE

- On the control panel, turn the [FILE] knob to find the desired song and press the knob within five seconds to play the file.
- If no control is detected within five seconds, the search is cancelled and the screen displays information about the song currently playing.

### Playing repeatedly

On the control panel, press the [1] button. The repeat play mode changes each time you press it. The corresponding mode icon will be displayed on the screen.

### Playing in random order

On the control panel, press the [2] button. The shuffle play mode is activated or deactivated each time you press it. When you activate the shuffle mode, the corresponding mode icon will be displayed on the screen.

### Searching for music files on a file list

1. On the control panel, press the [3] button to select **List**.
2. Turn the [TUNE] knob to select the desired category and file, and then press the knob to play the music file.

### **i** Information

- Start the engine of your vehicle before connecting a USB device to your system. Starting the engine with a USB device connected to the system may damage the USB device.
- Be careful of static electricity when connecting or disconnecting a USB device. A static discharge may cause a system malfunction.
- Be careful not to let your body or external objects contact the USB port. Doing so may cause an accident or a system malfunction.
- Do not connect and disconnect a USB connector repeatedly in a short time. Doing so may cause an error in the device or a system malfunction.
- Do not use a USB device for purposes other than playing files. Using USB accessories for charging or heating may cause poor performance or a system malfunction.

## NOTICE

- When connecting a USB storage device, do not use an extension cable. Connect it directly to the USB port. If you use a USB hub or an extension cable, the device may not be recognized.
- Fully insert a USB connector into the USB port. Failure to do so may cause a communication error.
- When you disconnect a USB storage device, a distorted noise may occur.
- The system can play only files encoded in a standard format.
- The following types of USB devices may not be recognised or work correctly:
  - Encrypted MP3 players
  - USB devices not recognised as removable disks
- A USB device may not be recognised depending on its condition.
- Some USB devices may be incompatible with your system.

(Continued)

(Continued)

- Depending on the USB device's type, capacity, or the format of files, USB recognition time may be longer.
- Image and video playback are not supported.

## Using the iPod mode

You can listen to music stored on your Apple devices, such as an iPod or an iPhone.

1. Connect your Apple device to the USB port in your vehicle using the cable supplied with the Apple device.
  - When connected, the device will begin charging. Music playback will not start automatically.

2. On the control panel, press the [MEDIA] button.
  - If multiple devices are connected to the system, press the [MEDIA] button and press the [1] button to select iPod from the media selection window.

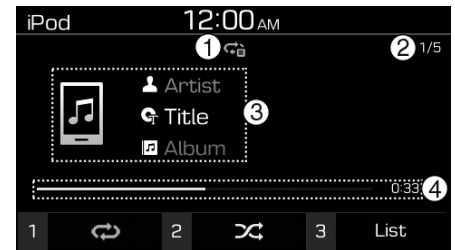

- (1) Repeat play mode
- (2) Current file number and total number of files
- (3) Information about the song currently playing
- (4) Playback time and playback position

Press the [MENU] button on the control panel to access the following menu options:

- **Information:** Display information about the song currently playing.
- **Sound Settings:** Customise the system sound settings.

### ***Rewinding/Fast forwarding***

On the control panel, press and hold the [√ SEEK/TRACK ^] button.

- You can also push and hold the Up/Down lever on the steering wheel.

### ***Restarting the current playback***

On the control panel, press the [√ SEEK/TRACK] button.

- You can also push the Down lever on the steering wheel.

### ***Playing the previous or next song***

To play the previous song, press the [√ SEEK/TRACK] button twice on the control panel. To play the next song, press the [SEEK/TRACK ^] button on the control panel.

- You can also use the Up/Down lever on the steering wheel.

#### **NOTICE**

- **On the control panel, turn the [FILE] knob to find the desired song and press the knob within five seconds to play the file.**
- **If no control is detected within five seconds, the search is cancelled and the screen displays information about the song currently playing.**

### ***Playing repeatedly***

On the control panel, press the [1] button. The repeat play mode changes each time you press it. The corresponding mode icon will be displayed on the screen.

### ***Playing in random order***

On the control panel, press the [2] button. The shuffle play mode is activated or deactivated each time you press it. When you activate the shuffle mode, the corresponding mode icon will be displayed on the screen.

### ***Searching for music files on a file list***

1. On the control panel, press the [3] button to select **List**.
2. Turn the [TUNE] knob to select the desired category and file, and then press the knob to play the music file.

#### ***i* Information**

- **Be sure to start the engine before you connect devices to the system. The device may be damaged if the engine is started while the device connected.**
- **Do not connect and disconnect a USB connector repeatedly in a short time. Doing so may cause an error in the device or a system malfunction.**

### Notes on connecting Apple devices

- Ensure that the iOS and firmware of your device is up-to-date before connecting it to your system. Outdated devices may cause a system error.
- If your device's battery is low, the device may not be recognised. Check the battery level and, if necessary, charge the battery before connecting the device to your system.
- Use an Apple-approved cable. Using an unapproved cable may cause a distorted noise or an error during playback.
- Use a cable shorter than 1 metre in length, such as the one originally supplied with a new Apple device. Longer cables may lead to the audio system not recognising the Apple device.
- Fully insert a USB connector into the USB port. Failure to do so may cause a communication error.

- When your device is connected to the USB port and the AUX port simultaneously, it is recognised in the AUX mode. The device stays in the AUX mode even if the AUX cable is not connected to the system. To play music in iPod mode, disconnect the AUX cable from the device or change audio output of the device to "Dock".
- If you connect your device to the system while playback is in progress on the device, you may hear a high pitch sound just after the connection. Connect the device after stopping or pausing playback.
- Connecting your device during a download or synchronizing with iTunes may cause an error. Connect the device after the download or synchronization is complete.
- If you connect an iPod nano (except for the 6th generation) or an iPod classic, the brand logo will be displayed on the device screen. For an iPhone and an iPod touch, the logo will not be displayed.

### Notes on playing Apple devices

- Depending on the model, your device may not be recognised due to unsupported communication protocols.
- The order of the songs displayed or played on the system may differ from the order of the songs stored in your device.
- Depending on the music player application you are using, information displayed on the system may differ.
- In an iPhone, the audio streaming function and iPod mode control may conflict. If an error occurs, disconnect and reconnect the USB cable.
- When using an iPhone or an iPod touch, do not control the device while it is connected to your system. An error may occur.
- If you make or receive a call during playback via an iPhone, the music may remain paused after you end the call. If you do not hear the music after ending a call, check the device to see if the music is paused.

- Do not duplicate a song in multiple folders. One song saved in multiple folders may cause an error with search and playback functions.
- If you perform a media control function, such as stop or repeat, just before a song ends, the song information displayed on the screen may not match the song currently playing. This is not a system error. Restart the iPod mode on the system or pause and resume playback on your device.
- Skipping or improper operations may occur depending on the characteristics of your Apple device.
- If the Apple device malfunctions due to an Apple device defect, reset the Apple device and try again. (To learn more, refer to your Apple device manual.)

### Using the AUX mode

You can listen to audio from your vehicle's speakers by connecting external devices, such as smartphones and MP3 players.

Connect an external device to the AUX port in your vehicle using an AUX cable.

- The AUX mode starts automatically and the sound is heard via your vehicle's speakers.
- If an external device is already connected to the system, press the [MEDIA] button and press the [3] button to select **AUX** from the media selection window.



Press the [MENU] button on the control panel to access the following a menu option:

- **Sound Settings:** Customise the system sound settings.

### NOTICE

- **Because the system works as an output device of the connected external device in the AUX mode, you cannot use controls other than the volume control. Use controls on the external device to control playback.**
- **The sound volume for the AUX mode is adjusted separately from the other modes.**
- **Depending on the device type, using an external device with the power cable plugged into the power jack may cause a distorted noise.**
- **If the AUX cable is plugged into the system without an external device, a distorted noise may occur. Remove the AUX cable from the AUX port when an external device is not connected.**



## BLUETOOTH

### Connecting Bluetooth devices

Bluetooth is a short-range wireless networking technology. Via Bluetooth, you can connect nearby mobile devices wirelessly to send and receive data between connected devices. This enables you to use your devices effectively.

To use Bluetooth, you must first connect a Bluetooth-enabled device to your system, such as a mobile phone or an MP3 player. Ensure that the device you want to connect supports Bluetooth.

#### WARNING

**Park your vehicle in a safe location before connecting Bluetooth devices. Distracted driving can cause a traffic accident and lead to personal injury or death.**

#### NOTICE

- **On your system, you can use only Bluetooth Handsfree and Audio features. Connect a mobile device that supports both features.**
- **Some Bluetooth devices may cause malfunctions to the audio system or make interference noises. In this case, storing the device in a different location may resolve the problem.**
- **Depending on the connected Bluetooth device or mobile phone, some functions may not be supported.**
- **If the system is not stable due to a vehicle-Bluetooth device communication error, delete the paired devices and connect the Bluetooth devices again.**

(Continued)

(Continued)

- **If Bluetooth connection is not stable, follow these steps to try again.**
  1. **Deactivate Bluetooth and reactivate it on the device. Then, reconnect the device.**
  2. **Turn the device off and on. Then, reconnect it.**
  3. **Remove the battery from the device and reinstall it. Then, turn the device on and reconnect it.**
  4. **Unregister the Bluetooth pairing on both the system and the device and then re-register and connect them.**

### Pairing devices with your system

For Bluetooth connections, first pair your device with your system to add it to the system's list of Bluetooth devices. You can register up to five devices.

1. From the control panel, press the **[SETUP/CLOCK]** button, and then select **Bluetooth ► Connections**.
  - If you are pairing a device with your system for the first time, you can also press the **[PHONE]** button on the control panel or the Call/Answer button on the steering wheel.
2. On the Bluetooth device you want to connect, activate Bluetooth, search for your vehicle's system, and then select it.
  - Check the system's Bluetooth name, which is displayed in the new registration pop-up window on the system screen.

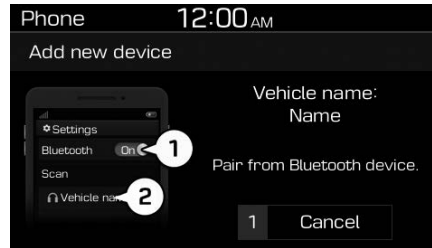

3. Enter or confirm the passkey to confirm the connection.
  - If the passkey input screen is displayed on the Bluetooth device screen, enter the passkey '0000' which is displayed on the system screen.
  - If the 6-digit passkey is displayed on the Bluetooth device screen, ensure that the Bluetooth passkey displayed on the Bluetooth device is the same as the passkey on the system screen and confirm the connection from the device.

4. Choose whether or not to connect the Bluetooth device to your system prior to other devices.

- If you grant priority to the Bluetooth device, it will be connected automatically to the system when you turn on the system.

#### NOTICE

- **The screen image in this manual is an example. Check your system screen for the exact vehicle name and Bluetooth device name.**
- **The default passkey is '0000'.**
- **It may take a while for the system to connect with the device after you permit the system to access the device. When a connection is made, the Bluetooth status icon appears at the top of the screen.**
- **You can change the permission settings via the mobile phone's Bluetooth settings menu. For more details, refer to your mobile phone's user guide.**

(Continued)

(Continued)

- To register a new device, repeat steps 1 to 4.
- When a device is connected to the system via Bluetooth, you cannot pair another device.
- If you use the automatic Bluetooth connection function, a call may be switched to the vehicle's Handsfree when you are taking on the phone near the vehicle while the vehicle's engine is on. If you do not want the system to connect with the device automatically, deactivate Bluetooth on your device.
- When a device is connected to the system via Bluetooth, the device's battery may discharge faster.

### **Connecting a paired device**

To use a Bluetooth device on your system, connect the paired device to the system. Your system can connect with only one device at a time.

1. From the control panel, press the [SETUP/CLOCK] button, and then select **Bluetooth ► Connections**.
  - If there is no connected device, press the [PHONE] button on the control panel or the Call/Answer button on the steering wheel.
2. Turn the [TUNE] knob to select the device to connect, and then press the knob.
  - If another device is already connected to your system, disconnect it. Select the connected device to disconnect.
3. Turn the [TUNE] knob to select **Connect**, and then press the knob.

### **NOTICE**

- If a connection ends because a device is out of the connection range or a device error occurs, the connection will be restored automatically when the device enters the connection range or when the error is cleared.
- The Bluetooth connection is unavailable when the device's Bluetooth function is turned off. Be sure to turn on the device's Bluetooth function.
- Depending on auto connection priority, connection to a device may take time.

### Disconnecting a device

If you want to stop using a Bluetooth device or connect another device, disconnect your currently connected device.

1. From the control panel, press the [SETUP/CLOCK] button, and then select **Bluetooth ► Connections**.
2. Turn the [TUNE] knob to select the device to disconnect, and then press the knob.
3. Turn the [TUNE] knob to select **Disconnect**, and then press the knob.

### Deleting paired devices

If you no longer want a Bluetooth device paired or if you want to connect a new device when the Bluetooth device list is full, delete paired devices.

1. From the control panel, press the [SETUP/CLOCK] button, and then select **Bluetooth ► Connections**.
2. Turn the [TUNE] knob to select the device to delete, and then press the knob.
3. Turn the [TUNE] knob to select **Delete**, and then press the knob.

#### NOTICE

- When you delete a paired device, the Call history and Contacts stored in the system are also deleted.
- To re-use a deleted device, you must pair the device again.

### Using a Bluetooth audio device

You can listen to music stored in the connected Bluetooth audio device via your vehicle's speakers.

On the control panel, press the [MEDIA] button.

- If you have multiple media storage devices, press the [MEDIA] button and press the [2] button to select **BT Audio** from the media selection window.

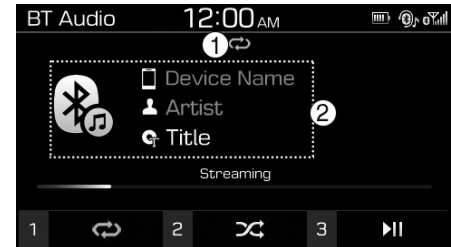

(1) Repeat play mode

(2) Information about the song currently playing

Press the [MENU] button on the control panel to access the following menu options:

- **Connections:** Set up the Bluetooth connection.
- **Sound Settings:** Customise the system sound settings.

### ***Pausing/Resuming playback***

To pause playback, press the [3] button on the control panel. To resume playback, press the [3] button again.

### ***Restarting the current playback***

On the control panel, press the [√ SEEK/TRACK] button.

- You can also push the Down lever on the steering wheel.

### ***Playing the previous or next song***

To play the previous song, press the [√ SEEK/TRACK] button twice on the control panel. To play the next song, press the [SEEK/TRACK ^] button on the control panel.

- You can also use the Up/Down lever on the steering wheel.

#### **NOTICE**

**Depending on the connected Bluetooth device or mobile phone, playing the previous/next song may not be supported.**

### ***Playing repeatedly***

On the control panel, press the [1] button. The repeat play mode changes each time you press it. The corresponding mode icon will be displayed on the screen.

### ***Playing in random order***

On the control panel, press the [2] button. The shuffle play mode is activated or deactivated each time you press it. When you activate the shuffle mode, the corresponding mode icon will be displayed on the screen.

### NOTICE

- Depending on the connected Bluetooth device, mobile phone, or the music player you are using, playback controls may differ.
- Depending on the music player you are using, streaming may not be supported.
- Depending on the connected Bluetooth device or mobile phone, some functions may not be supported.
- If you connect a Bluetooth device or mobile phone to your system via USB and Bluetooth simultaneously the Bluetooth mode is deactivated and music plays in the USB or iPod mode. To listen to music streamed via Bluetooth, remove the USB device.
- If a Bluetooth enabled phone is being used to play music and it receives or makes a phone call, the music will stop.

(Continued)

(Continued)

- Receiving an incoming call or making an outgoing call while playing Bluetooth audio may result in audio interference.
- If you use the Bluetooth phone mode while using Bluetooth audio, playback may not automatically resume after you end the call depending on the connected mobile phone.
- Moving the track up/down while playing Bluetooth audio mode may result in pop noises with some mobile phones.
- The Rewinding/Fast forwarding function is not supported in the Bluetooth audio mode.
- The playlist feature is not supported in the Bluetooth audio mode.
- If the Bluetooth device is disconnected, Bluetooth audio mode will end.

### Using a Bluetooth phone

You can use Bluetooth to talk on the phone hands free. View call information on the system screen, and make or receive calls safely and conveniently via the vehicle's built-in microphone and speakers.

### WARNING

- Park your vehicle in a safe location before connecting Bluetooth devices. Distracted driving can cause a traffic accident and lead to personal injury or death.
- Never dial a phone number or pick up your mobile phone while driving. Use of a mobile phone may distract your attention, making it difficult to recognize external conditions and reducing the ability to cope with unexpected situations, which may lead to an accident. If necessary, use the Bluetooth Handsfree feature to make calls and keep the call as short as possible.

**NOTICE**

- You cannot access the Phone screen if there is no connected mobile phone. To use the Bluetooth phone function, connect a mobile phone to the system.
- The Bluetooth Handsfree function may not work when you are passing out of the cellular service coverage area, such as when you are in a tunnel, underground, or in a mountainous area.
- Call quality may be degraded in the following environments:
  - The reception of the mobile phone is poor
  - The inside of the vehicle is noisy
  - The mobile phone is placed near metallic objects, such as a beverage can
- Depending on the connected mobile phone, the volume and sound quality of the Bluetooth Handsfree may vary.

**Making a call**

If your mobile phone is connected to the system, you can make a call by selecting a name from your call history or contacts list.

1. On the control panel, press the [PHONE] button.
  - Alternatively, press the Call/Answer button on the steering wheel.
2. If you have multiple paired mobile devices, select a mobile phone from your list of paired devices.



3. Select a phone number.
  - To select a phone number from your favourites list, select **Favourites**.
  - To select a phone number from your call history, select **Call history**.
  - To select a phone number from your contacts list that downloaded from the connected mobile phone, select **Contacts**.
4. To end the call, press the [2] button on the control panel to select **End**.
  - Alternatively, press the Call end button on the steering wheel.

### Using the favourites list

- 1 From the Phone screen, press the [1] button to select **Favourites**.
2. Turn the [TUNE] knob to select the desired contact, and then press the knob to make a phone call.

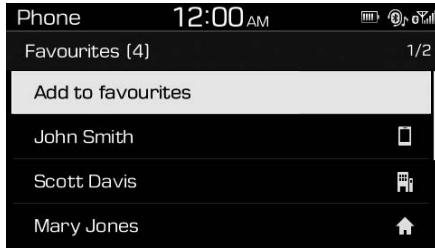

Press the [MENU] button on the control panel to access the following a menu option:

- **Delete:** Delete favourites items.

### NOTICE

- **You can register up to 20 favourites for each device.**
- **You must first download the contacts to the system to register favourites.**
- **The favourites list saved on the mobile phone is not downloaded to the system.**
- **Even if the contact information on the mobile phone is edited, the favourites on the system are not automatically edited. Delete and add the item to favourites again.**
- **When you connect a new mobile phone, your favourites set for the previous mobile phone will not be displayed, but they will remain in your system until you delete the previous phone from the device list.**

### Using your call history

1. From the Phone screen, press the [2] button to select **Call history**.
2. Turn the [TUNE] knob to select the desired entry, and then press the knob to make a phone call.

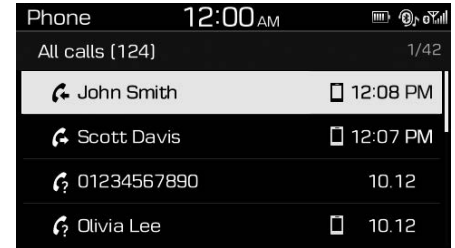

Press the [MENU] button on the control panel to access the following menu options:

- **All calls:** View all call records.
- **Missed calls:** View only missed calls.
- **Dialled calls:** View only dialled calls.
- **Received calls:** View only received calls.
- **Download:** Download your call history.



**NOTICE**

- Some mobile phones may not support the download function.
- The call history is accessed only when the mobile phone is connected to the system.
- Calls from restricted IDs are not saved on the call history list.
- Up to 50 call records will be downloaded per individual list.
- Call duration and time information will not be displayed on the system screen.
- Permission is required to download your call history from the mobile phone. When you attempt to download data, you may need to permit the download on the mobile phone. If the download fails, check the mobile phone screen for any notification or the mobile phone's permission setting.
- When you download your call history, any old data will be deleted.

**Using the contacts list**

1. From the Phone screen, press the [3] button to select **Contacts**.
2. Turn the [TUNE] knob to select the desired group of alphanumeric characters, and then press the knob.
3. Turn the [TUNE] knob to select the desired contact, and then press the knob to make a phone call.



Press the [MENU] button on the control panel to access the following a menu option:

- **Download:** Download your mobile phone contacts.

**NOTICE**

- **Contacts can be downloaded only from the currently connected Bluetooth device.**
- **Contacts can be viewed only when the Bluetooth device is connected.**
- **Only contacts in the supported format can be downloaded and displayed from the Bluetooth device. Contacts from some applications will not be included.**
- **Up to 2,000 contacts can be downloaded from your device.**
- **Some mobile phones may not support the download function.**
- **Depending on the system's specifications, some of the downloaded contacts may be lost.**
- **Contacts stored both in the phone and in the SIM card are downloaded. With some mobile phones, contacts in the SIM card may not be downloaded.**

(Continued)

(Continued)

- **Special characters and figures used in the contact name may not be displayed properly.**
- **Permission is required to download contacts from the mobile phone. When you attempt to download data, you may need to permit the download on the mobile phone. If the download fails, check the mobile phone screen for any notification or the mobile phone's permission setting.**
- **Depending on the mobile phone type or status, downloading may take longer.**
- **When you download your contacts, any old data will be deleted.**
- **You cannot edit or delete your contacts on the system.**
- **When you connect a new mobile phone, your contacts downloaded from the previous mobile phone will not be displayed, but they will remain in your system until you delete the previous phone from the device list.**

### Answering calls

When a call comes in, a notification pop-up window of the incoming call appears on the system screen.



To answer the call, press the [1] button on the control panel to select **Accept**.

- Alternatively, press the Call/Answer button on the steering wheel.

To reject the call, press the [2] button on the control panel to select **Reject**.

- Alternatively, press the Call end button on the steering wheel.

### NOTICE

- **Depending on the mobile phone type, call rejection may not be supported.**
- **Once your mobile phone is connected to the system, the call sound may be output through the vehicle's speakers even after you exit the vehicle if the phone is within the connection range. To end the connection, disconnect the device from the system or deactivate Bluetooth on the device.**

### Using options during a call

During a call, you will see the call screen shown below. Press a button to perform the function you want.

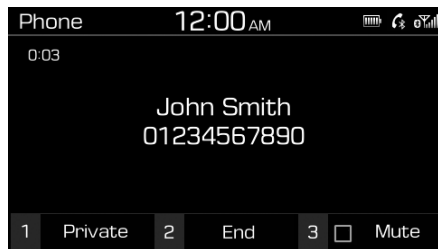

To switch the call to your mobile phone, press the [1] button on the control panel to select **Private**.

- Alternatively, press and hold the Call/Answer button on the steering wheel.

To end the call, press the [2] button on the control panel to select **End**.

- Alternatively, press the Call end button on the steering wheel.

Press the [MENU] button on the control panel to access the following a menu option:

- **Microphone Volume (Outgoing Volume):** Adjust the microphone volume or turn off the microphone so the other party cannot hear you.

### NOTICE

- If the caller information is saved in your contacts list, the caller's name and phone number will be displayed. If the caller information is not saved in your contacts list, only the caller's phone number will be displayed.
- You cannot switch to any other screen, such as the audio screen or the settings screen, during a Bluetooth call.
- Depending on the mobile phone type, call quality may vary. On some phones, your voice may be less audible to the other party.
- Depending on the mobile phone type, the phone number may not be displayed.
- Depending on the mobile phone type, the call switching function may not be supported.

### SETUP

#### Display

You can change the settings related to the system display.

On the control panel, press the [SETUP/CLOCK] ► [1] buttons to select **Display**.

- **Dimming mode (Mode)**: Set the screen brightness to be adjusted automatically according to the headlight use or set the screen to stay bright or dark continuously.
- **Brightness (Illumination)**: Adjust the brightness for the day or night mode according to your setting in the **Dimming mode (Mode)** option.
- **Screensaver**: Select a screen saver option to be displayed when the system is turned off.
- **Scroll text (Text Scroll)** (if equipped): Set to scroll text when information text is too long to display all on the screen.

#### NOTICE

**The text scroll function (if equipped) is only available in the following situation:**

- **When displaying titles in the USB/iPod/Bluetooth audio modes.**

#### Sound

You can change the settings related to sounds, such as location where sound will be concentrated and the output level for each range.

On the control panel, press the [SETUP/CLOCK] ► [2] buttons to select **Sound**.

- **Position**: Select a location where sound will be concentrated in the vehicle. Select **Fade (Fader)** or **Balance**, turn the [TUNE] knob to select the desired position, and then press the knob. To set sound to be centred in the vehicle, select **Centre**.
- **Equaliser (Tone)**: Adjust the output level for each sound tone mode.

- **Speed dependent volume control (Speed Dependent Volume)**: Set the volume to be adjusted automatically according to your driving speed.
- **Rear parking sensors prioritised (Back-up Warning Priority)**: Set to decrease the audio volume to hear a reverse warning prior to other sounds while reversing your vehicle.

#### NOTICE

- **Depending on vehicle models or specifications, available options may vary.**
- **Depending on the system or amplifier specifications applied to your vehicle, available options may vary.**

## Date/Time

You can change the date and time that are shown on the system display.

On the control panel, press the [SETUP/CLOCK] ► [3] buttons to select **Date/Time**.

- **Set date:** Set date to display on the system display.
- **Set time:** Set time to display on the system display.
- **Time format:** Select to display time in the 12 hour format or the 24 hour format.

## Bluetooth

You can change the settings for Bluetooth connections.

On the control panel, press the [SETUP/CLOCK] ► [4] buttons to select **Bluetooth**.

- **Connections:** Pair new Bluetooth devices with your system, or connect or disconnect a paired device. You can also delete paired devices.
- **Auto connection priority:** Select a paired device to connect to your system automatically when it turns on.
- **Update contacts (Download Contacts):** Download the contacts list from the connected mobile phone.
- **Bluetooth voice guidance** (if equipped): Turn on or off the voice guidance for Bluetooth pairing, connection, and errors.

### NOTICE

- If no Bluetooth device is connected, the Update contacts (Download Contacts) menu is disabled.
- If the system language is selected to Slovakian or Hungarian, Bluetooth voice guidance menu is disabled.

## System

You can change the display language or initialise system settings.

On the control panel, press the [SETUP/CLOCK] ► [5] buttons to select **System**.

- **Language:** Change the display language.
- **Default:** Reset your system settings to the default values. All user data stored in the system will also be deleted.

## SYSTEM STATUS ICONS

Status icons appear at the top of the screen to display the current system status.



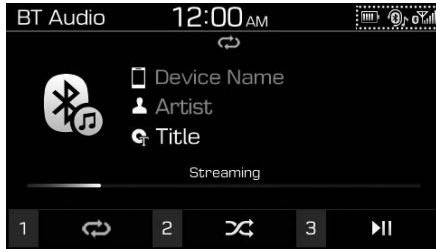





Familiarise yourself with the status icons that appear when you perform certain actions or functions and their meanings.



### Mute

Icon	Description
	Audio muted

### Bluetooth

Icon	Description
	Battery level of connected Bluetooth device
	Mobile phone connected via Bluetooth
	Audio device connected via Bluetooth
	Mobile phone and audio device connected via Bluetooth
	Bluetooth call in progress
	Microphone turned off during Bluetooth call
	Downloading call history from a mobile phone connected via Bluetooth to the system
	Downloading contacts from a mobile phone connected via Bluetooth to the system

### Signal strength

Icon	Description
	Signal strength of the mobile phone connected via Bluetooth

### NOTICE

- The battery level displayed on the screen may differ from the battery level displayed on the connected device.
- The signal strength displayed on the screen may differ from the signal strength displayed on the connected mobile phone.
- Depending on vehicle models and specifications, some status icons may not be displayed.

## AUDIO SYSTEM SPECIFICATIONS

### USB

#### **Supported audio formats**

- Audio file specification
  - WAVeform audio format
  - MPEG1/2/2.5 Audio Layer3
  - Windows Media Audio Ver 7.X/8.X
- Bit rates
  - MPEG1 (Layer3): 32/40/48/56/64/80/96/112/128/160/192/224/256/320 kbps
  - MPEG2 (Layer3): 8/16/24/32/40/48/56/64/80/96/112/128/144/160 kbps
  - MPEG2.5 (Layer3): 8/16/24/32/40/48/56/64/80/96/112/128/144/160 kbps
  - WMA (High Range): 48/64/80/96/128/160/192 kbps
- Bits Per Sample
  - WAV (PCM(Stereo)): 24 bit
  - WAV (IMA ADPCM): 4 bit
  - WAV (MS ADPCM): 4 bit
- Sampling frequency
  - MPEG1: 44100/48000/32000 Hz
  - MPEG2: 22050/24000/16000 Hz
  - MPEG2.5: 11025/12000/8000 Hz
  - WMA: 32000/44100/48000 Hz
  - WAV: 44100/48000 Hz
- Maximum number of directory layers: No limitation
- Maximum length of folder names (Based on Unicode): 31 English or Korean characters
- Maximum length of file names (Based on Unicode): 63 English or Korean characters
- Supported characters for folder/file names (Unicode support): 2,604 Korean characters, 94 alphanumeric characters, 4,888 Chinese characters in common use, 986 special characters
- Maximum number of folders: 2,000
- Maximum number of files: 6,000

### **NOTICE**

- **Files that are not in a supported format may not be recognised or played, or information about them, such as the file name, may not be displayed properly.**
- **Only files with .mp3/.wma/.wav extensions can be recognised by the system. If the file is not in supported format, change the file format by using the latest encoding software.**
- **The device will not support files locked by DRM (Digital Rights Management).**
- **For MP3/WMA compression files and WAV file, differences in sound quality will occur depending on the bitrate. (Music files with a higher bitrate have a better sound quality.)**
- **Japanese or Simplified Chinese characters in folder or file names may not be displayed properly.**

### **Supported USB storage devices**

- Byte/Sector: 64 kbyte or less
- Format system: FAT12/16/32 (recommended)
- Maximum device size: 32 GB

#### **NOTICE**

- **Operation is guaranteed only for a metal cover type USB storage device with a plug type connector.**
  - **USB storage devices with a plastic plug may not be recognised.**
  - **USB storage devices in memory card types, such as CF card or SD cards, may not be recognised.**
- **USB hard disk drives may not be recognised.**
- **When you use a large capacity USB storage device with multiple logical drives, only files stored on the first drive will be recognised.**

(Continued)

(Continued)

- **If an application program is loaded on a USB storage device, the corresponding media files may not play.**
- **Use USB 2.0 devices for better compatibility.**

### **Bluetooth**

- Bluetooth Power Class 2:  
-6 to 4 dBm
- Aerial power: Max 3 mW
- Frequency range: 2400 to 2483.5 MHz
- Bluetooth patch RAM software version: 1



---

## TRADEMARKS

Other trademarks and trade names are those of their respective owners.

- The Bluetooth® word mark and logos are registered trademarks owned by Bluetooth SIG, Inc. and any use of such marks by HYUNDAI is under licence. 
- Apple®, iPad®, iPad mini™, iPhone®, iPod®, iPod classic®, iPod nano®, iPod touch®, and iTunes® are a registered trademark of Apple Inc.

# DECLARATION OF CONFORMITY

## CE RED for EU

<b>EU Declaration of Conformity</b> <sup>(1)</sup>		<b>HYUNDAI MOBIS</b>	
<b>Product details</b> <sup>(2)</sup>			
<b>Product</b> <sup>(3)</sup>	DIGITAL CAR AUDIO SYSTEM		
<b>Model</b> <sup>(4)</sup>	ACBC1D7EE, ACB10D3GG, ACB10D3GN, ACB10D3GL, ACB10D3MG, ACB10D3MN, ACB10D3EG, ACB10D3EE, ACB11D3EE, ACB10D3BB, ACB10D7FH, ACB10D7EG		
We hereby declare, that the product above is in compliance with the essential requirements of the Directive 2014/53/EU by application of <sup>(5)</sup>			
<b>Applied Standards</b> <sup>(6)</sup>			
<b>Article</b> <sup>(7)</sup> <b>3.2</b> Radio <sup>(8)</sup>	EN 300 328 V2.1.1, Draft EN 303 345 V1.1.7		
<b>Article</b> <sup>(7)</sup> <b>3.1b</b> EMC <sup>(9)</sup>	EN 301 489-1 V2.1.1, Draft EN 301 489-3 V2.1.1, EN 301 489-17 V3.1.1, EN 55013:2013, EN 55032:2015, EN 55020:2007/A11:2011		
<b>Article</b> <sup>(7)</sup> <b>3.1a</b> Safety <sup>(10)</sup> , Health <sup>(11)</sup>	EN 60665:2014, EN 62311:2008		
<b>Manufacturer</b> <sup>(12)</sup>		<b>Representative in the EU</b> <sup>(13)</sup>	
HYUNDAI MOBIS Co., Ltd.		MOBIS Parts Europe N.V.	
203, Teheran-ro, Gangnam-gu,		Wilhelm-Fay-Strabe 51,	
Seoul, 135-977, Korea		Frankfurt Main, 65936, Germany	
Tel: +82-31-260-0098		Tel: +49-69-85096-5011	
<b>Notified Body</b> <sup>(14)</sup>		<b>Signed By</b> <sup>(15)</sup> 20/11/2017	
MICOM Labs Inc,		This declaration of conformity is issued under the sole responsibility of the manufacturer. <sup>(16)</sup>	
California 94566, USA		 Seunghoon Choe Representative Hyundai MOBIS Co., Ltd.	
575 Boulder Court, Pleasanton			
<b>Additional information</b> <sup>(17)</sup>			
SW: 1.0, HW: 1.0			

## FCC

This equipment has been tested and found to comply with the limits for a Class B digital device, pursuant to part 15 of the FCC Rules. These limits are designed to provide reasonable protection against harmful interference in a residential installation.

This equipment generates, uses and can radiate radio frequency energy and, if not installed and used in accordance with the instructions, may cause harmful interference to radio communications. However, there is no guarantee that interference will not occur in a particular installation. If this equipment does cause harmful interference to radio or television reception, which can be determined by turning the equipment off and on, the user is encouraged to try to correct the interference by one or more of the following measures:

- Reorient or relocate the receiving antenna.
- Increase the separation between the equipment and receiver.
- Connect the equipment into an outlet on a circuit different from that to which the receiver is connected.
- Consult the dealer or an experienced radio/TV technician for help

This device complies with part 15 of the FCC Rules. Operation is subject to the following two conditions: (1) This device may not cause harmful interference, and (2) this device must accept any interference received, including interference that may cause undesired operation.

Caution: Any changes or modifications to this device not expressly approved by the party responsible for compliance could void your authority to operate the equipment.

This equipment complies with FCC radiation exposure limits set forth for an uncontrolled environment.

This equipment should be installed and operated with minimum 20 cm between the radiator and your body. This transmitter must not be collocated or operating in conjunction with any other antenna or transmitter unless authorized to do so by the FCC.

### **IFETEL for Mexico**

“La operación de este equipo está sujeta a las siguientes dos condiciones: (1) es posible que este equipo o dispositivo no cause interferencia perjudicial y (2) este equipo o dispositivo debe aceptar cualquier interferencia, incluyendo la que pueda causar su operación no deseada.”

## Driving your vehicle

<b>Before driving</b> .....	5-5	<b>Braking system</b> .....	5-43
Before entering the vehicle .....	5-5	Power brakes .....	5-43
Before starting .....	5-5	Disc brakes wear indicator .....	5-44
<b>Ignition switch</b> .....	5-6	Parking brake (hand type).....	5-44
Key ignition switch.....	5-6	Electronic Parking Brake (EPB) .....	5-46
Engine Start/Stop button.....	5-11	AUTO HOLD .....	5-52
<b>Manual transaxle</b> .....	5-20	Anti-lock Brake System (ABS) .....	5-56
Manual transaxle operation .....	5-20	Electronic Stability Control (ESC) .....	5-58
Good driving practices .....	5-22	Vehicle Stability Management.....	5-62
<b>Automatic transaxle</b> .....	5-24	Hill-Start Assist Control (HAC) .....	5-63
Automatic transaxle operation .....	5-24	Downhill Brake Control (DBC) .....	5-64
Parking.....	5-29	Low Vacuum Assist (LVA).....	5-66
Good driving practices .....	5-29	Emergency Stop Signal (ESS) .....	5-66
<b>Dual clutch transmission</b> .....	5-31	Good braking practices .....	5-67
Dual clutch transmission operation .....	5-31	<b>Four wheel drive (4WD)</b> .....	5-67
LCD display for transmission temperature and warning message.....	5-33	4WD operation .....	5-69
Parking.....	5-41	Emergency precautions.....	5-73
Good driving practices .....	5-41	Reducing the risk of a rollover .....	5-74
		<b>ISG (Idle Stop and Go) system</b> .....	5-76
		To activate the ISG system.....	5-76
		To deactivate the ISG system .....	5-80
		ISG system malfunction.....	5-80
		The battery sensor deactivation.....	5-81

Flex steering wheel .....	5-82
Drive Mode Integrated Control System .....	5-84
Forward collision-avoidance assist (FCA) system - sensor fusion type (front radar + front camera) (Except Middle East) .....	5-85
System setting and activation .....	5-85
FCA warning message and system control .....	5-87
FCA sensor .....	5-90
System malfunction .....	5-92
Limitations of the system .....	5-94
Forward collision-avoidance assist (FCA) system - sensor fusion type (front radar + front camera) (For Middle East) .....	5-100
System setting and activation .....	5-100
FCA warning message and system control .....	5-102
FCA sensor .....	5-105
System malfunction .....	5-107
Limitations of the system .....	5-109
Blind-spot collision warning (BCW) system ..	5-114
BCW .....	5-115
RCCW (Rear Cross-Traffic Collision Warning) .....	5-117
Detecting sensor .....	5-119
Limitations of the system .....	5-120
Lane keeping assist (LKA) system (For Europe) .....	5-122
LKA operation .....	5-123
Warning light and message .....	5-128
Limitations of the System .....	5-129
LKA system function change .....	5-130
Lane keeping assist (LKA) system (Except Europe) .....	5-131
LKA operation .....	5-132
Warning light and message .....	5-137
Limitations of the System .....	5-138
LKA system function change .....	5-140
Driver attention warning (DAW) system .....	5-141
System setting and activation .....	5-141
Resetting the system .....	5-142
System standby .....	5-143
System malfunction .....	5-143
Speed limit control system .....	5-146
Speed Limit Control Operation .....	5-146
Intelligent speed limit warning (ISLW) system ..	5-148
System setting and activation .....	5-149
Display .....	5-150
Limitations of the system .....	5-152
Driver's attention .....	5-153

<b>Cruise control (With Speed Limit Control).....</b>	<b>5-154</b>
Cruise Control Operation .....	5-154
<b>Cruise control.....</b>	<b>5-159</b>
Cruise Control operation.....	5-159
<b>Smart cruise control with stop &amp; go system.</b>	<b>5-166</b>
Smart Cruise Control Switch .....	5-166
Smart Cruise Control speed.....	5-167
Smart Cruise Control Vehicle-to-Vehicle Distance.....	5-173
Sensor to detect distance to the vehicle ahead .....	5-176
To adjust the sensitivity of Smart Cruise Control.....	5-178
To convert to Cruise Control mode.....	5-179
Limitations of the system.....	5-179
<b>Special driving conditions.....</b>	<b>5-184</b>
Hazardous driving conditions .....	5-184
Rocking the vehicle .....	5-184
Smooth cornering .....	5-185
Driving at night.....	5-185
Driving in the rain.....	5-185
Driving in flooded areas.....	5-186
Highway driving.....	5-186
Reducing the risk of a rollover .....	5-187
<b>Winter driving.....</b>	<b>5-188</b>
Snow or icy conditions.....	5-188
Winter Precautions.....	5-190

<b>Trailer towing (For Europe) .....</b>	<b>5-193</b>
If you decide to pull a trailer?.....	5-194
Trailer towing equipment.....	5-198
Driving with a trailer .....	5-199
Maintenance when towing a trailer.....	5-203
<b>Vehicle weight .....</b>	<b>5-204</b>
Overloading .....	5-204

 **WARNING**

**Carbon monoxide (CO) gas is toxic. Breathing CO can cause unconsciousness and death.**

Engine exhaust contains carbon monoxide which cannot be seen or smelled.

**Do not inhale engine exhaust.**

If at any time you smell engine exhaust inside the vehicle, open the windows immediately. Exposure to CO can cause unconsciousness and death by asphyxiation.

**Be sure the exhaust system does not leak.**

The exhaust system should be checked whenever the vehicle is raised to change the oil or for any other purpose. If you hear a change in the sound of the exhaust or if you drive over something that strikes the underneath side of the vehicle, we recommend that the exhaust system be checked as soon as possible by an authorized HYUNDAI dealer.

**Do not run the engine in an enclosed area.**

Letting the engine idle in your garage, even with the garage door open, is a hazardous practice. Run the engine only long enough to start the engine and to move the vehicle out of the garage.

**Avoid idling the engine for prolonged periods with people inside the vehicle.**

If it is necessary to idle the engine for a prolonged period with people inside the vehicle, be sure to do so only in an open area with the air intake set at "Fresh" and fan control set to high so fresh air is drawn into the interior.

**Keep the air intakes clear.**

To assure proper operation of the ventilation system, keep the ventilation air intakes located in front of the windshield clear of snow, ice, leaves, or other obstructions.

**If you must drive with the tailgate open:**

Close all windows.

Open instrument panel air vents.

Set the air intake control at "Fresh", the air flow control at "Floor" or "Face", and the fan control set to high.



## BEFORE DRIVING

### Before entering the vehicle

- Be sure all windows, outside mirror(s), and outside lights are clean and unobstructed.
- Remove frost, snow, or ice.
- Visually check the tires for uneven wear and damage.
- Check under the vehicle for any sign of leaks.
- Be sure there are no obstacles behind you if you intend to back up.

### Before starting

- Make sure the hood, the trunk, and the doors are securely closed and locked.
- Adjust the position of the seat and steering wheel.
- Adjust the inside and outside rearview mirrors.
- Verify all the lights work.
- Fasten your seatbelt. Check that all passengers have fastened their seatbelts.
- Check the gauges and indicators in the instrument panel and the messages on the instrument display when the ignition switch is in the ON position.

- Check that any items you are carrying are stored properly or fastened down securely.

### WARNING

To reduce the risk of **SERIOUS INJURY or DEATH**, take the following precautions:

- **ALWAYS** wear your seat belt. All passengers must be properly belted whenever the vehicle is moving. For more details, refer to “Seat Belts” in chapter 2.
- **Always** drive defensively. Assume other drivers or pedestrians may be careless and make mistakes.
- **Stay focused** on the task of driving. Driver distraction can cause accidents.
- **Leave plenty of space** between you and the vehicle in front of you.

### WARNING

**NEVER** drink or take drugs and drive.

Drinking or taking drugs and driving is dangerous and may result in an accident and **SERIOUS INJURY or DEATH**.

Drunk driving is the number one contributor to the highway death toll each year. Even a small amount of alcohol will affect your reflexes, perceptions and judgment. Just one drink can reduce your ability to respond to changing conditions and emergencies and your reaction time gets worse with each additional drink.

Driving while under the influence of drugs is as dangerous or more dangerous than driving under the influence of alcohol.

You are much more likely to have a serious accident if you drink or take drugs and drive. If you are drinking or taking drugs, don't drive. Do not ride with a driver who has been drinking or taking drugs. Choose a designated driver or call a taxi.

## IGNITION SWITCH

### **⚠ WARNING**

To reduce the risk of **SERIOUS INJURY** or **DEATH**, take the following precautions:

- **NEVER** allow children or any person who is unfamiliar with the vehicle to touch the ignition switch or related parts. Unexpected and sudden vehicle movement can occur.
- **NEVER** reach through the steering wheel for the ignition switch, or any other control, while the vehicle is in motion. The presence of your hand or arm in this area may cause a loss of vehicle control resulting in an accident.

### Key ignition switch

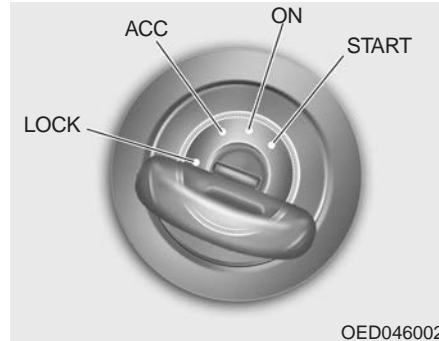

### **⚠ WARNING**

- **NEVER** turn the ignition switch to the **LOCK** or **ACC** position while the vehicle is in motion except in an emergency. This will result in the engine turning off and loss of power assist for the steering and brake systems. This may lead to loss of directional control and braking function, which could cause an accident.

(Continued)

(Continued)

- Before leaving the driver's seat, always make sure the shift lever is in 1st gear (for manual transaxle vehicle) or P (Park, for automatic transaxle /dual clutch transmission vehicle) position, apply the parking brake, and turn ignition switch to the **LOCK** position.

Unexpected vehicle movement may occur if these precautions are not followed.

## Key ignition switch positions

Switch Position	Action	Notes
<b>LOCK</b>	<p>To turn the ignition switch to the LOCK position, push the key in slightly at the ACC position and turn the key towards the LOCK position.</p> <p>The ignition key can be removed in the LOCK position.</p> <p>The steering wheel locks to protect the vehicle from theft. (if equipped)</p>	
<b>ACC</b>	<p>Electrical accessories are usable.</p> <p>The steering wheel unlocks.</p>	<p>If difficulty is experienced turning the ignition switch to the ACC position, turn the key while turning the steering wheel right and left to release tension.</p>
<b>ON</b>	<p>This is the normal key position when the engine has started.</p> <p>All features and accessories are usable.</p> <p>The warning lights can be checked when you turn the ignition switch from ACC to ON.</p>	<p>Do not leave the ignition switch in the ON position when the engine is not running to prevent the battery from discharging.</p>
<b>START</b>	<p>To start the engine, turn the ignition switch to the START position.</p> <p>The switch returns to the ON position when you let go of the key.</p>	<p>The engine will crank until you release the key.</p>

## Starting the engine

### WARNING

- **Always wear appropriate shoes when operating your vehicle. Unsuitable shoes, such as high heels, ski boots, sandals, flip-flops, etc., may interfere with your ability to use the brake, accelerator and clutch pedals.**
- **Do not start the vehicle with the accelerator pedal depressed. The vehicle can move and lead to an accident.**
- **Wait until the engine rpm is normal. The vehicle may suddenly move if the brake pedal is released when the rpm is high.**

## Starting the gasoline engine

Vehicle with manual transaxle:

1. Make sure the parking brake is applied.
2. Make sure the shift lever is in neutral.
3. Depress the clutch and brake pedals.
4. Turn the ignition switch to the START position. Hold the key (maximum of 10 seconds) until the engine starts and release it.

Vehicle with automatic transaxle/dual clutch transmission:

1. Make sure the parking brake is applied.
2. Make sure the shift lever is in P (Park).
3. Depress the brake pedal.
4. Turn the ignition switch to the START position. Hold the key (maximum of 10 seconds) until the engine starts and release it.

## **i** Information

- **Do not wait for the engine to warm up while the vehicle remains stationary.**



**Start driving at moderate engine speeds. (Steep accelerating and decelerating should be avoided.)**

- **Always start the vehicle with your foot on the brake pedal. Do not depress the accelerator while starting the vehicle. Do not race the engine while warming it up.**



### Starting the diesel engine

To start the diesel engine when the engine is cold, it has to be pre-heated before starting the engine and then have to be warmed up before starting to drive.

Vehicle with manual transaxle:

1. Make sure the parking brake is applied.
2. Make sure the shift lever is in neutral.
3. Depress the clutch and brake pedals.
4. Turn the ignition switch to the ON position to pre-heat the engine. The glow indicator light (  ) will illuminate.
5. When the glow indicator light (  ) goes out, turn the key ignition switch to the START position. Hold the key (maximum of 10 seconds) until the engine starts and release it.

Vehicle with automatic transaxle:

1. Make sure the parking brake is applied.
2. Make sure the shift lever is in P (Park).
3. Depress the brake pedal.
4. Turn the ignition switch to the ON position to pre-heat the engine. The glow indicator light (  ) will illuminate.
5. When the glow indicator light (  ) goes out, turn the key ignition switch to the START position. Hold the key (maximum of 10 seconds) until the engine starts and release it.

### **NOTICE**

**If the engine does not start within 10 seconds after preheating is completed, turn the ignition switch once more to the LOCK position and wait for 10 seconds. Then turn the ignition switch to the ON position in order to pre-heat the engine again.**

### Starting and stopping the engine for turbocharger intercooler

1. Do not race or accelerate the engine immediately after starting the engine.

If the engine is cold, idle for several seconds before sufficient lubrication is ensured in the turbo charger unit.

2. After high speed or extended driving that requires heavy engine load, idle the engine about 1 minute before turning the engine off.

This idle time will allow the turbocharger to cool prior to shutting the engine off.

#### **NOTICE**

**Do not turn off the engine immediately after it has been subjected to a heavy load. Doing so may cause severe damage to the engine or turbo charger unit.**

#### **NOTICE**

**To prevent damage to the vehicle:**

- **Do not hold the ignition key in the START position for more than 10 seconds. Wait 5 to 10 seconds before trying again.**
- **Do not turn the ignition switch to the START position with the engine running. It may damage the starter.**
- **If traffic and road conditions permit, you may put the shift lever in the N (Neutral) position while the vehicle is still moving and turn the ignition switch to the START position in an attempt to restart the engine.**
- **Do not push or tow your vehicle to start the engine.**

## Engine Start/Stop button



Whenever the front door is opened, the Engine Start/Stop button will illuminate and will go off 30 seconds after the door is closed.

### **⚠ WARNING**

To turn the engine off in an emergency:

Press and hold the Engine Start/Stop button for more than two seconds OR Rapidly press and release the Engine Start/Stop button three times (within three seconds).



If the vehicle is still moving, you can restart the engine without depressing the brake pedal by pressing the Engine Start/Stop button with the shift lever in the N (Neutral) position.

### **⚠ WARNING**

- **NEVER** press the Engine Start/Stop button while the vehicle is in motion except in an emergency. This will result in the engine turning off and loss of power assist for the steering and brake systems. This may lead to loss of directional control and braking function, which could cause an accident.
- Before leaving the driver's seat, always make sure the shift lever is in the P (Park) position, set the parking brake, press the Engine Start/Stop button to the OFF position, and take the Smart Key with you. Unexpected vehicle movement may occur if these precautions are not followed.



### Engine Stop/Start button positions

#### - Vehicle with manual transaxle

Button Position	Action	Notes
<p data-bbox="212 288 268 311"><b>OFF</b></p>  <p>The image shows a circular button with 'OFF', 'ACC', and 'ON' markings around the perimeter. The 'OFF' marking is highlighted in white, and the central text reads 'ENGINE START STOP'.</p>	<p data-bbox="384 294 895 350">To turn off the engine, stop the vehicle and then press the Engine Start/Stop button.</p> <p data-bbox="384 359 911 415">The steering wheel locks to protect the vehicle from theft. (if equipped)</p>	<p data-bbox="935 294 1468 372">If the steering wheel is not locked properly when you open the driver's door, the warning chime will sound.</p>
<p data-bbox="212 592 268 614"><b>ACC</b></p>  <p>The image shows the same circular button as above, but the 'ACC' marking is highlighted in blue, and the central text reads 'ENGINE START STOP'.</p>	<p data-bbox="384 598 874 676">Press the Engine Start/Stop button when the button is in the OFF position without depressing the clutch pedal.</p> <p data-bbox="384 685 783 713">Electrical accessories are usable.</p> <p data-bbox="384 722 719 750">The steering wheel unlocks.</p>	<p data-bbox="935 598 1468 710">If you leave the Engine Start/Stop button in the ACC position for more than one hour, the battery power will turn off automatically to prevent the battery from discharging.</p> <p data-bbox="935 719 1461 853">If the steering wheel doesn't unlock properly, the Engine Start/Stop button will not work. Press the Engine Start/Stop button while turning the steering wheel right and left to release tension.</p>





- Vehicle with manual transaxle



Button Position	Action	Notes
<p data-bbox="220 260 260 283"><b>ON</b></p> 	<p data-bbox="384 266 893 348">Press the Engine Start/Stop button while it is in the ACC position without depressing the clutch pedal.</p> <p data-bbox="384 359 879 412">The warning lights can be checked before the engine is started.</p>	<p data-bbox="935 266 1461 348">Do not leave the Engine Start/Stop button in the ON position when the engine is not running to prevent the battery from discharging.</p>
<p data-bbox="196 563 284 585"><b>START</b></p> 	<p data-bbox="384 568 893 650">To start the engine, depress the clutch and brake pedals and press the Engine Start/Stop button with the shift lever in neutral.</p>	<p data-bbox="935 568 1422 680">If you press the Engine Start/Stop button without depressing the clutch pedal, the engine does not start and the Engine Start/Stop button changes as follows:</p> <p data-bbox="935 686 1366 714"><b>OFF → ACC → ON → OFF or ACC</b></p>

### Engine Stop/Start button positions

#### - Vehicle with automatic transaxle / dual clutch transmission

Button Position	Action	Notes
<p style="text-align: center;"><b>OFF</b></p> 	<p>To turn off the engine, press the Engine Start/Stop button with shift lever in P (Park). When you press the Engine Start/Stop button without the shift lever in P (Park), the Engine Start/Stop button does not turn to the OFF position, but turns to the ACC position.</p> <p>The steering wheel locks to protect the vehicle from theft. (if equipped)</p>	<p>If the steering wheel is not locked properly when you open the driver's door, the warning chime will sound.</p>
<p style="text-align: center;"><b>ACC</b></p> 	<p>Press the Engine Start/Stop button when the button is in the OFF position without depressing the brake pedal.</p> <p>Electrical accessories are usable.</p> <p>The steering wheel unlocks.</p>	<p>If you leave the Engine Start/Stop button in the ACC position for more than one hour, the battery power will turn off automatically to prevent the battery from discharging.</p> <p>If the steering wheel doesn't unlock properly, the Engine Start/Stop button will not work. Press the Engine Start/Stop button while turning the steering wheel right and left to release tension.</p>

- Vehicle with automatic transaxle / dual clutch transmission

Button Position	Action	Notes
<p style="text-align: center;"><b>ON</b></p> 	<p>Press the Engine Start/Stop button while it is in the ACC position without depressing the brake pedal.</p> <p>The warning lights can be checked before the engine is started.</p>	<p>Do not leave the Engine Start/Stop button in the ON position when the engine is not running to prevent the battery from discharging.</p>
<p style="text-align: center;"><b>START</b></p> 	<p>To start the engine, depress the brake pedal and press the Engine Start/Stop button with the shift lever in the P (Park) or in the N (Neutral) position.</p> <p>For your safety, start the engine with the shift lever in the P (Park) position.</p>	<p>If you press the Engine Start/Stop button without depressing the brake pedal, the engine does not start and the Engine Start/Stop button changes as follows:  <b>OFF → ACC → ON → OFF or ACC</b></p>

## Starting the engine

### WARNING

- Always wear appropriate shoes when operating your vehicle. Unsuitable shoes, such as high heels, ski boots, sandals, flip-flops, etc., may interfere with your ability to use the brake, accelerator and clutch pedals.
- Do not start the vehicle with the accelerator pedal depressed. The vehicle can move and lead to an accident.
- Wait until the engine rpm is normal. The vehicle may suddenly move if the brake pedal is released when the rpm is high.

### Information

- The engine will start by pressing the Engine Start/Stop button, only when the smart key is in the vehicle.
- Even if the smart key is in the vehicle, if it is far away from the driver, the engine may not start.
- When the Engine Start/Stop button is in the ACC or ON position, if any door is open, the system checks for the smart key. If the smart key is not in the vehicle, the " " indicator will blink and the warning "Key not in vehicle" will come on, and if all doors are closed, the chime will also sound for about 5 seconds. Keep the smart key in the vehicle when using the ACC position or if the vehicle engine is ON.

## Starting the gasoline engine

Vehicle with manual transaxle:

1. Always carry the smart key with you.
2. Make sure the parking brake is applied.
3. Make sure the shift lever is in neutral.
4. Depress the clutch and brake pedals.
5. Press the Engine Start/Stop button.

Vehicle with automatic transaxle/dual clutch transmission:

1. Always carry the smart key with you.
2. Make sure the parking brake is applied.
3. Make sure the shift lever is in P (Park).
4. Depress the brake pedal.
5. Press the Engine Start/Stop button.

## **i** Information

- **Do not wait for the engine to warm up while the vehicle remains stationary.**



**Start driving at moderate engine speeds. (Steep accelerating and decelerating should be avoided.)**

- **Always start the vehicle with your foot on the brake pedal. Do not depress the accelerator while starting the vehicle. Do not race the engine while warming it up.**



### Starting the diesel engine

To start the diesel engine when the engine is cold, it has to be pre-heated before starting the engine and then have to be warmed up before starting to drive.

Vehicle with manual transaxle:

1. Always carry the smart key with you.
2. Make sure the parking brake is applied.
3. Make sure the shift lever is in neutral.
4. Depress the clutch and brake pedal.
5. Press the Engine Start/Stop button.
6. Continue depressing the brake pedal until the glow indicator light (  ) goes out.
7. When the glow indicator light (  ) goes out, the engine will start.

Vehicle with automatic transaxle:

1. Always carry the smart key with you.
2. Make sure the parking brake is applied.
3. Make sure the shift lever is in P (Park).
4. Depress the brake pedal.
5. Press the Engine Start/Stop button.
6. Continue depressing the brake pedal until the glow indicator light (  ) goes out.
7. When the glow indicator light (  ) goes out, the engine will start.

### **NOTICE**

**If the Engine Start/Stop button is pressed while the engine is pre-heating, the engine may start.**

### Starting and stopping the engine for turbocharger intercooler

1. Do not race or accelerate the engine immediately after starting the engine.  
If the engine is cold, idle for several seconds before sufficient lubrication is ensured in the turbo charger unit.
2. After high speed or extended driving that requires heavy engine load, idle the engine about 1 minute before turning the engine off. This idle time will allow the turbocharger to cool prior to shutting the engine off.

#### **NOTICE**

**Do not turn off the engine immediately after it has been subjected to a heavy load. Doing so may cause severe damage to the engine or turbo charger unit.**

#### **NOTICE**

**To prevent damage to the vehicle:**

- **If the engine stalls while you are in motion, do not attempt to move the shift lever to the P (Park) position.**

**If traffic and road conditions permit, you may put the shift lever in the N (Neutral) position while the vehicle is still moving and press the Engine Start/Stop button in an attempt to restart the engine.**

- **Do not push or tow your vehicle to start the engine.**

#### **NOTICE**

**To prevent damage to the vehicle:**

**Do not press the Engine Start/Stop button for more than 10 seconds except when the stop lamp fuse is blown.**

**When the stop lamp fuse is blown, you can't start the engine normally. Replace the fuse with a new one. If you are not able to replace the fuse, you can start the engine by pressing and holding the Engine Start/Stop button for 10 seconds with the Engine Start/Stop button in the ACC position.**

**For your safety always depress the brake and/or clutch pedal before starting the engine.**



### **i** Information

**If the smart key battery is weak or the smart key does not work correctly, you can start the engine by pressing the Engine Start/Stop button with the smart key in the direction of the picture above.**

## MANUAL TRANSAXLE (IF EQUIPPED)

### ■ Type A

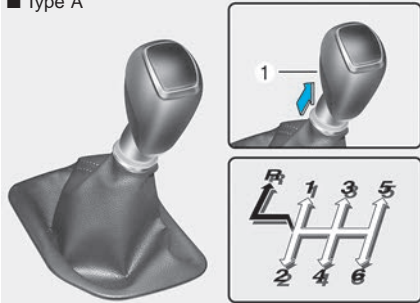

- ⇒ The shift lever can be moved without pressing the button (1).
- ➔ The button (1) must be pressed while moving the shift lever.

OTLE058005

### ■ Type B

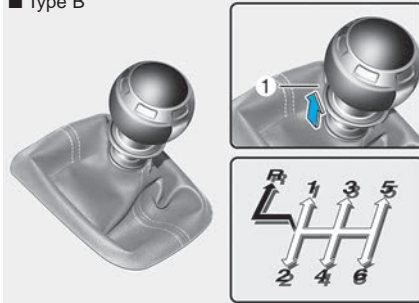

- ⇒ The shift lever can be moved without pulling up the ring (1).
- ➔ The ring (1) must be pulled up while moving the shift lever.

OPDEN057107

## Manual transaxle operation

The manual transaxle has 6 forward gears. The transaxle is fully synchronized in all forward gears so shifting to either a higher or a lower gear is easily accomplished.

### ⚠ WARNING

**Before leaving the driver's seat, always make sure the shift lever is in 1st gear when the vehicle is parked on a uphill and in R (Reverse) on a downhill, set the parking brake, and place the ignition switch in the LOCK/OFF position. Unexpected vehicle movement may occur if these precautions are not followed.**



To shift to R (Reverse), make sure the vehicle has completely stopped, and then move the shift lever to neutral before moving into R (Reverse).

When you've come to a complete stop and it's hard to shift into 1st gear or R (Reverse):

1. Put the shift lever in neutral and release the clutch pedal.
2. Depress the clutch pedal, and then shift into first or R (Reverse) gear.

### Information

**During cold weather, shifting may be difficult until the transaxle lubricant has warmed up.**

### **Using the clutch**

The clutch pedal should be depressed all the way to the floor before:

- Starting the engine  
The engine will not start without depressing the clutch pedal.
- Shifting

When releasing the clutch pedal, release it slowly. The clutch pedal should always be released while driving.

### **NOTICE**

**To prevent unnecessary wear or damage to the clutch:**

- Do not rest your foot on the clutch pedal while driving.
- Do not hold the vehicle with the clutch on an incline, while waiting for the traffic light, etc.
- Always depress the clutch pedal down fully to prevent noise or damage.
- Do not start with the 2nd (second) gear engaged except when you start on a slippery road.

### ***Downshifting***

Downshift when you must slow down in heavy traffic or drive up a steep hill to prevent engine load.

Also, downshifting reduces the chance of stalling and can accelerate when you need to increase your speed again.

When the vehicle is going downhill, downshifting helps maintain safe speed by providing brake power from the engine and enables less wear on the brakes.

### **NOTICE**

**To prevent damage to the engine, clutch and transaxle:**

- **When downshifting from 5th gear to 4th gear, be careful not to inadvertently push the shift lever sideways engaging the 2nd gear. A drastic downshift may cause the engine speed to increase to the point the tachometer will enter the red-zone.**
- **Do not downshift more than two gear at a time or downshift the gear when the engine is running at high speed (5,000 RPM or higher). Such a downshifting may damage the engine, clutch and the transaxle.**

### **Good driving practices**

- Never take the vehicle out of gear and coast down a hill. This is extremely dangerous.
- Don't "ride" the brakes. This can cause the brakes and related parts to overheat and malfunction.

When you are driving down a long hill, slow down and shift to a lower gear. Engine braking will help slow down the vehicle.

- Slow down before shifting to a lower gear. This will help avoid over-revving the engine, which can cause damage.
- Slow down when you encounter cross winds. This gives you much better control of your vehicle.
- Be sure the vehicle is completely stopped before you shift into R (Reverse) to prevent damage to the transaxle.

- Exercise extreme caution when driving on a slippery surface. Be especially careful when braking, accelerating or shifting gears. On a slippery surface, an abrupt change in vehicle speed can cause the drive wheels to lose traction and may cause loss of vehicle control resulting in an accident.

**⚠ WARNING**

Do not use the engine brake (shifting from a higher gear to lower gear) rapidly on slippery roads. The vehicle may slip causing an accident.

**⚠ WARNING**

To reduce the risk of **SERIOUS INJURY or DEATH:**

- **ALWAYS** wear your seatbelt. In a collision, an unbelted occupant is significantly more likely to be seriously injured or killed than a properly belted occupant.
- Avoid high speeds when cornering or turning.
- Do not make quick steering wheel movements, such as sharp lane changes or fast, sharp turns.
- The risk of rollover is greatly increased if you lose control of your vehicle at highway speeds.
- Loss of control often occurs if two or more wheels drop off the roadway and the driver over steers to reenter the roadway.

(Continued)

(Continued)

- In the event your vehicle leaves the roadway, do not steer sharply. Instead, slow down before pulling back into the travel lanes.
- **HYUNDAI** recommends you follow all posted speed limits.

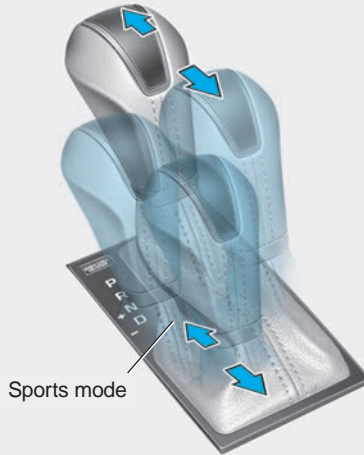
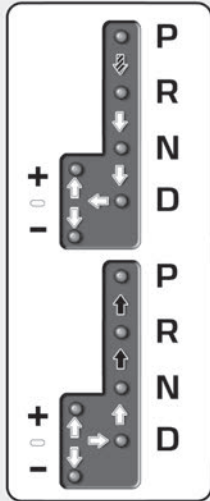

## AUTOMATIC TRANSAXLE (IF EQUIPPED)

■ Type A

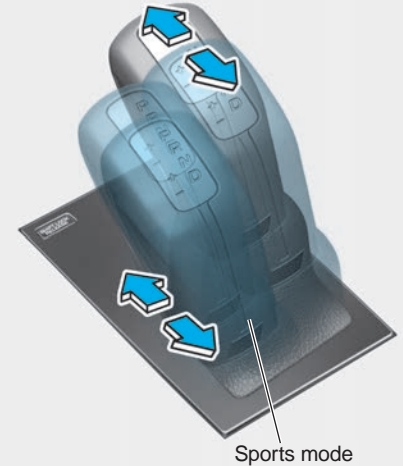
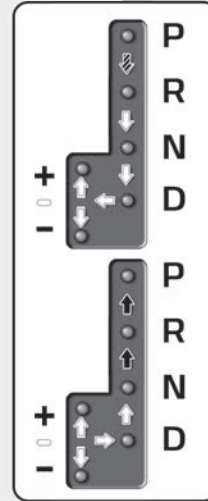

■ Type B



-  Depress the brake pedal and press the shift button while moving the shift lever.
-  Press the shift button while moving the shift lever.
-  The shift lever can freely operate.

OTL055006/OTLEN059006

### Automatic transaxle operation

The automatic transmission has six forward speeds (eight forward speeds, if equipped) and one reverse speed. The individual speeds are selected automatically in the D (Drive) position.

## WARNING

To reduce the risk of serious injury or death:

- **ALWAYS** check the surrounding areas near your vehicle for people, especially children, before shifting a vehicle into D (Drive) or R (Reverse).
- Before leaving the driver's seat, always make sure the shift lever is in the P (Park) position, then set the parking brake, and place the ignition switch in the LOCK/OFF position. Unexpected and sudden vehicle movement can occur if these precautions are not followed.
- Do not use the engine brake (shifting from a high gear to lower gear) rapidly on slippery roads. The vehicle may slip causing an accident.

### *Transaxle ranges*

The indicator in the instrument cluster displays the shift lever position when the ignition switch is in the ON position.

### **P (Park)**

Always come to a complete stop before shifting into P (Park).

To shift from P (Park), you must depress firmly on the brake pedal and make sure your foot is off the accelerator pedal.

**If you have done all of the above and still cannot shift the lever out of P (Park), see "Shift-Lock Release" in this chapter.**

The shift lever must be in P (Park) before turning the engine off.

## WARNING

- **Shifting into P (Park) while the vehicle is in motion may cause you to lose control of the vehicle.**
- **After the vehicle has stopped, always make sure the shift lever is in P (Park), apply the parking brake, and turn the engine off.**
- **Do not use the P (Park) position in place of the parking brake.**

### R (Reverse)

Use this position to drive the vehicle backward.

#### **NOTICE**

**Always come to a complete stop before shifting into or out of R (Reverse); you may damage the transaxle if you shift into R (Reverse) while the vehicle is in motion.**

### N (Neutral)

The wheels and transaxle are not engaged.

Use N (Neutral) if you need to restart a stalled engine, or if it is necessary to stop with the engine ON. Shift into P (Park) if you need to leave your vehicle for any reason.

Always depress the brake pedal when you are shifting from N (Neutral) to another gear.

#### **WARNING**

**Do not shift into gear unless your foot is firmly on the brake pedal. Shifting into gear when the engine is running at high speed can cause the vehicle to move very rapidly. You could lose control of the vehicle and hit people or objects.**

### D (Drive)

This is the normal driving position. The transaxle will automatically shift through a 6(or 8) - gear sequence, providing the best fuel economy and power.

For extra power when passing another vehicle or driving uphill, depress the accelerator fully. The transaxle will automatically downshift to the next lower gear (or gears, as appropriate).

The DRIVE MODE switch, located on the shift lever console, allows the driver to switch from NORMAL mode to SPORT mode. (if equipped)

**For more details, refer to "Drive Mode Integrated Control System" later in this chapter.**

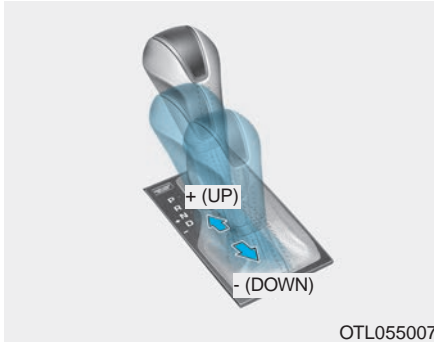

### Sports mode

Whether the vehicle is stationary or in motion, sports mode is selected by pushing the shift lever from the D (Drive) position into the manual gate. To return to D (Drive) range operation, push the shift lever back into the main gate.

In Sports Mode, moving the shift lever backwards and forwards will allow you to select the desired range of gears for the current driving conditions.

- + (Up) : Push the lever forward once to shift up one gear.
- (Down) : Pull the lever backwards once to shift down one gear.

### **i** Information

- **Only the six or eight forward gears can be selected. To reverse or park the vehicle, move the shift lever to the R (Reverse) or P (Park) position as required.**
- **Downshifts are made automatically when the vehicle slows down. When the vehicle stops, 1st gear is automatically selected.**
- **When the engine rpm approaches the red zone the transaxle will upshift automatically.**

(Continued)

(Continued)

- **If the driver presses the lever to + (Up) or - (Down) position, the transaxle may not make the requested gear change if the next gear is outside of the allowable engine rpm range. The driver must execute upshifts in accordance with road conditions, taking care to keep the engine rpms below the red zone.**
- **When driving on a slippery road, push the shift lever forward into the + (Up) position. This causes the transaxle to shift into the 2nd gear which is better for smooth driving on a slippery road. Push the shift lever to the - (Down) side to shift back to the 1st gear.**

### **Shift-lock system**

For your safety, the automatic transaxle has a shift-lock system which prevents shifting the transaxle from P (Park) into R (Reverse) unless the brake pedal is depressed. To shift the transaxle from P (Park) into R (Reverse):

1. Depress and hold the brake pedal.
2. Start the engine or place the ignition switch in the ON position.
3. Move the shift lever.

### **Shift-lock release**

If the shift lever cannot be moved from the P (Park) position into R (Reverse) position with the brake pedal depressed, continue depressing the brake, and then do the following:

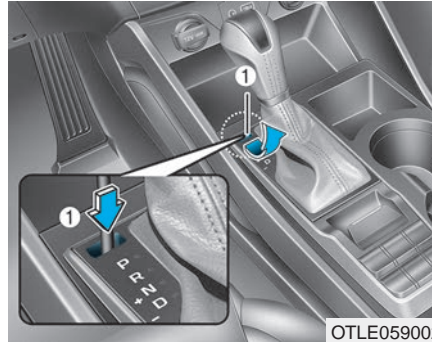

1. Place the ignition switch in the LOCK/OFF position.
2. Apply the parking brake.
3. Carefully remove the cap (1) covering the shift-lock access hole.
4. Insert a tool (e.g. flathead screwdriver) into the access hole and press down on the tool.
5. Move the shift lever while holding down the screwdriver.
6. Remove the tool from the shiftlock release access hole then install the cap.
7. Depress the brake pedal, and then restart the engine.

If you need to use the shift-lock release, we recommend that the system be inspected by an authorized HYUNDAI dealer immediately.



### **Ignition key interlock system (if equipped)**

The ignition key cannot be removed unless the shift lever is in the P (Park) position.

### **Parking**

Always come to a complete stop and continue to depress the brake pedal. Move the shift lever into the P (Park) position, apply the parking brake, and place the ignition switch in the LOCK/OFF position. Take the Key with you when exiting the vehicle.

#### **⚠ WARNING**

**When you stay in the vehicle with the engine running, be careful not to depress the accelerator pedal for a long period of time. The engine or exhaust system may overheat and start a fire.**

**The exhaust gas and the exhaust system are very hot. Keep away from the exhaust system components.**

**Do not stop or park over flammable materials, such as dry grass, paper or leaves. They may ignite and cause a fire.**

### **Good driving practices**

- Never move the shift lever from P (Park) or N (Neutral) to any other position with the accelerator pedal depressed.
- Never move the shift lever into P (Park) when the vehicle is in motion.

Be sure the vehicle is completely stopped before you attempt to shift into R (Reverse) or D (Drive).

- Do not move the shift lever to N (Neutral) when driving. Doing so may result in an accident because of a loss of engine braking and the transaxle could be damaged.
- Do not drive with your foot resting on the brake pedal. Even light, but consistent pedal pressure can result in the brakes overheating, brake wear and possibly even brake failure.
- When driving in sports mode, slow down before shifting to a lower gear. Otherwise, the lower gear may not be engaged if the engine rpms are outside of the allowable range.

- Always apply the parking brake when leaving the vehicle. Do not depend on placing the transaxle in P (Park) to keep the vehicle from moving.
- Exercise extreme caution when driving on a slippery surface. Be especially careful when braking, accelerating or shifting gears. On a slippery surface, an abrupt change in vehicle speed can cause the drive wheels to lose traction and may cause loss of vehicle control resulting in an accident.
- Optimum vehicle performance and economy is obtained by smoothly depressing and releasing the accelerator.

### **WARNING**

#### **To reduce the risk of SERIOUS INJURY or DEATH:**

- **ALWAYS wear your seatbelt. In a collision, an unbelted occupant is significantly more likely to be seriously injured or killed than a properly belted occupant.**
- **Avoid high speeds when cornering or turning.**
- **Do not make quick steering wheel movements, such as sharp lane changes or fast, sharp turns.**
- **The risk of rollover is greatly increased if you lose control of your vehicle at highway speeds.**
- **Loss of control often occurs if two or more wheels drop off the roadway and the driver over steers to reenter the roadway.**

**(Continued)**

#### **(Continued)**

- **In the event your vehicle leaves the roadway, do not steer sharply. Instead, slow down before pulling back into the travel lanes.**
- **HYUNDAI recommends you follow all posted speed limits.**

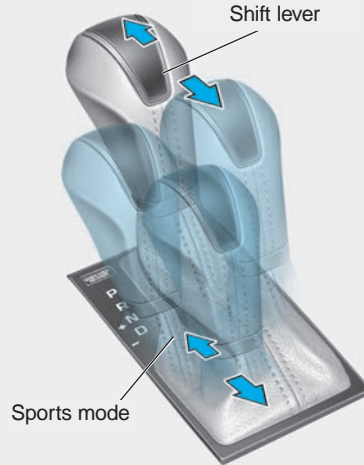
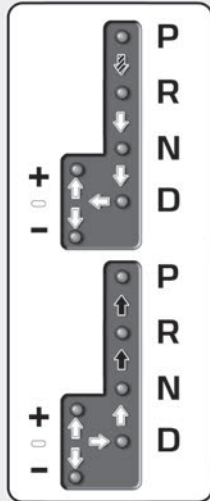

## DUAL CLUTCH TRANSMISSION (IF EQUIPPED)

■ Type A

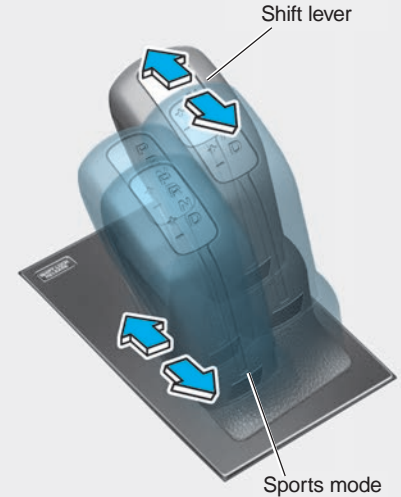
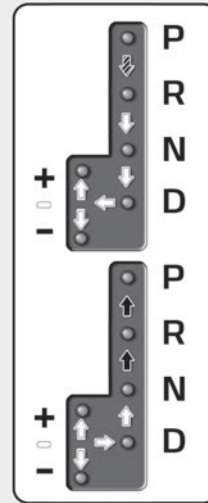

■ Type B



-  Depress the brake pedal and press the shift button while moving the shift lever.
-  Press the shift button while moving the shift lever.
-  The shift lever can freely operate.

OTL055006/OTLEN059006

### Dual clutch transmission operation

The dual clutch transmission has seven forward speeds and one reverse speed. The individual speeds are selected automatically in the D (Drive) position.

**⚠ WARNING**

To reduce the risk of serious injury or death:

- **ALWAYS** check the surrounding areas near your vehicle for people, especially children, before shifting a vehicle into D (Drive) or R (Reverse).
- Before leaving the driver's seat, always make sure the shift lever is in the P (Park) position, then set the parking brake, and place the ignition switch in the LOCK/OFF position. Unexpected and sudden vehicle movement can occur if these precautions are not followed.
- Do not use the engine brake (shifting from a high gear to lower gear) rapidly on slippery roads. The vehicle may slip causing an accident.

(Continued)

(Continued)

- **To avoid damage to your transaxle, do not try to accelerate in R (Reverse) or any forward gear position with the brakes on.**
  - **When stopped on slope, do not hold the vehicle with accelerator pedal. Use the service brake or the parking brake.**
- The dual clutch transmission gives the driving feel of a manual transaxle, yet provides the ease of a fully automatic transaxle. Unlike a traditional automatic transaxle, the gear shifting can be felt (and heard) on the dual clutch transmission
    - Think of it as an automatically shifting manual transaxle.
    - Shift into Drive range and get fully automatic shifting, similar to a conventional automatic transaxle.

- Dual clutch transmission adopts dry-type dual clutch, which is different from torque converter of automatic transaxle, and shows better acceleration performance during driving. But, initial launch might be little bit slower than Automatic Transaxle.
- Gear shifts are sometimes more noticeable than a conventional automatic transmission and a light vibration during launching can be felt as the transmission speed is matched with the engine speed. This is a normal condition of the dual clutch transmission.
- The dry-type clutch transfers torque and provides a direct driving feeling which may feel different from a conventional automatic transaxle with a torque converter. This may be more noticeable when starting from a stop or low vehicle speed.
- When rapidly accelerating at low vehicle speed, engine could rev at high rpm depending on vehicle drive condition.

- For smooth launch uphill, press down the accelerator pedal smoothly depending on the current conditions.
- If you release your foot from the accelerator pedal at low vehicle speed, you may feel strong engine brake, which is similar to manual transaxle.
- When driving downhill, you may use Sports Mode to downshift to a lower gear in order to control your speed without using the brake pedal excessively.
- When you turn the engine on and off, you may hear clicking sounds as the system goes through a self test. This is a normal sound for the Dual clutch transmission.

### **⚠ WARNING**

**Due to transmission failure, you may not continue to drive and the position indicator (D, R) on the cluster will blink. We recommend you to contact an authorized HYUNDAI dealer and have the system checked.**

## **LCD display for transmission temperature and warning message**

### **Transmission temperature gauge**

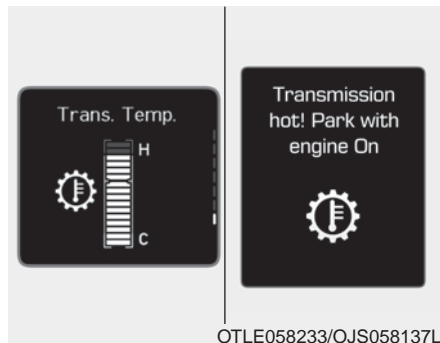

- Select trip computer mode on the LCD display and move to the transmission temperature screen to see the temperature of the dual clutch transmission.
- Try to drive so that the temperature gauge do not show high/overheat. When the transmission is overheated, the warning message will display on the LCD. Follow the displayed message.

- The transmission temperature is displayed in three colors (white, orange and red) as it increases. (if equipped with the cluster type B)
- Orange temperature gauge is displayed right before the warning message appears on the LCD display. (if equipped)

### **⚠ CAUTION**

- **Increase (high temperature) of the transmission temperature gauge usually appears on an incline when the vehicle is stopped for a long time using accelerator pedal, without depressing the brake pedal.**
- **To maintain the optimal transmission performance, drive so that the white gauge is not exceeded. (if equipped)**

**Normal (below marking 10)**

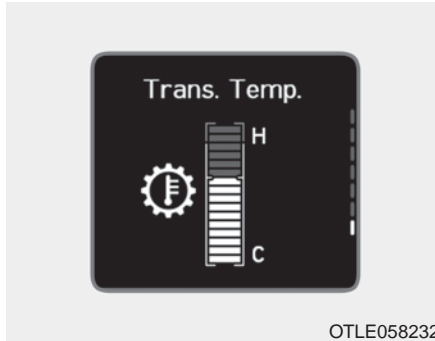

- In order to maintain the optimal gear shift performance, drive so that the temperature gauge is below the point (below marking 10).
- Gauge color according to cluster type
  - Type A : White
  - Type B : White

**i Information**

The temperature gauge may increase rapidly if clutch slip occurs excessively due to repeated stop-and-go driving on steep grades and when Hill Hold is maintained for a long time. In order to prevent excessive temperature increase, use the brake during low speed driving or when stopping the vehicle on a hill.

**Before entering High/Overheat (from marking 10 to 14)**

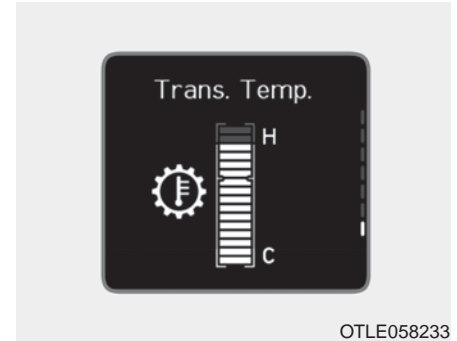

- This zone shows that the dual clutch temperature of the DCT is before entering the high/overheat zone. When the clutch temperature is within this zone (from marking 10 to 14), drive minimizing the clutch slip so that the temperature gauge is below the point (marking 10).

- If the dual clutch temperature continues to increase and reaches marking 14, the warning alarm sounds and the temperature gauge pops up on the cluster.

The DCT warning message is not displayed.

- Gauge color according to cluster type
  - Type A : White
  - Type B : Orange

### **High/Overheat (from marking 15 to 16)**

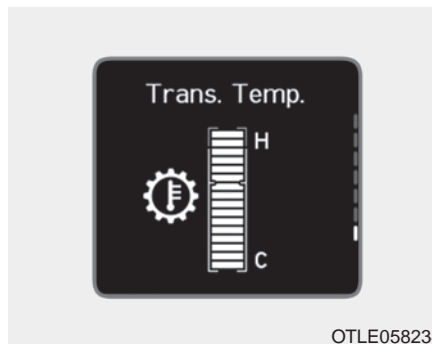

- This zone shows that the dual clutch temperature of the DCT has entered the high/overheat zone.

The DCT warning alarm sounds, warning message is displayed on the cluster and the temperature gauge disappears from the cluster. Follow the displayed warning message.

- To check the temperature status of the dual clutch when overheated, move to the temperature gauge screen by selecting the trip computer mode. Then, you can check the temperature status of the dual clutch.

- Gauge color according to cluster type
  - Type A : White
  - Type B : Red

### DCT warning messages



This warning message is displayed when vehicle is driven slowly on a grade and the vehicle detects that the brake pedal is not applied.

#### Steep grade

Driving up hills or on steep grades:

- To hold the vehicle on an incline use the foot brake or the parking brake.
- When in stop-and-go traffic on an incline, keep some distance ahead before moving the vehicle forward. Then hold the vehicle on the incline with the foot brake.

- If the vehicle is held on a hill by applying the accelerator pedal or by creeping with brake pedal disengaged, the clutch and transmission may overheat which can result in damage. At this time, a warning message will appear on the LCD display.
- If the LCD warning is active, the foot brake must be applied.
- Ignoring the warnings can lead to damage to the transmission.

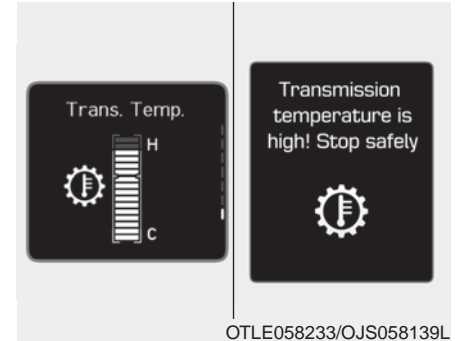

#### Transmission high temperature

- Under certain conditions, such as repeated stop-and-go launches on steep grades, sudden take off or acceleration, or other harsh driving conditions, the transmission clutch temperatures will increase excessively. Finally the clutch in transmission could be overheated.
- When the clutch is overheated, the safe protection mode engages and the gear position indicator on the cluster blinks with a chime. At this time, "Transmission temperature is high! Stop safely" warning message will appear on the LCD display and driving may not be smooth.



- If this occurs, pull over to a safe location, stop the vehicle with the engine running, apply the brakes and shift the vehicle to P (Park), and allow the transmission to cool.
- If you ignore this warning, the driving condition may become worse. You may experience abrupt shifts, frequent shifts, or jerkiness. To return to the normal driving condition, stop the vehicle and apply the foot brake or shift into P (Park). Then allow the transmission to cool for a few minutes with engine on, before driving off.
- When possible, drive the vehicle smoothly.

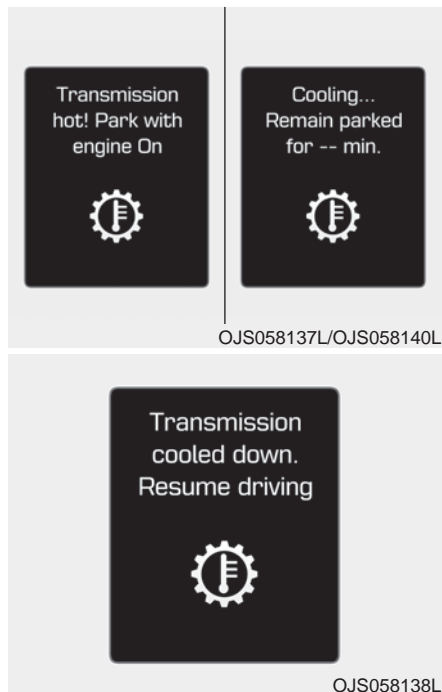

**Transmission overheated**

- If the vehicle continues to be driven and the clutch temperatures reach the maximum temperature limit, the "Transmission hot! Park with engine On" warning will be displayed. When this occurs the clutch is disabled until the clutch cools to normal temperatures.
- The warning will display a time to wait for the transmission to cool.
- If this occurs, pull over to a safe location, stop the vehicle with the engine running, apply the brakes and shift the vehicle to P (Park), and allow the transmission to cool.
- When the message "Transmission cooled down. Resume driving" appears you can continue to drive your vehicle.
- When possible, drive the vehicle smoothly.

If any of the warning messages in the LCD display continue to blink, for your safety, we recommend you contact an authorized HYUNDAI dealer and have the system checked.

### Transmission ranges

The indicator in the instrument cluster displays the shift lever position when the ignition switch is in the ON position.

#### P (Park)

Always come to a complete stop before shifting into P (Park).

To shift from P (Park), you must depress firmly on the brake pedal and make sure your foot is off the accelerator pedal.

**If you have done all of the above and still cannot shift the lever out of P (Park), see "Shift-Lock Release" in this chapter.**

The shift lever must be in P (Park) before turning the engine off.

### WARNING

- **Shifting into P (Park) while the vehicle is in motion may cause you to lose control of the vehicle.**
- **After the vehicle has stopped, always make sure the shift lever is in P (Park), apply the parking brake, and turn the engine off.**
- **Do not use the P (Park) position in place of the parking brake.**

#### R (Reverse)

Use this position to drive the vehicle backward.

### NOTICE

**Always come to a complete stop before shifting into or out of R (Reverse); you may damage the transaxle if you shift into R (Reverse) while the vehicle is in motion.**

#### N (Neutral)

The wheels and transaxle are not engaged.

Use N (Neutral) if you need to restart a stalled engine, or if it is necessary to stop with the engine ON. Shift into P (Park) if you need to leave your vehicle for any reason.

Always depress the brake pedal when you are shifting from N (Neutral) to another gear.

## D (Drive)

This is the normal driving position. The transmission will automatically shift through a 7-gear sequence, providing the best fuel economy and power.

For extra power when passing another vehicle or driving uphill, depress the accelerator fully. The transmission will automatically downshift to the next lower gear (or gears, as appropriate).

The DRIVE MODE switch, located on the shift lever console, allows the driver to switch from NORMAL mode to SPORT mode. (if equipped)

**For more details, refer to "Drive Mode Integrated Control System" later in this chapter.**

### WARNING

- **Do not shift into gear unless your foot is firmly on the brake pedal. Shifting into gear when the engine is running at high speed can cause the vehicle to move very rapidly. You may lose control of the vehicle and cause accidents.**
- **Do not drive with the shift lever in N (Neutral). The engine brake will not work and may lead to an accident.**

### NOTICE

**Always make sure the vehicle is stationary, at a complete stop, before selecting D (Drive).**

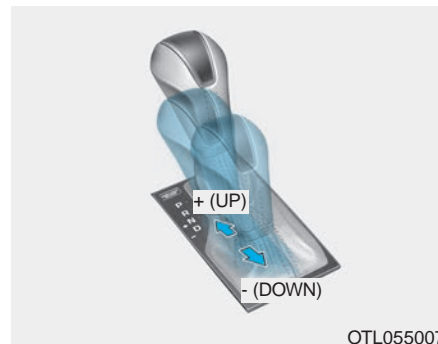

### Sports mode

Whether the vehicle is stationary or in motion, sports mode is selected by pushing the shift lever from the D (Drive) position into the manual gate. To return to D (Drive) range operation, push the shift lever back into the main gate.

In manual shift mode, moving the shift lever backwards and forwards will allow you to select the desired range of gears for the current driving conditions.

Up (+) : Push the lever forward once to shift up one gear.

Down (-) : Pull the lever backwards once to shift down one gear.

**i** Information

- Only the seven forward gears can be selected. To reverse or park the vehicle, move the shift lever to the R (Reverse) or P (Park) position as required.
- Downshifts are made automatically when the vehicle slows down. When the vehicle stops, 1st gear is automatically selected.
- When the engine rpm approaches the red zone the transmission will upshift automatically.
- If the driver presses the lever to + (Up) or - (Down) position, the transmission may not make the requested gear change if the next gear is outside of the allowable engine rpm range. The driver must execute upshifts in accordance with road conditions, taking care to keep the engine rpms below the red zone.

**Shift-lock system**

For your safety, the dual clutch transmission has a shift-lock system which prevents shifting the transmission from P (Park) into R (Reverse) unless the brake pedal is depressed.

To shift the transmission from P (Park) into R (Reverse):

1. Depress and hold the brake pedal.
2. Start the engine or place the ignition switch in the ON position.
3. Move the shift lever.

**Shift-lock release**

If the shift lever cannot be moved from the P (Park) position into R (Reverse) position with the brake pedal depressed, continue depressing the brake, and then do the following:

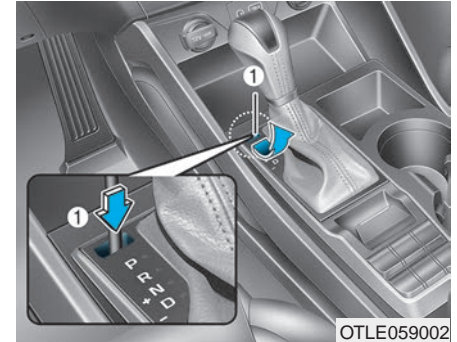

1. Place the ignition switch in the LOCK/OFF position.
2. Apply the parking brake.
3. Carefully remove the cap (1) covering the shift-lock access hole.
4. Insert a tool (e.g. flathead screwdriver) into the access hole and press down on the tool.
5. Move the shift lever while holding down the screwdriver.
6. Remove the tool from the shiftlock release access hole then install the cap.
7. Depress the brake pedal, and then restart the engine.

If you need to use the shift-lock release, we recommend that the system be inspected by an authorized HYUNDAI dealer immediately.

### ***Ignition key interlock system (if equipped)***

The ignition key cannot be removed unless the shift lever is in the P (Park) position.

### **Parking**

Always come to a complete stop and continue to depress the brake pedal. Move the shift lever into the P (Park) position, apply the parking brake, and place the ignition switch in the LOCK/OFF position. Take the Key with you when exiting the vehicle.

#### **⚠ WARNING**

**When you stay in the vehicle with the engine running, be careful not to depress the accelerator pedal for a long period of time. The engine or exhaust system may overheat and start a fire.**

**The exhaust gas and the exhaust system are very hot. Keep away from the exhaust system components.**

**Do not stop or park over flammable materials, such as dry grass, paper or leaves. They may ignite and cause a fire.**

### **Good driving practices**

- Never move the shift lever from P (Park) or N (Neutral) to any other position with the accelerator pedal depressed.
- Never move the shift lever into P (Park) when the vehicle is in motion.

Be sure the vehicle is completely stopped before you attempt to shift into R (Reverse) or D (Drive).

- Do not move the shift lever to N (Neutral) when driving. Doing so may result in an accident because of a loss of engine braking and the transmission could be damaged.
- Do not drive with your foot resting on the brake pedal. Even light, but consistent pedal pressure can result in the brakes overheating, brake wear and possibly even brake failure.
- When driving in sports mode, slow down before shifting to a lower gear. Otherwise, the lower gear may not be engaged if the engine rpms are outside of the allowable range.

- Always apply the parking brake when leaving the vehicle. Do not depend on placing the transmission in P (Park) to keep the vehicle from moving.
- Exercise extreme caution when driving on a slippery surface. Be especially careful when braking, accelerating or shifting gears. On a slippery surface, an abrupt change in vehicle speed can cause the drive wheels to lose traction and may cause loss of vehicle control resulting in an accident
- Optimum vehicle performance and economy is obtained by smoothly depressing and releasing the accelerator.

### WARNING

To reduce the risk of **SERIOUS INJURY or DEATH:**

- **ALWAYS** wear your seatbelt. In a collision, an unbelted occupant is significantly more likely to be seriously injured or killed than a properly belted occupant.

(Continued)

### (Continued)

- **Avoid high speeds when cornering or turning.**
- **Do not make quick steering wheel movements, such as sharp lane changes or fast, sharp turns.**
- **The risk of rollover is greatly increased if you lose control of your vehicle at highway speeds.**
- **Loss of control often occurs if two or more wheels drop off the roadway and the driver over steers to reenter the roadway.**
- **In the event your vehicle leaves the roadway, do not steer sharply. Instead, slow down before pulling back into the travel lanes.**
- **HYUNDAI recommends you follow all posted speed limits.**

### WARNING

If your vehicle is stuck in snow, mud, sand, etc., you may attempt to free the vehicle by rocking it back and forth. Do not attempt this procedure if people or objects are anywhere near. Vehicle may suddenly move forward or backward as it becomes unstuck, causing injury or damage to nearby people or objects.

### Information - Kickdown Mechanism (if equipped)

Use the kickdown mechanism for maximum acceleration. Depress the accelerator pedal beyond the pressure point. The automatic transaxle will shift to a lower gear depending on the engine speed.

## BRAKING SYSTEM

### Power brakes

Your vehicle has power-assisted brakes that adjust automatically through normal usage.

If the engine is not running or is turned off while driving, the power assist for the brakes will not work. You can still stop your vehicle by applying greater force to the brake pedal than typical. The stopping distance, however, will be longer than with power brakes.

When the engine is not running, the reserve brake power is partially depleted each time the brake pedal is applied. Do not pump the brake pedal when the power assist has been interrupted.

Pump the brake pedal only when necessary to maintain steering control on slippery surfaces.

### WARNING

Take the following precautions:

- **Do not drive with your foot resting on the brake pedal. This will create abnormal high brake temperatures, excessive brake lining and pad wear, and increased stopping distances.**
- **When descending a long or steep hill, shift to a lower gear and avoid continuous application of the brakes. Applying the brakes continuously will cause the brakes to overheat and could result in a temporary loss of braking performance.**

(Continued)

(Continued)

- **Wet brakes may impair the vehicle's ability to safely slow down; the vehicle may also pull to one side when the brakes are applied. Applying the brakes lightly will indicate whether they have been affected in this way. Always test your brakes in this fashion after driving through deep water. To dry the brakes, lightly tap the brake pedal to heat up the brakes while maintaining a safe forward speed until brake performance returns to normal. Avoid driving at high speeds until the brakes function correctly.**

### Disc brakes wear indicator

When your brake pads are worn and new pads are required, you will hear a high pitched warning sound from your front or rear brakes. You may hear this sound come and go or it may occur whenever you depress the brake pedal.

Please remember some driving conditions or climates may cause a brake squeal when you first apply (or lightly apply) the brakes. This is normal and does not indicate a problem with your brakes.

#### **NOTICE**

**To avoid costly brake repairs, do not continue to drive with worn brake pads.**

#### **i Information**

**Always replace brake pads as complete front or rear axle sets.**

### Parking brake (hand type, if equipped)

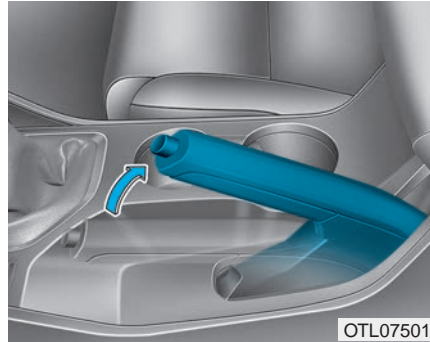

Always set the parking brake before leaving the vehicle, to apply:

Firmly depress the brake pedal.

Pull up the parking brake lever as far as possible.

#### **⚠ WARNING**

**To reduce the risk of SERIOUS INJURY or DEATH, do not operate the parking brake while the vehicle is moving except in an emergency situation. It could damage the brake system and lead to an accident.**



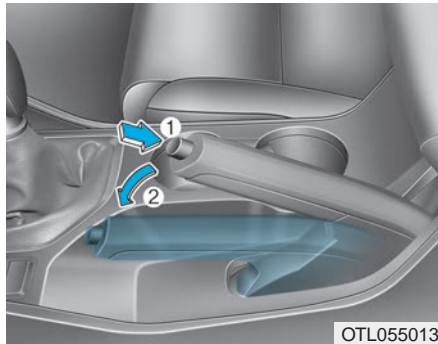

To release:

Firmly depress the brake pedal.

Slightly pull up the parking brake lever.

While pressing the release button (1), lower the parking brake (2).

If the parking brake does not release or does not release all the way, we recommend that the system be checked by an authorized HYUNDAI dealer.

## WARNING

- Whenever leaving the vehicle or parking, always come to a complete stop and continue to depress the brake pedal. Move the shift lever into the 1st gear (for manual transaxle vehicle) or P (Park, for automatic transaxle/dual clutch transmission vehicle) position, then apply the parking brake, and place the ignition switch in the LOCK/OFF position.

Vehicles with the parking brake not fully engaged are at risk for moving inadvertently and causing injury to yourself or others.

- **NEVER** allow anyone who is unfamiliar with the vehicle to touch the parking brake. If the parking brake is released unintentionally, serious injury may occur.
- Only release the parking brake when you are seated inside the vehicle with your foot firmly on the brake pedal.

## NOTICE

- Do not apply the accelerator pedal while the parking brake is engaged. If you depress the accelerator pedal with the parking brake engaged, warning will sound. Damage to the parking brake may occur.
- Driving with the parking brake on can overheat the braking system and cause premature wear or damage to brake parts. Make sure the parking brake is released and the Brake Warning Light is off before driving.



Check the Parking Brake Warning Light by placing the ignition switch to the ON position (do not start the engine).

This light will be illuminated when the parking brake is applied with the ignition switch in the START or ON position.

Before driving, be sure the parking brake is released and the Brake Warning Light is OFF.

If the Parking Brake Warning Light remains on after the parking brake is released while engine is running, there may be a malfunction in the brake system. Immediate attention is necessary.

If at all possible, cease driving the vehicle immediately. If that is not possible, use extreme caution while operating the vehicle and only continue to drive the vehicle until you can reach a safe location.

## Electronic Parking Brake (EPB) (if equipped)

### Applying the parking brake

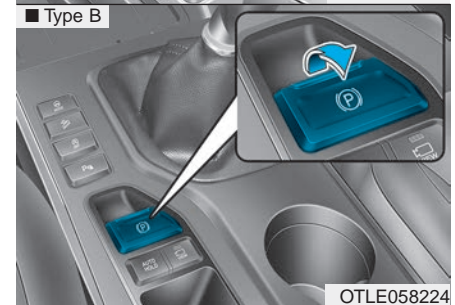
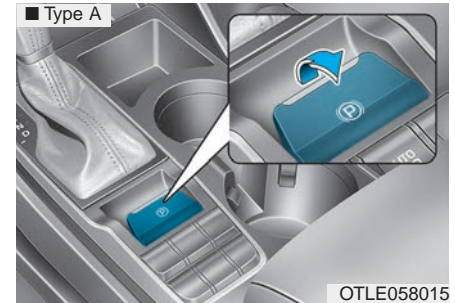

## To apply the EPB (Electronic Parking Brake):

1. Depress the brake pedal.
2. Pull up the EPB switch.

Make sure the Parking Brake Warning Light comes on.

Also, the EPB is applied automatically if the [AUTO HOLD] switch is on when the engine is turned off. However, if you press the EPB switch within one second after the engine is turned off, the EPB will not be applied.

### WARNING

To reduce the risk of **SERIOUS INJURY** or **DEATH**, do not operate the EPB while the vehicle is moving except in an emergency situation. It could damage the brake system and lead to an accident.

## Releasing the parking brake

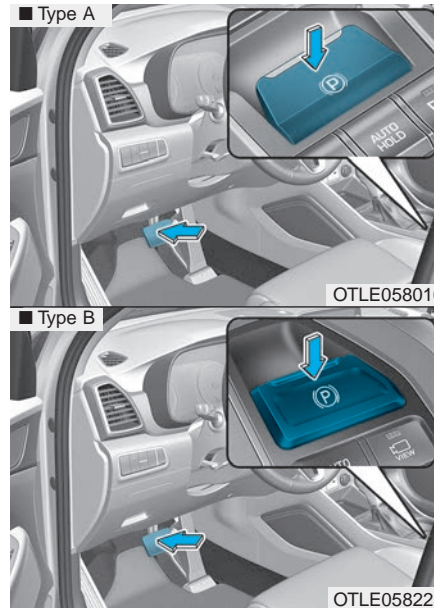

To release the EPB (Electronic Parking Brake), press the EPB switch in the following condition:

- Place the Engine Start/Stop button in the ON position.

- Depress the brake pedal. Make sure the Parking Brake Warning Light goes off.

## To release EPB (Electronic Parking Brake) automatically:

- Shift lever in P (Park)  
With the engine running depress the brake pedal and shift out of P (Park) to R (Rear) or D (Drive).
- Shift lever in N (Neutral)  
With the engine running depress the brake pedal and shift out of N (Neutral) to R (Rear) or D (Drive).
- Manual transmission vehicle
  1. Ensure seat belts are fastened and the doors, hood and tailgate are closed.
  2. With the engine running, depress the clutch pedal and move the shift lever to 1 (First) gear or R (Reverse).
  3. Depress the accelerator pedal while releasing the clutch pedal.

- Automatic transaxle/Dual clutch transmission vehicle
  1. Start the engine.
  2. Fasten the driver's seat belt.
  3. Close the driver's door, engine hood and tailgate.
  4. Depress the accelerator pedal while the shift lever is in R (Rear), D (Drive) or Sports mode.

Make sure the Parking Brake Warning light goes off.

### **i** Information

- For your safety, you can engage the EPB even though the Engine Stop/Start button is in the OFF position, but you cannot release it.
- For your safety, depress the brake pedal and release the parking brake manually with the EPB switch when you drive downhill or when backing up the vehicle.

### **i** Information - Manual transmission

A vehicle towing a trailer on a hill or on an incline may slightly roll backwards when starting the vehicle. To prevent the situation follow the below instructions.

1. Depress the clutch pedal and select a gear.
2. Keep pulling up the EPB switch.
3. Depress the accelerator pedal and slowly release the clutch pedal.
4. If the vehicle starts off with enough driving power release the EPB switch.

Do not follow the above procedure when driving on a flat level ground. The vehicle may suddenly move forward.

### **NOTICE**

- If the parking brake warning light is still on even though the EPB has been released, we recommend that the system be checked by an authorized HYUNDAI dealer.
- Do not drive your vehicle with the EPB applied. It may cause excessive brake pad and brake rotor wear.

### When the EPB (Electronic Parking Brake) does not release:

We recommend that you contact an authorized HYUNDAI dealer by loading the vehicle on a flatbed tow truck and have the system checked.

### EPB (Electronic Parking Brake) may be automatically applied when:

- The EPB is overheated
- It is requested by other systems
- The engine is turned off with the EPB applied

### **i** Information

If the driver turns the engine off while Auto Hold is operating, EPB will be automatically applied. However, if you press the EPB switch within one second after the engine is turned off, the EPB will not be applied.

### Warning messages

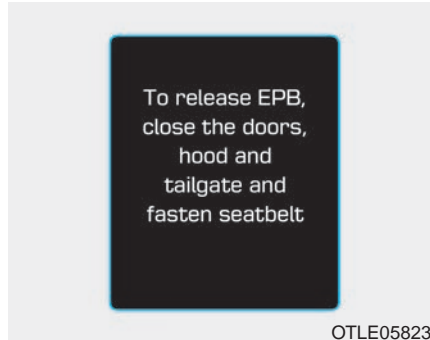

### To release EPB, close door, hood and tailgate and fasten seatbelt

- When you try to drive with the EPB applied, a warning will sound and a message will appear.
- If the driver's seat belt is unfastened and the engine hood or tailgate is opened, a warning will sound and a message will appear.
- When there is a problem with the vehicle, a warning may sound and a message may appear.

If the situation occurs, depress the brake pedal and release EPB by pressing the EPB switch.

### **!** WARNING

- Whenever leaving the vehicle or parking, always come to a complete stop and continue to depress the brake pedal.

Move the shift lever into the P (Park) position, press the EPB switch, and press the Engine Start/Stop button to the OFF position. Take the Smart Key with you when exiting the vehicle.

Vehicles not fully engaged in P (Park) with the parking brake set are at risk for moving inadvertently and causing injury to yourself or others.

- NEVER allow anyone who is unfamiliar with the vehicle to touch the EPB switch. If the EPB is released unintentionally, serious injury may occur.
- Only release the EPB when you are seated inside the vehicle with your foot firmly on the brake pedal.

### NOTICE

- Do not apply the accelerator pedal while the parking brake is engaged. If you depress the accelerator pedal with the EPB engaged, a warning will sound and a message will appear. Damage to the parking brake may occur.
- Driving with the parking brake on can overheat the braking system and cause premature wear or damage to brake parts. Make sure the EPB is released and the Parking Brake Warning Light is off before driving.

### **i** Information

- A clicking sound may be heard while operating or releasing the EPB. These conditions are normal and indicate that the EPB is functioning properly.
- When leaving your keys with a parking attendant or assistant, make sure to inform him/her how to operate the EPB.

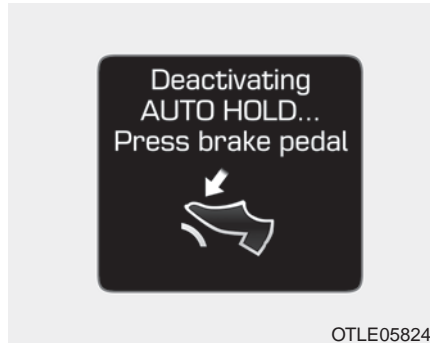

OTLE058241

#### **Deactivating AUTO HOLD.. Press brake pedal**

When the conversion from Auto Hold to EPB is not working properly a warning will sound and a message will appear.



OTLE058242

#### **Parking brake automatically applied**

If the EPB is applied while Auto Hold is activated, a warning will sound and a message will appear.

## EPB malfunction indicator (if equipped)



If the EPB malfunction indicator remains on, comes on while driving, or does not come on when the Engine Start/Stop button is changed to the ON position, this indicates that the EPB may have malfunctioned.

If this occurs, we recommend that the system be checked by an authorized HYUNDAI dealer.

The EPB malfunction indicator may illuminate when the ESC indicator comes on to indicate that the ESC is not working properly, but it does not indicate a malfunction of the EPB.

### NOTICE

- If the EPB warning light is still on, we recommend that the system be checked by an authorized HYUNDAI dealer.
- If the parking brake warning light does not illuminate or blinks even though the EPB switch was pulled up, the EPB may not be applied.
- If the parking brake warning light blinks when the EPB warning light is on, press the switch, and then pull it up. Repeat this one more time. If the EPB warning does not go off, we recommend that the system be checked by an authorized HYUNDAI dealer.

## Emergency braking

If there is a problem with the brake pedal while driving, emergency braking is possible by pulling up and holding the EPB switch. Braking is possible only while you are holding the EPB switch.

### ⚠ WARNING

Do not operate the parking brake while the vehicle is moving except in an emergency situation. It could damage the brake system and lead to a severe accident.

### **i** Information

During emergency braking, the parking brake warning light will illuminate to indicate that the system is operating.

### NOTICE

If you continuously notice a noise or burning smell when the EPB is used for emergency braking, we recommend that the system be checked by an authorized HYUNDAI dealer.

### When the EPB (Electronic Parking Brake) does not release

If the EPB does not release normally, we recommend that you contact an authorized HYUNDAI dealer by loading the vehicle on a flatbed tow truck and have the system checked.

### AUTO HOLD (if equipped)

This feature keeps the brake applied when the shift lever is in D (Drive), R (Reverse), N (Neutral) or Sports Mode with the feature enabled and when the brake pedal has been depressed to stop the vehicle.

### To apply :

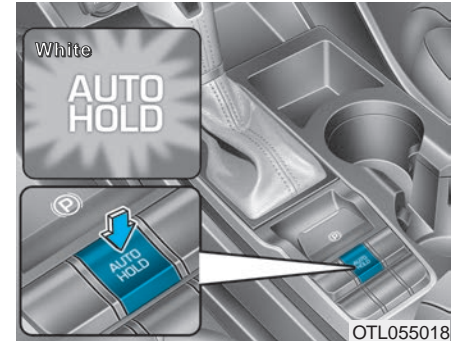

1. With the driver's door, engine hood and tailgate closed, fasten the driver's seat belt or depress the brake pedal and then press the [AUTO HOLD] switch. The white [AUTO HOLD] indicator will come on and the system will be in the standby position.



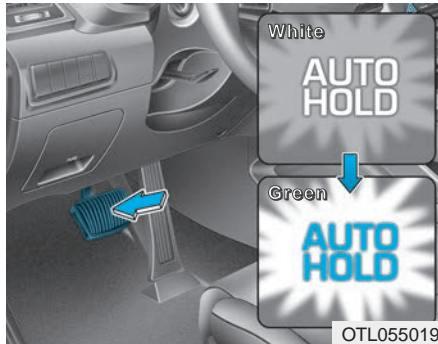

2. When you stop the vehicle completely by depressing the brake pedal, the AUTO HOLD indicator changes from white to green.
3. The vehicle will remain stationary even if you release the brake pedal.
4. If EPB is applied, Auto Hold will be released.

#### To release :

If you press the accelerator pedal with the shift lever in R (Reverse), D (Drive) or sports mode, the Auto Hold will be released automatically and the vehicle will start to move. The indicator changes from green to white.

#### WARNING

**When the AUTO HOLD is automatically released by depressing the accelerator pedal, always take a look around your vehicle. Slowly depress the accelerator pedal for a smooth start.**

#### To cancel :

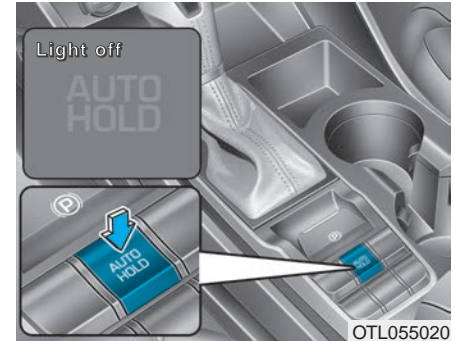

1. Depress the brake pedal.
2. Press the [AUTO HOLD] switch. The AUTO HOLD indicator will turn off.

**⚠ WARNING**

To prevent, unexpected and sudden vehicle movement, **ALWAYS** press your foot on the brake pedal to cancel the Auto Hold before you:

- Drive downhill.
- Drive the vehicle in R (Reverse).
- Park the vehicle.

**i Information**

- The Auto Hold does not operate when:
  - The driver's seat belt is unfastened and driver's door is opened
  - The engine hood is opened
  - The tailgate is opened
  - The shift lever is in P (Park)
  - The EPB is applied
- For your safety, the Auto Hold automatically switches to EPB when:
  - The driver's seat belt is unfastened and driver's door is opened
  - The engine hood is opened with the shift lever is in D (Drive)
  - The tailgate is opened with the shift lever is in R (Reverse)
  - The vehicle stops for more than 10 minutes
  - The vehicle stands on a steep slope
  - The vehicle moves several times

(Continued)

(Continued)

In these cases, the brake warning light comes on, the AUTO HOLD indicator changes from green to white, and a warning sound and a message will appear to inform you that EPB has been automatically engaged. Before driving off again, press foot brake pedal, check the surrounding area near your vehicle and release parking brake manually with the EPB switch.

- If the AUTO HOLD indicator changes to yellow, the Auto Hold is not working properly. We recommend that you contact an authorized HYUNDAI dealer.
- While operating Auto Hold, you may hear mechanical noise. However, it is normal operating noise.

## WARNING

- Press the accelerator pedal slowly when you start the vehicle.
- For your safety, cancel the Auto Hold when you drive downhill, back up the vehicle or park the vehicle.

### NOTICE

If there is a malfunction with the driver's door, engine hood or trunk open detection system, the Auto Hold may not work properly. We recommend that you contact an authorized HYUNDAI dealer.

## Warning messages



Parking brake  
automatically  
applied

OTLE058242

### Parking brake automatically applied

When the EPB is applied from Auto Hold, a warning will sound and a message will appear.



Deactivating  
AUTO HOLD...  
Press brake pedal

OTLE058241

### Deactivating AUTO HOLD..

#### Press brake pedal

When the conversion from Auto Hold to EPB is not working properly a warning will sound and a message will appear.

### NOTICE

When this message is displayed, the Auto Hold and EPB may not operate. For your safety, depress the brake pedal.

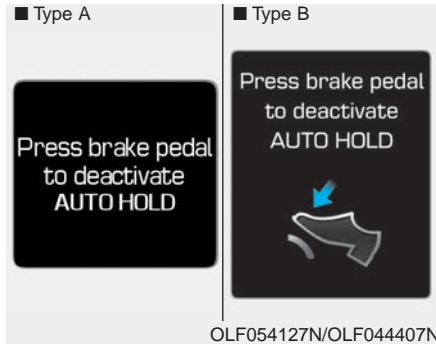

### Press brake pedal to deactivate AUTO HOLD

If you did not apply the brake pedal when you release the Auto Hold by pressing the [AUTO HOLD] switch, a warning will sound and a message will appear.



### AUTO HOLD conditions not met. Close door, hood, tailgate; fasten seatbelt

When you press the [AUTO HOLD] switch, if the driver's door, engine hood and tailgate are not closed or the driver's seat belt is unfastened, a warning will sound and a message will appear on the LCD display. At this moment, press the [AUTO HOLD] button after closing the driver's door, engine hood and tailgate and fastening the seat belt.

## Anti-lock Brake System (ABS)

### ⚠ WARNING

An Anti-Lock Braking System (ABS) or an Electronic Stability Control (ESC) system will not prevent accidents due to improper or dangerous driving maneuvers. Even though vehicle control is improved during emergency braking, always maintain a safe distance between you and objects ahead of you. Vehicle speeds should always be reduced during extreme road conditions. The braking distance for cars equipped with ABS or ESC may be longer than for those without these systems in the following road conditions.

- Drive your vehicle at reduced speeds during the following conditions:
- Rough, gravel or snow-covered roads.

(Continued)

**(Continued)**

- **On roads where the road surface is pitted or has different surface height.**
- **Tire chains are installed on your vehicle.**

**The safety features of an ABS or ESC equipped vehicle should not be tested by high speed driving or cornering. This could endanger the safety of yourself or others.**

ABS is an electronic braking system that helps prevent a braking skid. ABS allows the driver to steer and brake at the same time.

**Using ABS**

To obtain the maximum benefit from your ABS in an emergency situation, do not attempt to modulate your brake pressure and do not try to pump your brakes. Depress your brake pedal as hard as possible.

When you apply your brakes under conditions which may lock the wheels, you may hear sounds from the brakes, or feel a corresponding sensation in the brake pedal. This is normal and it means your ABS is active.

ABS does not reduce the time or distance it takes to stop the vehicle.

Always maintain a safe distance from the vehicle in front of you.

ABS will not prevent a skid that results from sudden changes in direction, such as trying to take a corner too fast or making a sudden lane change. Always drive at a safe speed for the road and weather conditions.

ABS cannot prevent a loss of stability. Always steer moderately when braking hard. Severe or sharp steering wheel movement can still cause your vehicle to veer into oncoming traffic or off the road.

On loose or uneven road surfaces, operation of the anti-lock brake system may result in a longer stopping distance than for vehicles equipped with a conventional brake system.

The ABS warning light () will stay on for several seconds after the Engine Start/Stop button is in the ON position. During that time, the ABS will go through self-diagnosis and the light will go off if everything is normal. If the light stays on, you may have a problem with your ABS. We recommend that you contact an authorized HYUNDAI dealer as soon as possible.

**⚠ WARNING**

If the ABS warning light (Ⓜ) is on and stays on, you may have a problem with the ABS. Your power brakes will work normally. To reduce the risk of serious injury or death, we recommend that you contact your HYUNDAI dealer as soon as possible.

**NOTICE**

When you drive on a road having poor traction, such as an icy road, and apply your brakes continuously, the ABS will be active continuously and the ABS warning light (Ⓜ) may illuminate. Pull your car over to a safe place and turn the engine off.

Restart the engine. If the ABS warning light is off, then your ABS system is normal.

Otherwise, you may have a problem with your ABS system. We recommend that you contact an authorized HYUNDAI dealer as soon as possible.

**i Information**

When you jump start your vehicle because of a drained battery, the ABS warning light (Ⓜ) may turn on at the same time. This happens because of the low battery voltage. It does not mean your ABS is malfunctioning. Have the battery recharged before driving the vehicle.

**Electronic Stability Control (ESC) (if equipped)**

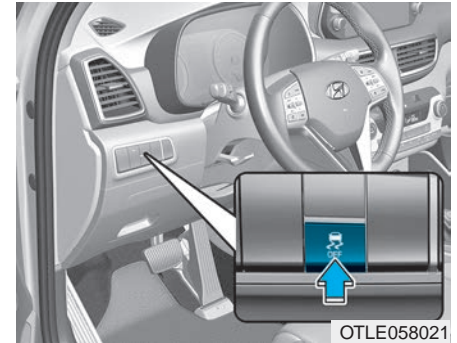

The Electronic Stability Control (ESC) system helps to stabilize the vehicle during cornering maneuvers.

ESC checks where you are steering and where the vehicle is actually going. ESC applies braking pressure to any one of the vehicle's brakes and intervenes in the engine management system to assist the driver with keeping the vehicle on the intended path. It is not a substitute for safe driving practices. Always adjust your speed and driving to the road conditions.

## WARNING

**Never drive too fast for the road conditions or too quickly when cornering. The ESC system will not prevent accidents.**

**Excessive speed in turns, abrupt maneuvers, and hydroplaning on wet surfaces can result in severe accidents.**

### **ESC operation**

#### **ESC ON condition**

When the ignition switch is in the ON position, the ESC and the ESC OFF indicator lights illuminate for approximately three seconds and goes off, then the ESC is turned on.

### **When operating**



When the ESC is in operation, the ESC indicator light blinks:

- When you apply your brakes under conditions which may lock the wheels, you may hear sounds from the brakes, or feel a corresponding sensation in the brake pedal. This is normal and it means your ESC is active.
- When the ESC activates, the engine may not respond to the accelerator as it does under routine conditions.
- If the Cruise Control was in use when the ESC activates, the Cruise Control automatically disengages. The Cruise Control can be reengaged when the road conditions allow. **See “Cruise Control System” later in this chapter.** (if equipped)

- When moving out of the mud or driving on a slippery road, the engine rpm (revolutions per minute) may not increase even if you press the accelerator pedal deeply. This is to maintain the stability and traction of the vehicle and does not indicate a problem.

### ESC OFF condition



To cancel ESC operation :

- State 1

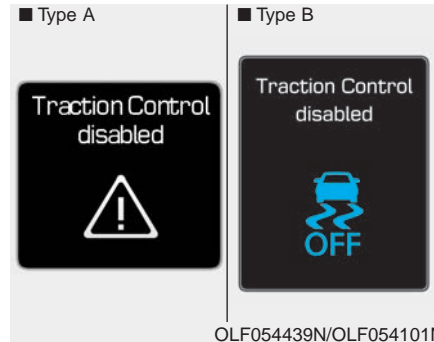

Press the ESC OFF button shortly (ESC OFF indicator light and message illuminates). At this state, the engine control function does not operate. The traction control function does not operate but only the brake control function operates.

- State 2

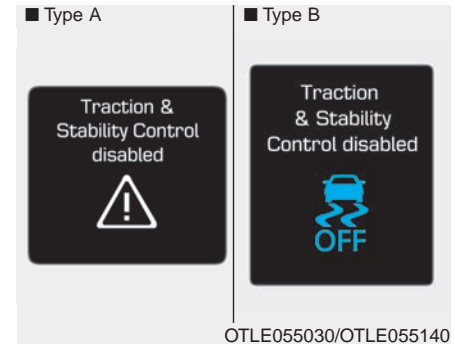

Press the ESC OFF button for more than 3 seconds. ESC OFF indicator light and message illuminates and ESC OFF warning chime will sound. At this state, the engine control function and brake control function does not operate. The vehicle stability control function does not operate any more.

If the ignition switch is placed to the LOCK/OFF position when ESC is off, ESC remains off. Upon restarting the engine, the ESC will automatically turn on again.



## Indicator lights

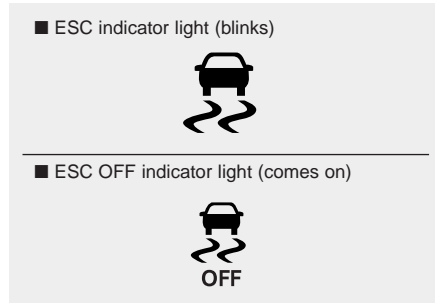

When the ignition switch is pressed to the ON position, the ESC indicator light illuminates, then goes off if the ESC system is operating normally.

The ESC indicator light blinks whenever the ESC is operating.

If ESC indicator light stays on, your vehicle may have a malfunction with the ESC system. When this warning light illuminates we recommend that the vehicle be checked by an authorized HYUNDAI dealer as soon as possible.

The ESC OFF indicator light comes on when the ESC is turned off with the button.

### WARNING

**When the ESC is blinking, this indicates the ESC is active:**

**Drive slowly and NEVER attempt to accelerate. NEVER turn the ESC off while the ESC indicator light is blinking or you may lose control of the vehicle resulting in an accident.**

### NOTICE

**Driving with tires or wheels in various sizes may fail the normal operation of the ESC system. Before replacing tires, make sure they are in the same size as others. Never drive the vehicle, which is installed with the tires of different diameters.**

## ESC OFF usage

### When Driving

The ESC OFF mode should only be used briefly to help free the vehicle if stuck in snow or mud by temporarily stopping operation of the ESC to maintain wheel torque.

To turn ESC off while driving, press the ESC OFF button while driving on a flat road surface.

### NOTICE

To prevent damage to the transaxle:

- Do not allow wheel(s) of one axle to spin excessively while the ESC, ABS, and parking brake warning lights are displayed. The repairs would not be covered by the vehicle warranty. Reduce engine power and do not spin the wheel(s) excessively while these lights are displayed.
- When operating the vehicle on a dynamometer, make sure the ESC is turned off (ESC OFF light illuminated).

### **i** Information

Turning the ESC off does not affect ABS or standard brake system operation.

## Vehicle Stability Management (if equipped)

Vehicle Stability Management (VSM) helps ensure the vehicle stays stable when accelerating or braking suddenly on wet, slippery and rough roads where traction over the four tires can suddenly become uneven.

### WARNING

Take the following precautions when using the Vehicle Stability Management (VSM):

- ALWAYS check the speed and the distance to the vehicle ahead. The VSM is not a substitute for safe driving practices.
- Never drive too fast for the road conditions. The VSM system will not prevent accidents. Excessive speed in bad weather, slippery and uneven roads can result in severe accidents.

## VSM operation

### VSM ON condition

The VSM operates when:

- The Electronic Stability Control (ESC) is on.
- Vehicle speed is approximately above 15 km/h (9 mph) on curve roads.
- Vehicle speed is approximately above 20 km/h (12 mph) when the vehicle is braking on rough roads.

### When operating

When you apply your brakes under conditions which may activate the ESC, you may hear sounds from the brakes, or feel a corresponding sensation in the brake pedal. This is normal and it means your VSM is active.

## **i** Information

The VSM does not operate when:

- Driving on bank road such as gradient or incline
- Driving rearward.
- ESC OFF indicator light is on.
- EPS (Electric Power Steering) warning light (⚠) is on.

### VSM OFF condition

To cancel VSM operation, press the ESC OFF button. ESC OFF indicator light (OFF) will illuminate.

To turn on VSM, press the ESC OFF button again. The ESC OFF indicator light will go out.

### **⚠ WARNING**

If ESC indicator light (⚠) or EPS warning light (⚠) stays on, your vehicle may have a malfunction with the VSM system. When the warning light illuminates we recommend that the vehicle be checked by an authorized HYUNDAI dealer as soon as possible.

### **NOTICE**

Driving with varying tire or wheel sizes may cause the ESC system to malfunction. When replacing tires, make sure they are the same size as your original tires for this vehicle.

### Hill-Start Assist Control (HAC) (if equipped)

A vehicle has the tendency to slide backwards on a steep slope, before depressing the accelerator after a stop. The HAC prevents the vehicle from sliding backwards by automatically operating the brake systems for about 2 seconds. The brake systems are automatically released, when the accelerator pedal is depressed

### **⚠ WARNING**

The HAC is activated only for about 2 seconds, so always depress the accelerator pedal to begin driving upwards after a stop.

**i** Information

- The HAC does not operate when the shift lever is in P (Park) or N (Neutral).
- The HAC activates even when the ESC (Electronic Stability Control) is off. However, it does not activate, when the ESC does not normally operate.

**Downhill Brake Control (DBC)  
(if equipped)**

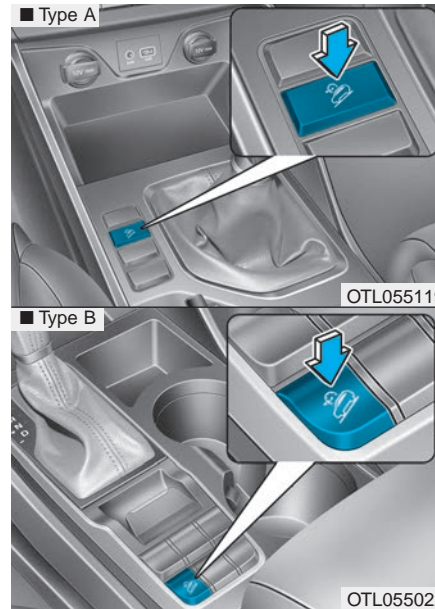

The Downhill Brake Control (DBC) supports the driver come down a steep hill without depressing the brake pedal.





It slows down the vehicle under 8 km/h (5 mph) (for automatic transaxle /dual clutch transmission vehicles) or 8 km/h (5 mph) (for manual transaxle vehicles) and lets the driver concentrate on steering the vehicle.

**⚠ WARNING**

**Always turn off the DBC on normal roads. The DBC might activate inadvertently from the standby mode when driving through speed bumps or making sharp curves.**

- NOTICE**
- The DBC defaults to the OFF position whenever the ignition switch is placed in the ON position.
  - Noise or vibration may occur from the brakes when the DBC is activated.
  - The rear stop light comes on when DBC is activated.

## DBC operation

Mode	Indicator light	Description
Standby	 illuminated	Press the DBC button when vehicle speed is under 40 km/h (25 mph). The DBC system will turn ON and enter the standby mode.  The system does not turn ON if vehicle speed is over 40 km/h (25 mph).
Activated	 blinks	In the standby mode, if vehicle speed is under 35 km/h (22 mph) while driving down a steep hill, the DBC will activate automatically.
Temporarily deactivated	 illuminated	In the activated mode, the DBC will temporarily deactivate under the following conditions: <ul style="list-style-type: none"> <li>• The hill is not steep enough.</li> <li>• The brake pedal or accelerator pedal is depressed.</li> </ul> If the above conditions are gone, the DBC will automatically activate again.
OFF	 not illuminated	The DBC will turn OFF under the following conditions: <ul style="list-style-type: none"> <li>• The DBC button is pressed again.</li> <li>• Vehicle speed is over 60 km/h (38 mph).</li> </ul>

### WARNING

If the DBC red indicator light illuminates, the system may have overheated or have malfunctioned. When the warning light illuminates even though the DBC system has cooled off, we recommend that the vehicle be checked by an authorized HYUNDAI dealer as soon as possible.

### NOTICE

- The DBC may not deactivate on steep inclines even though the brake or accelerator pedal is depressed.
- Do not turn on the DBC when driving with shift lever in 3rd gear (and above) for vehicles with manual transaxle. The engine may stop if the DBC system is activated.
- The DBC does not operate when:
  - The shift lever is in P (Park).
  - The ESC is activated.

### Low Vacuum Assist (LVA) (if equipped)

Low Vacuum Assist (LVA) amplifies the hydraulic brake force to assist the driver under low or temporarily low engine vacuum. You may hear a motor running sound and feel a slight vibration in the brake pedal like ABS operating. This indicates that the Supplemental Brake Assist system is working to maintain braking power.

#### **WARNING**

**Low Vacuum Assist (LVA) will not prevent accidents due to improper or dangerous driving maneuvers.**

### Emergency Stop Signal (ESS) (if equipped)

The Emergency Stop Signal system alerts the driver behind by blinking the stop lights, while sharply and severely braking.

The system is activated when:

- The vehicle suddenly stops. (The deceleration power exceeds  $7 \text{ m/s}^2$ , and the driving speed exceeds  $55 \text{ km/h}$  ( $34 \text{ mph}$ .)
- The ABS is activated.

The hazard warning flasher automatically turns ON after blinking the stop lights, when the driving speeds is decelerated under  $40 \text{ km/h}$  ( $25 \text{ mph}$ ), when the ABS is deactivated, and when the sudden braking situation is over.

The hazard warning flasher turns OFF, when the driving speed exceeds  $10 \text{ km/h}$  ( $6 \text{ mph}$ ) after a complete stop. The hazard warning flasher turns OFF, when the vehicle drives at a low speed for a certain period of time. The driver can manually turn OFF the hazard warning flasher by pressing the button.

#### **Information**

**The Emergency Stop Signal (ESS) system will not activate, when the hazard warning flasher already blinks.**

## Good braking practices

### ⚠ WARNING

**Whenever leaving the vehicle or parking, always come to a complete stop and continue to depress the brake pedal. Move the shift lever into the P (Park) position, then apply the parking brake, and place the Engine Start/Stop button in the OFF position.**

**Vehicles with the parking brake not fully engaged are at risk for moving inadvertently and causing injury to yourself or others.**

Wet brakes can be dangerous! The brakes may get wet if the vehicle is driven through standing water or if it is washed. Your vehicle will not stop as quickly if the brakes are wet. Wet brakes may cause the vehicle to pull to one side.

To dry the brakes, apply the brakes lightly until the braking action returns to normal, taking care to keep the vehicle under control at all times. If the braking action does not return to normal, stop as soon as it is safe to do so and we recommend that you call an authorized HYUNDAI dealer for assistance.

DO NOT drive with your foot resting on the brake pedal. Even light, but constant pedal pressure can result in the brakes overheating, brake wear, and possibly even brake failure.

If a tire goes flat while you are driving, apply the brakes gently and keep the vehicle pointed straight ahead while you slow down. When you are moving slowly enough for it to be safe to do so, pull off the road and stop in a safe location.

Keep your foot firmly on the brake pedal when the vehicle is stopped to prevent the vehicle from rolling forward.

## FOUR WHEEL DRIVE (4WD) (IF EQUIPPED)

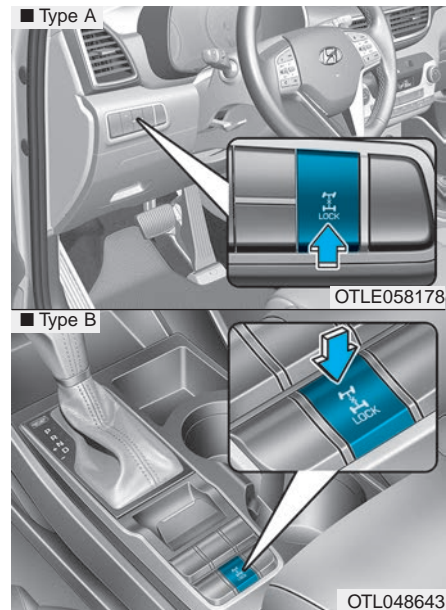

The Four Wheel Drive (4WD) System delivers engine power to all front and rear wheels for maximum traction. 4WD is useful when extra traction is required on roads such as slippery, muddy, wet, or snow-covered roads.

Occasional off-road use such as established unpaved roads and trails are OK. It is always important that the driver carefully reduces the speed to a level that does not exceed the safe operating speed for those conditions.

### **WARNING**

#### **To reduce the risk of SERIOUS INJURY or DEATH:**

- Do not drive in conditions that exceed the vehicles intended design such as challenging off-road conditions.
- Avoid high speeds when cornering or turning.
- Do not make quick steering wheel movements, such as sharp lane changes or fast, sharp turns.
- The risk of a rollover is greatly increased if you lose control of your vehicle at highway speeds.
- Loss of control often occurs if two or more wheels drop off the roadway and the driver over steers to reenter the roadway.
- In the event your vehicle leaves the roadway, do not steer sharply. Instead, slow down before pulling back into the travel lanes.



### **NOTICE**

- Do not drive in water if the level is higher than the bottom of the vehicle.
- Check your brake condition once you are out of mud or water. Depress the brake pedal several times as you move slowly until you feel normal braking return.
- Shorten your scheduled maintenance interval if you drive in off-road conditions such as sand, mud or water (see "Maintenance Under Severe Usage Conditions" in chapter 7).
- Always wash your vehicle thoroughly after off road use, especially the bottom of the vehicle.
- Be sure to equip the vehicle with four tires of the same size and type.
- Make sure that a full time 4WD vehicle is towed by a flat bed tow truck.





## 4WD operation

### Four Wheel Drive (4WD) mode selection

Transfer mode	Selection button	Indicator light	Description
<b>4WD AUTO</b> (4WD LOCK is deactivated)		 LOCK (not illuminated)	<ul style="list-style-type: none"> <li>• 4WD Auto is used when driving on roads in normal conditions, roads in urban areas, and on highways.</li> <li>• All wheels are in operation when a vehicle travels at a constant speed. Required tractions applying on front and rear wheels vary depending on road driving conditions and driving conditions, which will be automatically controlled by the computing system.</li> <li>• When the cluster's 4WD Auto display mode is selected, the cluster displays the status of how four wheels' traction forces are distributed.</li> </ul>
<b>4WD LOCK</b>		 LOCK (illuminated)	<ul style="list-style-type: none"> <li>• The main goal of 4WD Lock mode is to allow a driver to maximize the vehicle's traction under extreme driving conditions such as unpaved off-road, sandy roads, and muddy roads.</li> <li>• 4WD Lock mode is in operation only when a vehicle travels at 60 km/h or less. When traveling at 60 km/h or faster, the mode will switch to 4WD Auto.</li> <li>• When 4WD Lock mode illuminates, the cluster does not display the front/rear wheel traction force distribution status.</li> <li>• Press the 4WD Lock mode switch again to switch back to 4WD Auto.</li> </ul>

**⚠ WARNING**

If 4WD warning light (  ) stays on the instrument cluster, your vehicle may have a malfunction with the 4WD system. When the 4WD warning light (  ) illuminates we recommend that the vehicle be checked by an authorized HYUNDAI dealer as soon as possible.

**NOTICE**

- Maintain 4WD Auto mode when driving on roads in normal conditions.
- When driving under normal road conditions (especially when cornering) in 4WD Lock mode, a driver may find minor mechanical vibration or noise, which is extremely normal phenomenon, not a malfunction. When 4WD Lock mode is released, such noise or vibration will be immediately gone.

**⚠ CAUTION**

When driving on normal roads, deactivate the 4WD LOCK mode by pushing the 4WD LOCK button (4WD LOCK indicator light goes off). Driving on normal roads with the 4WD LOCK mode, especially, when cornering may cause mechanical noise or vibration. The noise and vibration will disappear when the 4WD LOCK mode is deactivated. Prolong driving with the noise and vibration may damage some parts of the power train.

When the 4WD LOCK mode is deactivated, a sensation may be felt as the driving power is delivered entirely to the front wheels.

**For safe 4WD operation**

**Before driving**

- Make sure all passengers are wearing seat belts.
- Sit upright and closer to the steering wheel than usual. Adjust the steering wheel to a position comfortable for you to drive.

**Driving on snow-covered or icy roads**

- Start off slowly by applying the accelerator pedal gently.
- Use snow tires or tire chains.
- Keep sufficient distance between your vehicle and the vehicle in front of you.
- Use engine braking during deceleration.
- Avoid speeding, rapid acceleration, sudden brake applications, and sharp turns to prevent skids.

### Driving in sand or mud

- Maintain slow and constant speed.
- Use tire chains driving in mud if necessary.
- Keep sufficient distance between your vehicle and the vehicle in front of you.
- Reduce vehicle speed and always check the road condition.
- Avoid speeding, rapid acceleration, sudden brake applications, and sharp turns to prevent getting stuck.



### CAUTION

**When the vehicle is stuck in snow, sand or mud, place a non-slip material under the drive wheels to provide traction OR Slowly spin the wheels in forward and reverse directions which causes a rocking motion that may free the vehicle. However, avoid running the engine continuously at high rpm, doing so may damage the 4WD system.**

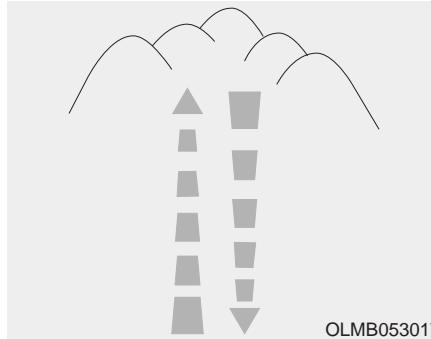

### Driving up or down hills

- Driving uphill
  - Before starting off, check if it is possible to drive uphill.
  - Drive as straight as possible.
- Driving downhill
  - Do not change gear while driving downhill. Select gear before driving downhill.
  - Drive as slowly using engine braking while driving downhill.
  - Drive straight as possible.



### WARNING

**Exercise extreme caution driving up or down steep hills. The vehicle may flip depending on the grade, terrain and water/mud conditions.**



### **⚠ WARNING**

**Do not drive across the contour of steep hills. A slight change in the wheel angle can destabilize the vehicle, or a stable vehicle may lose stability if the vehicle stops its forward motion. Your vehicle may roll over and lead to a serious injury or death.**

### **Driving through water**

- Try to avoid driving in deep standing water. It may stall your engine and clog your exhaust pipes.
- If you need to drive in water, stop your vehicle, set the vehicle in 4WD LOCK mode and drive under 8 km/h (5 mph).
- Do not change gear while driving in water.

### **⚠ CAUTION**

**Always drive slowly in water. If you drive too fast, water may get into the engine compartment and wet the ignition system causing your vehicle to suddenly stop.**

### **Additional driving conditions**

- Become familiar with the off-road conditions before driving.
- Always pay attention when driving off-road and avoid dangerous areas.
- Drive slowly when driving in heavy wind.
- Reduce vehicle speed when cornering. The center of gravity of 4WD vehicles is higher than conventional 2WD vehicles, making them more likely to roll over when you rapidly turn corners.



OTLE055003

- Always hold the steering wheel firmly when you are driving off-road.

### **⚠ WARNING**

**Do not grab the inside of the steering wheel when you are driving off-road. You may hurt your arm by a sudden steering maneuver or from steering wheel rebound due to an impact with objects on the ground. You could lose control of the steering wheel which may lead to serious injury or death.**

## **Emergency precautions**

### **Tires**

Do not use tire and wheel with different size and type from the one originally installed on your vehicle. It can affect the safety and performance of your vehicle, which could lead to steering failure or rollover causing serious injury.

When replacing the tires, be sure to equip all four tires with the tire and wheel of the same size, type, tread, brand and load-carrying capacity. If you equip your vehicle with any tire/wheel combination not recommended by HYUNDAI for off-road driving, you should not use these tires for highway driving.

### **⚠ WARNING**

**Never start or run the engine while a full-time 4WD vehicle is raised on a jack. The vehicle can slip or roll off of a jack causing serious injury or death to you or those nearby.**

### **Towing**

4WD vehicles must be towed with a wheel lift and dollies or flatbed equipment with all the wheels off the ground. For more details, refer to "Towing" in chapter 6.

### **Dynamometer testing**

A full-time 4WD vehicle must be tested on a special four wheel chassis dynamometer.

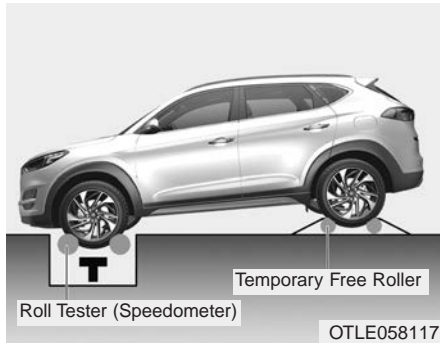

A full-time 4WD vehicle should not be tested on a 2WD roll tester. If a 2WD roll tester must be used, perform the following procedure:

1. Check the tire pressures recommended for your vehicle.
2. Place the front wheels on the roll tester for a speedometer test as shown in the illustration.
3. Release the parking brake.
4. Place the rear wheels on the temporary free roller as shown in the illustration.

### CAUTION

- **Never engage the parking brake while performing the test.**
- **When the vehicle is lifted up, do not operate the front and rear wheel separately. All four wheels should be operated.**

### WARNING

**Keep away from the front of the vehicle while the vehicle is in gear on the dynamometer. The vehicle can jump forward and cause serious injury or death.**

## Reducing the risk of a rollover

This multi-purpose passenger vehicle is defined as a Sports Utility Vehicle (SUV). SUV's have higher ground clearance and a narrower track to make them capable of performing in a wide variety of off-road applications. Specific design characteristics give them a higher center of gravity than ordinary vehicles. An advantage of the higher ground clearance is a better view of the road, which allows you to anticipate problems. They are not designed for cornering at the same speeds as conventional passenger vehicles, any more than low-slung sports cars are designed to perform satisfactorily in off-road conditions. Due to this risk, driver and passengers are strongly recommended to buckle their seat belts. In a rollover crash, an unbelted person is more likely to die than a person wearing a seat belt. There are steps that a driver can make to reduce the risk of a rollover. If at all possible, avoid sharp turns or abrupt maneuvers, do not load your roof rack with heavy cargo, and never modify your vehicle in any way.

## WARNING

### Rollover

As with other Sports Utility Vehicle (SUV), failure to operate this vehicle correctly may result in loss of control, an accident or vehicle rollover.

- Utility vehicles have a significantly higher rollover rate than other types of vehicles.
- Specific design characteristics (higher ground clearance, narrower track, etc.) give this vehicle a higher center of gravity than ordinary vehicles.
- A SUV is not designed for cornering at the same speeds as conventional vehicles.
- Avoid sharp turns or abrupt maneuvers.
- In a rollover crash, an unbelted person is significantly more likely to die than a person wearing a seat belt. Make sure everyone in the vehicle is properly buckled up.

## WARNING

Your vehicle is equipped with tires designed to provide safe ride and handling capability. Do not use a size and type of tire and wheel that is different from the one that is originally installed on your vehicle. It can affect the safety and performance of your vehicle, which could lead to steering failure or rollover and serious injury. When replacing the tires, be sure to equip all four tires with the tire and wheel of the same size, type, tread, brand and load-carrying capacity. If you nevertheless decide to equip your vehicle with any tire/wheel combination not recommended by HYUNDAI for off road driving, you should not use these tires for highway driving.

## WARNING

### Jacked vehicle

While a full-time 4WD vehicle is being raised on a jack, never start the engine or cause the tires to rotate.

There is a danger that rotating tires touching the ground could cause the vehicle to fall off the jack and to jump forward or rearward.

### ISG (IDLE STOP AND GO) SYSTEM (IF EQUIPPED)

The ISG system is to reduce the fuel consumption by automatically shutting down the engine, when the vehicle is at a standstill (i.e. red stop light, stop sign, and traffic jam).

The engine is automatically started upon satisfying the starting conditions.

The ISG system is always active, when the engine is running.

#### **i** Information

**When the engine is automatically started by the ISG system, some warning lights (i.e. ABS, ESC, ESC OFF, EPS, and parking brake warning light) may illuminate for a few seconds due to the low battery voltage. However, it does not indicate a malfunction with the ISG system.**

#### To activate the ISG system

##### **Prerequisite for activation**

The ISG system operates in the following situations.

- The driver's seatbelt is fastened.
- The driver's door and the hood are closed.
- The brake vacuum pressure is adequate.
- The battery is sufficiently charged.
- The outside temperature is between -10 °C and 35 °C (14 °F and 95 °F).
- The engine coolant temperature is not too low.
- The system is not in the diagnostic mode.
- The steering wheel is not steered excessively. (for automatic transmission vehicle)
- The vehicle is driven on a steep incline. (for automatic transmission vehicle)

#### **i** Information



- **The ISG system is not activated, when the prerequisites to activate the ISG system are unsatisfied. In this case, the ISG OFF button indicator illuminates, and the auto stop indicator ((A)) illuminates in yellow on the instrument cluster.**
- **When the above indicator remains illuminated on the instrument cluster, we recommend that you have the ISG system checked by an authorized HYUNDAI dealer.**



## Auto stop

**To stop the engine in idle stop mode**

**Manual transmission vehicle**

1. Decrease the vehicle speed to 5 km/h (3 mph).
2. Set the gear in N (Neutral).
3. Release the clutch pedal.

The auto stop indicator ((A)) illuminates in green on the instrument cluster, when the engine stops.

## **i** Information

The driving speed must reach at least 10 km/h (6 mph) after an idle stop to stop the engine in idle stop mode again.

**Automatic transmission vehicle**

1. Decrease the vehicle speed to 0 km/h.
2. Depress the brake pedal with the shift lever in D (Drive) or N (Neutral).

The auto stop indicator ((A)) illuminates in green on the instrument cluster, when the engine stops.

## **i** Information

The driving speed must reach at least 8 km/h (5 mph) after an idle stop to stop the engine in idle stop mode again.

In auto stop mode, when the driver opens the hood, the ISG system will be deactivated.

When the system is deactivated:

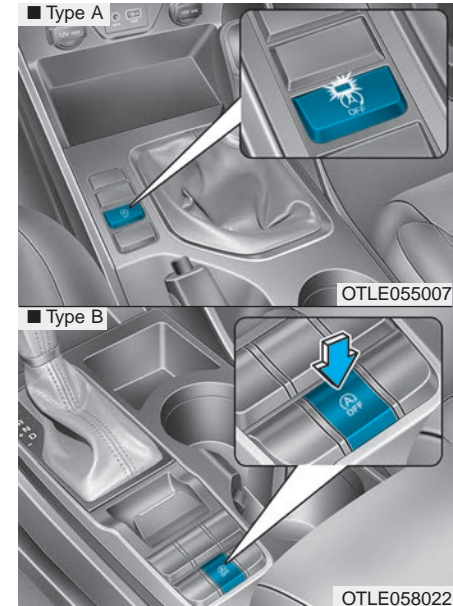

The ISG OFF button indicator illuminates.

At this time, restart the vehicle manually by:

### **Manual transmission vehicle**

Depressing the clutch and brake pedal with the gear in neutral.

### **Automatic transmission vehicle**

Depressing the brake pedal with the shift lever in P (Park) or N (Neutral). But for your safety, restart the vehicle in the P (Park) position.

### **Auto start**

**To restart the engine in the auto stop mode**

#### **Manual transmission vehicle**

- Depress the clutch pedal with the gear in N (Neutral).

The auto stop indicator ((A)) goes OFF on the instrument cluster, when the engine is restarted.

#### **Automatic transmission vehicle**

- Release the brake pedal.
- When Auto Hold is activated, if you release the brake pedal, the engine will be in the auto stop state. However, if you depress the accelerator pedal, the engine will start again.

The auto stop indicator ((A)) goes OFF on the instrument cluster, when the engine is restarted.

**The engine is automatically restarted in the following situations.**

- The fan speed of the manual climate control system is set above the 3rd position, with the air condition ON.
- The fan speed of the automatic climate control system is set above the 6th position, with the air condition ON.
- A certain period of time has elapsed with the air condition ON.
- The defroster is activated.
- The brake vacuum pressure is low.
- The battery is weak.
- The driving speed exceeds 5 km/h (3 mph). (for manual transmission vehicle)
- The driving speed exceeds 2 km/h (1.2 mph). (for automatic transmission vehicle)
- The vehicle is shifted to P (Park) or R (Reverse) when the brake pedal is depressed.

- The door is opened or seat belt is unfastened when the brake pedal is depressed.

The auto stop indicator (A) blinks in green for 5 seconds on the instrument cluster and a message "Auto Start" will appear on the LCD display.

**The auto start is temporarily deactivated in the following situations.**



#### **Manual transmission vehicle**

When the gear is shifted without the clutch pedal depressed. A message "Press clutch pedal for Auto Start" will appear on the LCD display. To activate auto start, shift to neutral and depress the clutch pedal.

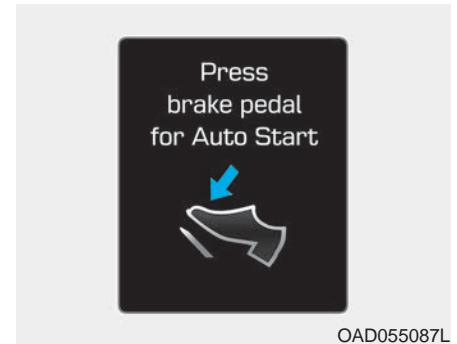

#### **Automatic transmission vehicle**

When the shift lever is shifted from N (Neutral) to R (Reverse), D (Drive) or Manual shift mode without the brake pedal depressed. A message "Press brake pedal for Auto Start" will appear on the LCD display. To activate auto start, depress the brake pedal.

### To deactivate the ISG system

- Press the ISG OFF button to deactivate the ISG system. Then, the ISG OFF button indicator illuminates, and the message "Auto Stop System Off" appears on the LCD display.
- Press the ISG OFF button again to reactivate the ISG system. Then, the ISG OFF button indicator turns OFF.

### ISG system malfunction

The ISG system may not operate:

When there is a malfunction with the ISG sensors or the ISG system.

The followings occur, when there is a malfunction with the ISG system:

- The auto stop indicator ((A)) will blink in yellow on the instrument cluster.
- The light on the ISG OFF button will illuminate.

### Information

- When you cannot turn OFF the ISG OFF button indicator by pressing the ISG OFF button, or when the malfunction with the ISG system persists, we recommend that you contact an authorized HYUNDAI dealer.
- You can turn off the ISG OFF button indicator by driving over 80 km/h (50 mph) for up to 2 hours with the fan speed below the 2nd position. If the ISG OFF button indicator remains ON, we recommend that you contact an authorized HYUNDAI dealer.

### WARNING

**When the engine is in auto stop mode, the engine may restart. Before leaving the vehicle or checking the engine compartment, stop the engine by placing the ignition switch to the LOCK/OFF position or removing the ignition key.**

## The battery sensor deactivation

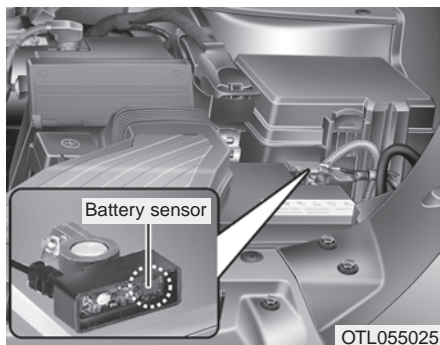

The battery sensor is deactivated, when the battery is disconnected from the negative pole for maintenance purpose.

In this case, the ISG system is limitedly operated due to the battery sensor deactivation. Thus, the driver needs to take the following procedures to reactivate the battery sensor after disconnecting the battery.

### ***Prerequisites to reactivate the battery sensor***

Keep the engine in the OFF status for 4 hours, and attempt to restart the engine 3 to 4 times for the battery-sensor reactivation.

Pay extreme caution not to connect any accessories (i.e. navigation and black box) to the vehicle with the engine in the OFF status. If not, the battery sensor may not be reactivated.

### ***i* Information**

**The ISG system may not operate in the following situations.**

- There is a malfunction with the ISG system.
- The battery is weak.
- The brake vacuum pressure is low.

**In those cases, we recommend that you have the ISG system checked by an authorized HYUNDAI dealer.**

### **NOTICE**

- Use only the genuine HYUNDAI ISG battery for replacement. If not, the ISG system may not normally operate.
- Do not recharge the ISG battery with a general battery charger. If not, it may damage or explode the ISG battery.
- Do not remove the battery cap. If not, the battery electrolyte, which is harmful to the human body, may leak out.

## FLEX STEERING WHEEL (IF EQUIPPED)

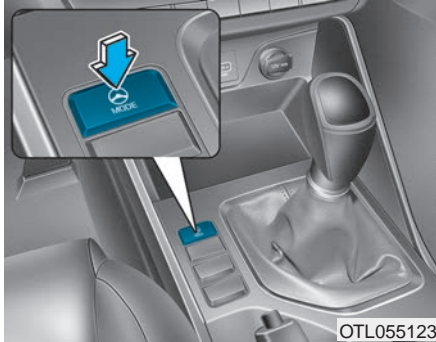

The flex steering wheel controls the steering effort in accordance with the driver's preference and road conditions.

The driver can select a desired steering effort by pressing the steering mode button.

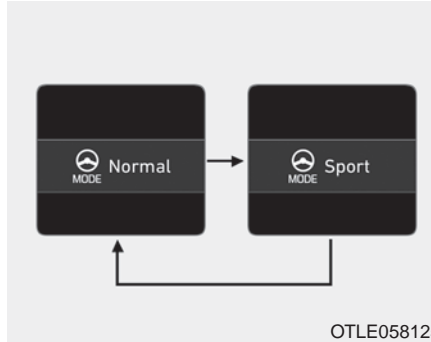

The steering mode options appear on the LCD display, when the driver presses the steering mode button.

Press the steering mode button within 4 seconds to scroll through the steering mode options.

If the steering mode button is not pressed within 4 seconds, the LCD display will change to the previous screen.

### *Normal mode*



The normal steering mode offers normal steering effort.

## ***Sport mode***

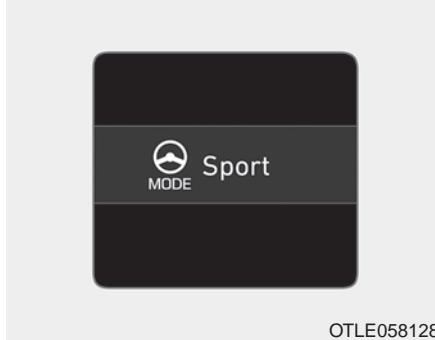

The sport steering mode offers high steering effort, making the wheel steering heavier. The sport steering mode is often used for driving on a highway.

### **⚠ CAUTION**

- When the driver presses the steering mode button while driving, it changes the steering mode option on the LCD display. However, it does not immediately change the steering effort for your safety. Upon completing the wheel steering, the steering tension is automatically set to the selected mode.
- Pay great caution while changing through modes, when the vehicle is in motion.
- The flex steering wheel does not operate, when the Electric Power Steering (EPS) does not properly operate.

## DRIVE MODE INTEGRATED CONTROL SYSTEM (IF EQUIPPED)

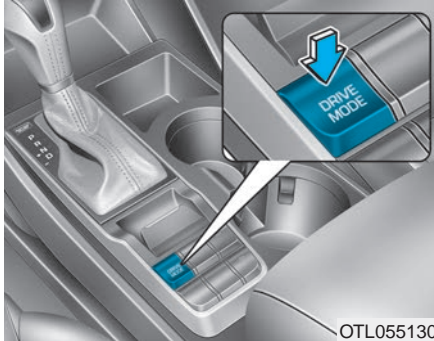

The drive mode may be selected according to the driver's preference or road condition.

The system resets to be in the COMFORT mode, when the engine is restarted.

### **i** Information

If there is a problem with the instrument cluster, the drive mode will be in COMFORT mode and may not change to SPORT mode.

The mode changes, as below, whenever the DRIVE MODE button is pressed.

SPORT ↔ COMFORT

When COMFORT mode is selected, it is not displayed on the instrument cluster.

### **SPORT mode**



SPORT mode manages the driving dynamics by automatically adjusting the steering wheel, engine and transaxle system.

- When the SPORT mode is selected by pressing the DRIVE MODE button, the SPORT indicator (yellow color) will illuminate.
- Restarting of the engine in the SPORT mode resets the DRIVE mode to the COMFORT mode. Thus, when necessary, reselect the SPORT mode.
- When the SPORT mode is activated:
  - The RPM (revolutions per minutes) level is maintained over a certain length of time, even after releasing the accelerator.
  - Up-shifting timing is delayed, while accelerating.

### **i** Information

In the SPORT mode, the fuel efficiency may decrease.



## FORWARD COLLISION-AVOIDANCE ASSIST (FCA) SYSTEM – SENSOR FUSION TYPE (FRONT RADAR + FRONT CAMERA) (IF EQUIPPED, EXCEPT MIDDLE EAST)

The Forward Collision-Avoidance Assist (FCA) system is designed to help detect and monitor the vehicle ahead or detect a pedestrian in the roadway through radar signals and camera recognition to warn the driver that a collision is imminent, and if necessary, apply emergency braking.

### WARNING

**Take the following precautions when using the Forward Collision-Avoidance Assist (FCA) system:**

- **This system is only a supplemental system and it is not intended to, nor does it replace the need for extreme care and attention of the driver. The sensing range and objects detectable by the sensors are limited. Pay attention to the road conditions at all times.**
- **NEVER drive too fast in accordance with the road conditions or while cornering.**
- **Always drive cautiously to prevent unexpected and sudden situations from occurring. FCA does not stop the vehicle completely and is not a collision avoidance system.**

### System setting and activation

#### System setting

- The driver can activate the FCA by placing the ignition switch to the ON position and by selecting:  
'User Settings → Driver assistance → Forward Collision-Avoidance Assist (FCA)'

The FCA deactivates, when the driver cancels the system setting.



The warning light illuminates on the LCD display, when you cancel the FCA system. The driver can monitor the FCA ON/OFF status on the LCD display. Also, the warning light illuminates when the ESC (Electronic Stability Control) is turned off. If the warning light remains ON when the FCA is activated, we recommend that you have the system checked by an authorized HYUNDAI dealer.

- The driver can select the initial warning activation time on the LCD display.

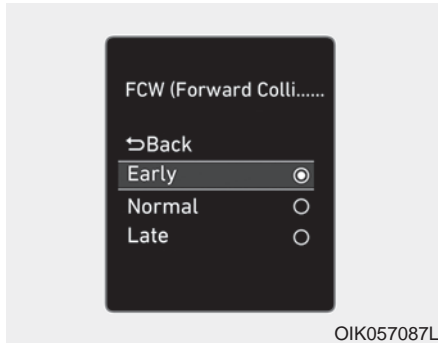

Go to the 'User Settings → Driver assistance → Forward Collision Warning → Early/Normal/Late'.

The options for the initial Forward Collision Warning includes the following:

- Early:

When this condition is selected, the initial Forward Collision Warning is activated earlier than normal. This setting maximizes the amount of distance between the vehicle or pedestrian ahead before the initial warning occurs.

Even though, 'Early' is selected if the front vehicle suddenly stops the initial warning activation time may not seem fast.

If you feel the warning activates too early, set the Forward Collision Warning to 'Normal'.

- Normal:

When this condition is selected, the initial Forward Collision Warning is activated normally. This setting allows for a nominal amount of distance between the vehicle or pedestrian ahead before the initial warning occurs.

- Late:

When this condition is selected, the initial Forward Collision Warning is activated later than normal. This setting reduces the amount of distance between the vehicle or pedestrian ahead before the initial warning occurs.

Select 'Late' when traffic is light and when driving speed is slow.

### ***Prerequisite for activation***

The FCA gets ready to be activated, when the FCA is selected on the LCD display, and when the following prerequisites are satisfied.

- The ESC (Electronic Stability Control) is on.
- Vehicle speed is over 8 km/h (5 mph). (The FCA is only activated within a certain speed range.)
- The system detects a pedestrian or a vehicle in front, which may collide with your vehicle. (The FCA may not be activated or may sound a warning alarm in accordance with the driving situation or vehicle condition.)

### **⚠ WARNING**

- **Completely stop the vehicle on a safe location before operating the switch on the steering wheel to activate/deactivate the FCA system.**
- **The FCA automatically activates upon placing the Engine Start/Stop button to the ON position. The driver can deactivate the FCA by canceling the system setting on the LCD display.**
- **The FCA automatically deactivates upon canceling the ESC (Electronic Stability Control). When the ESC is canceled, the FCA cannot be activated on the LCD display. The FCA warning light will illuminate which is normal.**

### **FCA warning message and system control**

The FCA produces warning messages and warning alarms in accordance with the collision risk levels, such as abrupt stopping of the vehicle in front, insufficient braking distance, pedestrian detection. Also, it controls the brakes in accordance with the collision risk levels.

The driver can select the initial warning activation time in the User Settings in the LCD display. The options for the initial Forward Collision Warning include Early, Normal or Late initial warning time.

### **Collision Warning (First warning)**



This warning message appears on the LCD display with a warning chime. Additionally, some vehicle system intervention occurs by the engine management system to help decelerate the vehicle.

- Your vehicle speed may decelerate moderately.
- The FCA system limitedly controls the brakes to preemptively mitigate impact in a collision.

- It will operate if the vehicle speed is greater than approximately 8 km/h (5 mph) and less than or equal to 180 km/h (110 mph) on a forward vehicle. (Depending on the condition of the vehicle ahead and the environment surrounding it, the possible maximum operating speed may be reduced.)

For pedestrians, the vehicle speed is greater than or equal to approximately 8 km/h (5 mph) and less than approximately 70 km/h (45 mph). (Depending on the condition of pedestrians and bike riders and the surrounding environment the possible maximum operating speed may be reduced.)

### **Emergency braking (Second warning)**



This warning message appears on the LCD display with a warning chime.

Additionally, some vehicle system intervention occurs by the engine management system to help decelerate the vehicle.

- The FCA system limitedly controls the brakes to preemptively mitigate impact in a collision. The brake control is maximized just before a collision.

- It will operate if the vehicle speed is greater than approximately 8 km/h (5 mph) and less than or equal to 80 km/h (50 mph) on a forward vehicle. (Depending on the condition of the vehicle ahead and the surrounding environment the possible maximum operating speed may be reduced.)

For pedestrians, the vehicle speed is greater than or equal to approximately 8 km/h (5 mph) and less than approximately 70 km/h (45 mph). (Depending on the condition of pedestrians and bike riders and the surrounding environment the possible maximum operating speed may be reduced.)

### **Brake operation**

- In an urgent situation, the braking system enters into the ready status for prompt reaction against the driver's depressing the brake pedal.
- The FCA provides additional braking power for optimum braking performance, when the driver depresses the brake pedal.
- The braking control is automatically deactivated, when the driver sharply depresses the accelerator pedal, or when the driver abruptly operates the steering wheel.
- The FCA brake control is automatically canceled, when risk factors disappear.

### CAUTION

The driver should always use extreme caution while operating the vehicle, whether or not there is a warning message or alarm from the FCA system.

### WARNING

The braking control cannot completely stop the vehicle nor avoid all collisions. The driver should hold the responsibility to safely drive and control the vehicle.

### WARNING

The FCA system logic operates within certain parameters, such as the distance from the vehicle or pedestrian ahead, the speed of the vehicle ahead, and the driver's vehicle speed. Certain conditions such as inclement weather and road conditions may affect the operation of the FCA system.

### WARNING

Never deliberately drive dangerously to activate the system.

### FCA sensor

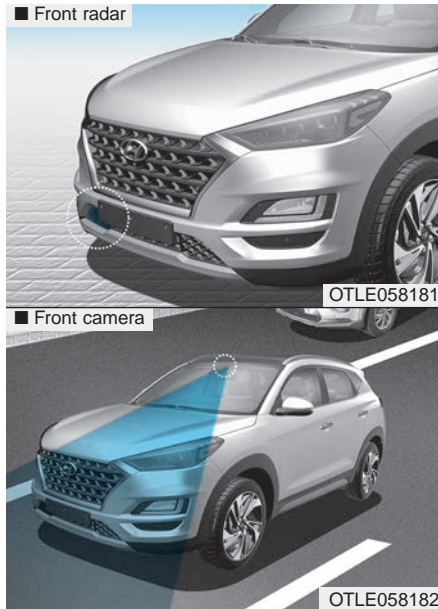

In order for the FCA system to operate properly, always make sure the sensor cover or sensor is clean and free of dirt, snow, and debris.

Dirt, snow, or foreign substances on the lens may adversely affect the sensing performance of the sensor.

#### **NOTICE**

- Do not apply license plate molding or foreign objects such as a bumper sticker or a bumper guard near the radar sensor. Doing so may adversely affect the sensing performance of the radar.
- Always keep the radar sensor and cover clean and free of dirt and debris.
- Use only a soft cloth to wash the vehicle. Do not spray pressurized water directly on the sensor or sensor cover.

(Continued)

(Continued)

- Be careful not to apply unnecessary force on the radar sensor or sensor cover. If the sensor is forcibly moved out of proper alignment, the FCA system may not operate correctly. In this case, a warning message may not be displayed. Have the vehicle inspected by an authorized HYUNDAI dealer.
- If the front bumper becomes damaged in the area around the radar sensor, the FCA system may not operate properly. We recommend that you have the vehicle inspected by authorized HYUNDAI dealer.
- Use only genuine parts to repair or replace a damaged sensor or sensor cover. Do not apply paint to the sensor cover.

## NOTICE

- NEVER install any accessories or stickers on the front windshield, nor tint the front windshield.
- NEVER locate any reflective objects (i.e. white paper, mirror) over the dashboard. Any light reflection may cause a malfunction of the system.
- Pay extreme caution to keep the camera out of water.
- NEVER disassemble the camera assembly, nor apply any impact on the camera assembly.
- Playing the vehicle audio system at high volume may offset the system warning sounds.

## **i** Information

We recommend that you have the system checked by an authorized HYUNDAI dealer when:

- The windshield glass is replaced.
- The radar sensor or cover gets damaged or replaced.

## Warning message and warning light



### Forward Collision Avoidance Assist (FCA) system disabled. Radar blocked

When the sensor cover is blocked with dirt, snow, or debris, the FCA system operation may stop temporarily. If this occurs, a warning message will appear on the LCD display.

Remove any dirt, snow, or debris and clean the radar sensor cover before operating the FCA system.

The system will operate normally when such dirt, snow or debris is removed.

The FCA may not properly operate in an area (e.g. open terrain), where any substances are not detected after turning ON the engine.

## **⚠** WARNING

**The FCA system may not activate according to the road conditions, inclement weather, driving conditions or traffic conditions.**



### Forward Collision-Avoidance Assist (FCA) system disabled. Camera obscured

When the sensor cover is blocked with dirt, snow, or debris, the FCA system operation may stop temporarily. If this occurs, a warning message will appear on the LCD display.

Remove any dirt, snow, or debris and clean the front camera before operating the FCA system.

The system will operate normally when such dirt, snow or debris is removed.

The FCA may not properly operate in an area (e.g. open terrain), where any substances are not detected after turning ON the engine.

## System malfunction



### Check Forward Collision Avoidance Assist system

- When the FCA is not working properly, the FCA warning light (🚨) will illuminate and the warning message will appear for a few seconds. After the message disappears, the master warning light (⚠️) will illuminate. In this case, we recommend that you have the vehicle inspected by an authorized HYUNDAI dealer.
- The FCA warning message may appear along with the illumination of the ESC (Electronic Stability Control) warning light.

## ⚠️ WARNING

- The FCA is only a supplemental system for the driver's convenience. The driver should hold the responsibility to control the vehicle operation. Do not solely depend on the FCA system. Rather, maintain a safe braking distance, and, if necessary, depress the brake pedal to reduce the driving speed.
- In certain instances and under certain driving conditions, the FCA system may activate unintentionally. This initial warning message appears on the LCD display with a warning chime.  
**Also, in certain instances the front radar sensor or camera recognition system may not detect the vehicle or pedestrian ahead. The FCA system may not activate and the warning message will not be displayed.**

(Continued)



**(Continued)**

- Even if there is any problem with the brake control function of the FCA system, the vehicle's basic braking performance will operate normally. However, brake control function for avoiding collision will not activate.
- If the vehicle in front stops suddenly, you may have less control of the brake system. Therefore, always keep a safe distance between your vehicle and the vehicle in front of you.
- The FCA system may activate during braking and the vehicle may stop suddenly shifting loose objects toward the passengers. Always keep loose objects secured.
- The FCA system may not activate if the driver applies the brake pedal to avoid a collision.

**(Continued)**

**(Continued)**

- The brake control may be insufficient, possibly causing a collision, if a vehicle in front abruptly stops. Always pay extreme caution.
- Occupants may get injured, if the vehicle abruptly stops by the activated FCA system. Pay extreme caution.
- The FCA system operates only to detect vehicle or pedestrian in front of the vehicle.

** WARNING**

- The FCA system does not operate when the vehicle is in reverse.
- The FCA system is not designed to detect other objects on the road such as animals.
- The FCA system does not detect vehicles in the opposite lane.
- The FCA system does not detect cross traffic vehicles that are approaching.
- The FCA system cannot detect the driver approaching the side view of a parked vehicle (for example on a dead end street.)

In these cases, you must maintain a safe braking distance, and if necessary, depress the brake pedal to reduce the driving speed in order to maintain a safe distance.

### Limitations of the system

The Forward Collision avoidance assist (FCA) system is designed to monitor the vehicle ahead or a pedestrian in the roadway through radar signals and camera recognition to warn the driver that a collision is imminent, and if necessary, apply emergency braking.

In certain situations, the radar sensor or the camera may not be able to detect the vehicle or pedestrian ahead. In these cases, the FCA system may not operate normally. The driver must pay careful attention in the following situations where the FCA operation may be limited.

### *Detecting vehicles*

The sensor may be limited when:

- The radar sensor or camera is blocked with a foreign object or debris
- The camera lens is contaminated due to tinted, filmed or coated windshield, damaged glass, or stuck of foreign matter (sticker, bug, etc.) on the glass
- Inclement weather such as heavy rain or snow obscures the field of view of the radar sensor or camera
- There is interference by electromagnetic waves
- There is severe irregular reflection from the radar sensor
- The radar/camera sensor recognition is limited
- The vehicle in front is too small to be detected (for example a motorcycle etc.)
- The vehicle in front is an oversize vehicle or trailer that is too big to be detected by the camera recognition system (for example a tractor trailer, etc.)
- The camera's field of view is not well illuminated (either too dark or too much reflection or too much backlight that obscures the field of view)
- The vehicle in front does not have their rear lights or their rear lights does not turned ON or their rear lights are located unusually.
- The outside brightness changes suddenly, for example when entering or exiting a tunnel
- When light coming from a street light or an oncoming vehicle is reflected on a wet road surface such as a puddle in the road
- The field of view in front is obstructed by sun glare or head light of oncoming vehicle.
- The windshield glass is fogged up; a clear view of the road is obstructed
- The vehicle in front is driving erratically
- The vehicle is on unpaved or uneven rough surfaces, or road with sudden gradient changes.

- The vehicle is driven near areas containing metal substances as a construction zone, railroad, etc.
- The vehicle drives inside a building, such as a basement parking lot
- The camera does not recognize the entire vehicle in front.
- The camera is damaged.
- The brightness outside is too low such as when the headlamps are not on at night or the vehicle is going through a tunnel.
- The shadow is on the road by a median strip, trees, etc.
- The vehicle drives through a toll-gate.
- The windshield glass is fogged up; a clear view of the road is obstructed.
- The rear part of the vehicle in front is not normally visible. (the vehicle turns in other direction or the vehicle is overturned.)
- The adverse road conditions cause excessive vehicle vibrations while driving
- The sensor recognition changes suddenly when passing over a speed bump
- The vehicle in front is moving vertically to the driving direction
- The vehicle in front is stopped vertically
- The vehicle in front is driving towards your vehicle or reversing
- You are on a roundabout and the vehicle in front circles

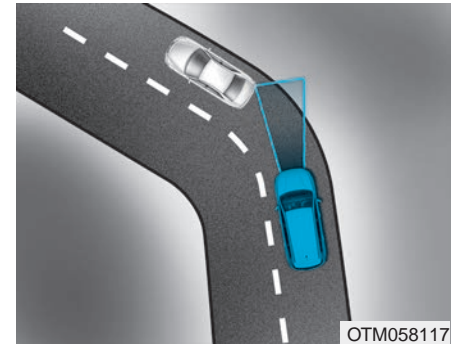

- Driving on a curve

The performance of the FCA system may be limited when driving on a curved road.

On curved roads, the other vehicle on the same lane is not recognized and the FCA system's performance may be degraded. This may result in unnecessary alarm or braking or no alarm or braking when necessary.

Also, in certain instances the front radar sensor or camera recognition system may not detect the vehicle traveling on a curved road.

In these cases, the driver must maintain a safe braking distance, and if necessary, depress the brake pedal to reduce your driving speed in order to maintain a safe distance.

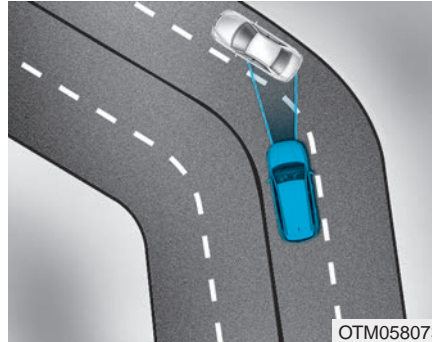

The FCA system may recognize a vehicle in the next lane when driving on a curved road.

In this case, the system may unnecessarily alarm the driver and apply the brake.

Always pay attention to road and driving conditions, while driving. If necessary, depress the brake pedal to reduce your driving speed in order to maintain a safe distance.

Also, when necessary depress the accelerator pedal to prevent the system from unnecessarily decelerating your vehicle.

Check to be sure that the road conditions permit safe operation of FCA.

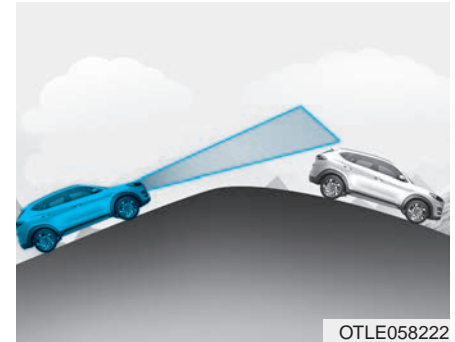

- Driving on a slope

The performance of the FCA decreases while driving upward or downward on a slope, not recognizing the vehicle in front in the same lane. It may unnecessarily produce the warning message and the warning alarm, or it may not produce the warning message and the warning alarm at all.

When the FCA suddenly recognizes the vehicle in front while passing over a slope, you may experience sharp deceleration.

Always keep your eyes forward while driving upward or downward on a slope, and, if necessary, depress the brake pedal to reduce your driving speed in order to maintain distance.

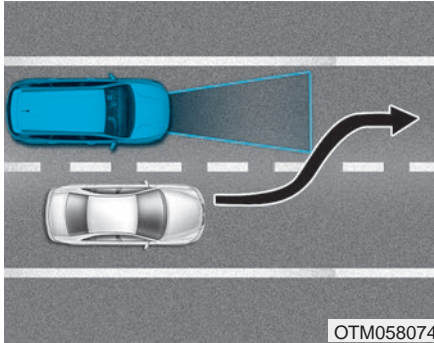

#### - Changing lanes

When a vehicle changes lanes in front of you, the FCA system may not immediately detect the vehicle, especially if the vehicle changes lanes abruptly. In this case, you must maintain a safe braking distance, and if necessary, depress the brake pedal to reduce your driving speed in order to maintain a safe distance.

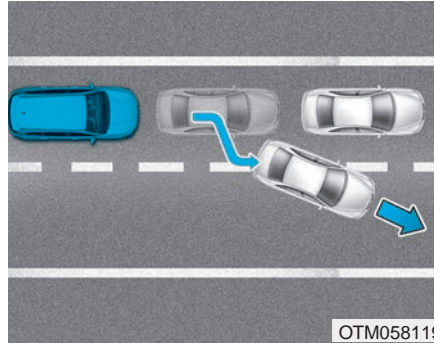

When driving in stop-and-go traffic, and a stopped vehicle in front of you merges out of the lane, the FCA system may not immediately detect the new vehicle that is now in front of you. In this case, you must maintain a safe braking distance, and if necessary, depress the brake pedal to reduce your driving speed in order to maintain a safe distance.

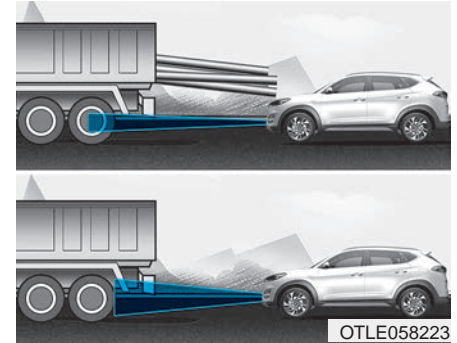

- Detecting the vehicle in front of you  
If the vehicle in front of you has cargo that extends rearward from the cab, or when the vehicle in front of you has higher ground clearance, additional special attention is required. The FCA system may not be able to detect the cargo extending from the vehicle. In these instances, you must maintain a safe braking distance from the rearmost object, and if necessary, depress the brake pedal to reduce your driving speed in order to maintain distance.

### ***Detecting pedestrians***

The sensor may be limited when:

- The pedestrian is not fully detected by the camera recognition system, for example, if the pedestrian is leaning over or is not fully walking upright
- The pedestrian is moving very quickly or appears abruptly in the camera detection area
- The pedestrian is wearing clothing that easily blends into the background, making it difficult to be detected by the camera recognition system
- The outside lighting is too bright (e.g. when driving in bright sunlight or in sun glare) or too dark (e.g. when driving on a dark rural road at night)
- It is difficult to detect and distinguish the pedestrian from other objects in the surroundings, for example, when there is a group of pedestrians, cyclists or a large crowd
- There is an item similar to a person's body structure
- The pedestrian is small
- The pedestrian has impaired mobility
- The sensor recognition is limited
- The radar sensor or camera is blocked with a foreign object or debris
- Inclement weather such as heavy rain or snow obscures the field of view of the radar sensor or camera
- When light coming from a street light or an oncoming vehicle is reflected on a wet road surface such as a puddle in the road
- The field of view in front is obstructed by sun glare
- The windshield glass is fogged up; a clear view of the road is obstructed
- The adverse road conditions cause excessive vehicle vibrations while driving
- When the pedestrian suddenly interrupts in front of the vehicle

### **WARNING**

- **Do not use the Forward Collision avoidance Assist (FCA) system when towing a vehicle. Application of the FCA system while towing may adversely affect the safety of your vehicle or the towing vehicle.**
- **Use extreme caution when the vehicle in front of you has cargo that extends rearward from the cab, or when the vehicle in front of you has higher ground clearance.**
- **The FCA system is designed to detect and monitor the vehicle ahead or detect a pedestrian in the roadway through radar signals and camera recognition. It is not designed to detect bicycles, motorcycles, or smaller wheeled objects such as luggage bags, shopping carts, or strollers.**

**(Continued)**

(Continued)

- **Never try to test the operation of the FCA system. Doing so may cause severe injury or death.**
- **If the front bumper, front glass, radar or camera have been replaced or repaired, we recommend that you have your vehicle inspected by an authorized HYUNDAI dealer.**

### **i** Information

In some instances, the FCA system may be cancelled when subjected to electromagnetic interference.

## FORWARD COLLISION-AVOIDANCE ASSIST (FCA) SYSTEM – SENSOR FUSION TYPE (FRONT RADAR + FRONT CAMERA) (IF EQUIPPED, FOR MIDDLE EAST)

The Forward Collision-Avoidance Assist (FCA) system is designed to help detect and monitor the vehicle ahead in the roadway through radar signals and camera recognition to warn the driver that a collision is imminent, and if necessary, apply emergency braking.

The FCA system detects the vehicle ahead in the roadway.

### WARNING

**Take the following precautions when using the Forward Collision-Avoidance Assist (FCA) system:**

- **This system is only a supplemental system and it is not intended to, nor does it replace the need for extreme care and attention of the driver. The sensing range and objects detectable by the sensors are limited. Pay attention to the road conditions at all times.**
- **NEVER drive too fast in accordance with the road conditions or while cornering.**
- **Always drive cautiously to prevent unexpected and sudden situations from occurring. FCA does not stop the vehicle completely and is not a collision avoidance system.**

### System setting and activation

#### System setting

- The driver can activate the FCA by placing the ignition switch to the ON position and by selecting: 'User Settings → Driver assistance → Forward Collision-Avoidance Assist (FCA)'

The FCA deactivates, when the driver cancels the system setting.



The warning light illuminates on the LCD display, when you cancel the FCA system. The driver can monitor the FCA ON/OFF status on the LCD display. Also, the warning light illuminates when the ESC (Electronic Stability Control) is turned off. If the warning light remains ON when the FCA is activated, we recommend that you have the system checked by an authorized HYUNDAI dealer.



- The driver can select the initial warning activation time on the LCD display.

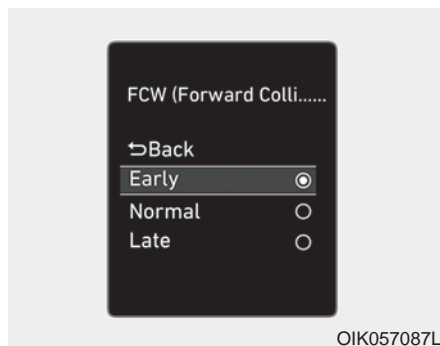

Go to the 'User Settings → Driver assistance → Forward Collision Warning → Early/Normal/Late'.

The options for the initial Forward Collision Warning includes the following:

- Early:

When this condition is selected, the initial Forward Collision Warning is activated earlier than normal. This setting maximizes the amount of distance between the vehicle ahead before the initial warning occurs.

Even though, 'Early' is selected if the front vehicle suddenly stops the initial warning activation time may not seem fast.

If you feel the warning activates too early, set the Forward Collision Warning to 'Normal'.

- Normal:

When this condition is selected, the initial Forward Collision Warning is activated normally. This setting allows for a nominal amount of distance between the vehicle ahead before the initial warning occurs.

- Late:

When this condition is selected, the initial Forward Collision Warning is activated later than normal. This setting reduces the amount of distance between the vehicle ahead before the initial warning occurs.

Select 'Late' when traffic is light and when driving speed is slow.

### **Prerequisite for activation**

The FCA gets ready to be activated, when the FCA is selected on the LCD display, and when the following prerequisites are satisfied.

- The ESC (Electronic Stability Control) is on.
- Vehicle speed is over 8 km/h (5 mph). (The FCA is only activated within a certain speed range.)
- The system detects a vehicle in front, which may collide with your vehicle. (The FCA may not be activated or may sound a warning alarm in accordance with the driving situation or vehicle condition.)

### **WARNING**

- **Completely stop the vehicle on a safe location before operating the switch on the steering wheel to activate/deactivate the FCA system.**
- **The FCA automatically activates upon placing the Engine Start/Stop button to the ON position. The driver can deactivate the FCA by canceling the system setting on the LCD display.**
- **The FCA automatically deactivates upon canceling the ESC (Electronic Stability Control). When the ESC is canceled, the FCA cannot be activated on the LCD display. The FCA warning light will illuminate which is normal.**

### **FCA warning message and system control**

The FCA produces warning messages and warning alarms in accordance with the collision risk levels, such as abrupt stopping of the vehicle in front, insufficient braking distance. Also, it controls the brakes in accordance with the collision risk levels.

The driver can select the initial warning activation time in the User Settings in the LCD display. The options for the initial Forward Collision Warning include Early, Normal or Late initial warning time.

### ***Collision Warning (First warning)***



This warning message appears on the LCD display with a warning chime. Additionally, some vehicle system intervention occurs by the engine management system to help decelerate the vehicle.

- Your vehicle speed may decelerate moderately.
- The FCA system limitedly controls the brakes to preemptively mitigate impact in a collision.

- It will operate if the vehicle speed is greater than approximately 8 km/h (5 mph) and less than or equal to 180 km/h (110 mph) on a forward vehicle. (Depending on the condition of the vehicle ahead and the environment surrounding it, the possible maximum operating speed may be reduced.)

### ***Emergency braking (Second warning)***



This warning message appears on the LCD display with a warning chime.

Additionally, some vehicle system intervention occurs by the engine management system to help decelerate the vehicle.

- The FCA system limitedly controls the brakes to preemptively mitigate impact in a collision. The brake control is maximized just before a collision.

- It will operate if the vehicle speed is greater than approximately 8 km/h (5 mph) and less than or equal to 80 km/h (50 mph) on a forward vehicle. (Depending on the condition of the vehicle ahead and the surrounding environment the possible maximum operating speed may be reduced.)

### ***Brake operation***

- In an urgent situation, the braking system enters into the ready status for prompt reaction against the driver's depressing the brake pedal.
- The FCA provides additional braking power for optimum braking performance, when the driver depresses the brake pedal.
- The braking control is automatically deactivated, when the driver sharply depresses the accelerator pedal, or when the driver abruptly operates the steering wheel.
- The FCA brake control is automatically canceled, when risk factors disappear.

### **CAUTION**

**The driver should always use extreme caution while operating the vehicle, whether or not there is a warning message or alarm from the FCA system.**

### **WARNING**

**The braking control cannot completely stop the vehicle nor avoid all collisions. The driver should hold the responsibility to safely drive and control the vehicle.**

### **WARNING**

**The FCA system logic operates within certain parameters, such as the distance from the vehicle ahead, the speed of the vehicle ahead, and the driver's vehicle speed. Certain conditions such as inclement weather and road conditions may affect the operation of the FCA system.**

### **WARNING**

**Never deliberately drive dangerously to activate the system.**

## FCA sensor

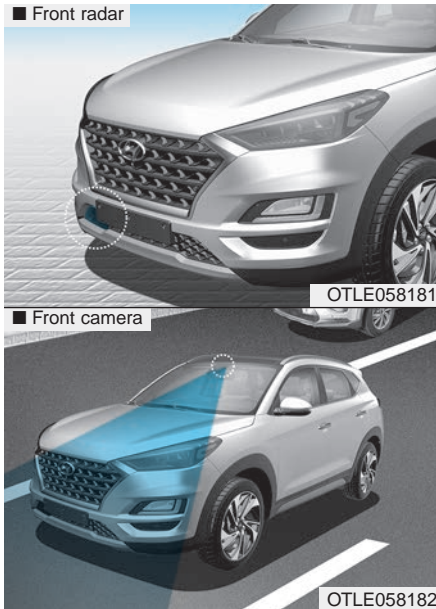

In order for the FCA system to operate properly, always make sure the sensor cover or sensor is clean and free of dirt, snow, and debris.

Dirt, snow, or foreign substances on the lens may adversely affect the sensing performance of the sensor.

### NOTICE

- Do not apply license plate molding or foreign objects such as a bumper sticker or a bumper guard near the radar sensor. Doing so may adversely affect the sensing performance of the radar.
- Always keep the radar sensor and cover clean and free of dirt and debris.
- Use only a soft cloth to wash the vehicle. Do not spray pressurized water directly on the sensor or sensor cover.

(Continued)

(Continued)

- Be careful not to apply unnecessary force on the radar sensor or sensor cover. If the sensor is forcibly moved out of proper alignment, the FCA system may not operate correctly. In this case, a warning message may not be displayed. Have the vehicle inspected by an authorized HYUNDAI dealer.
- If the front bumper becomes damaged in the area around the radar sensor, the FCA system may not operate properly. We recommend that you have the vehicle inspected by authorized HYUNDAI dealer.
- Use only genuine parts to repair or replace a damaged sensor or sensor cover. Do not apply paint to the sensor cover.

### NOTICE

- NEVER install any accessories or stickers on the front windshield, nor tint the front windshield.
- NEVER locate any reflective objects (i.e. white paper, mirror) over the dashboard. Any light reflection may cause a malfunction of the system.
- Pay extreme caution to keep the camera out of water.
- NEVER disassemble the camera assembly, nor apply any impact on the camera assembly.
- Playing the vehicle audio system at high volume may offset the system warning sounds.

### **i** Information

We recommend that you have the system checked by an authorized HYUNDAI dealer when:

- The windshield glass is replaced.
- The radar sensor or cover gets damaged or replaced.

### **Warning message and warning light**

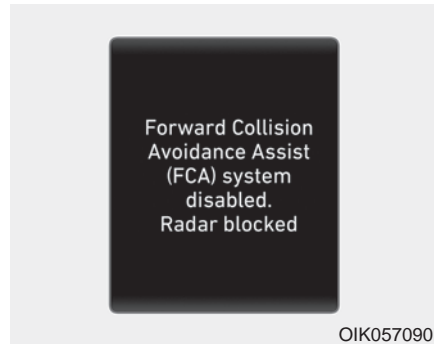

### **Forward Collision Avoidance Assist (FCA) system disabled. Radar blocked**

When the sensor cover is blocked with dirt, snow, or debris, the FCA system operation may stop temporarily. If this occurs, a warning message will appear on the LCD display.

Remove any dirt, snow, or debris and clean the radar sensor cover before operating the FCA system.

The system will operate normally when such dirt, snow or debris is removed.

The FCA may not properly operate in an area (e.g. open terrain), where any substances are not detected after turning ON the engine.

### **⚠ WARNING**

**The FCA system may not activate according to the road conditions, inclement weather, driving conditions or traffic conditions.**

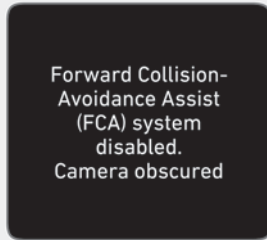

OTLE058183

### Forward Collision-Avoidance Assist (FCA) system disabled. Camera obscured

When the sensor cover is blocked with dirt, snow, or debris, the FCA system operation may stop temporarily. If this occurs, a warning message will appear on the LCD display.

Remove any dirt, snow, or debris and clean the front camera before operating the FCA system.

The system will operate normally when such dirt, snow or debris is removed.

The FCA may not properly operate in an area (e.g. open terrain), where any substances are not detected after turning ON the engine.

## System malfunction



OIK057091L

### Check Forward Collision Avoidance Assist system

- When the FCA is not working properly, the FCA warning light (🚨) will illuminate and the warning message will appear for a few seconds. After the message disappears, the master warning light (⚠️) will illuminate. In this case, we recommend that you have the vehicle inspected by an authorized HYUNDAI dealer.
- The FCA warning message may appear along with the illumination of the ESC (Electronic Stability Control) warning light.

## ⚠️ WARNING

- The FCA is only a supplemental system for the driver's convenience. The driver should hold the responsibility to control the vehicle operation. Do not solely depend on the FCA system. Rather, maintain a safe braking distance, and, if necessary, depress the brake pedal to reduce the driving speed.
- In certain instances and under certain driving conditions, the FCA system may activate unintentionally. This initial warning message appears on the LCD display with a warning chime.  
**Also, in certain instances the front radar sensor or camera recognition system may not detect the vehicle ahead. The FCA system may not activate and the warning message will not be displayed.**

(Continued)

(Continued)

- Even if there is any problem with the brake control function of the FCA system, the vehicle's basic braking performance will operate normally. However, brake control function for avoiding collision will not activate.
- If the vehicle in front stops suddenly, you may have less control of the brake system. Therefore, always keep a safe distance between your vehicle and the vehicle in front of you.
- The FCA system may activate during braking and the vehicle may stop suddenly shifting loose objects toward the passengers. Always keep loose objects secured.
- The FCA system may not activate if the driver applies the brake pedal to avoid a collision.

(Continued)

(Continued)

- The brake control may be insufficient, possibly causing a collision, if a vehicle in front abruptly stops. Always pay extreme caution.
- Occupants may get injured, if the vehicle abruptly stops by the activated FCA system. Pay extreme caution.
- The FCA system operates only to detect vehicles in front of the vehicle.

 **WARNING**

- The FCA system does not operate when the vehicle is in reverse.
- The FCA system is not designed to detect other objects on the road such as animals.
- The FCA system does not detect pedestrians in front of the vehicle.
- The FCA system does not detect vehicles in the opposite lane.
- The FCA system does not detect cross traffic vehicles that are approaching.
- The FCA system cannot detect the driver approaching the side view of a parked vehicle (for example on a dead end street.)

In these cases, you must maintain a safe braking distance, and if necessary, depress the brake pedal to reduce the driving speed in order to maintain a safe distance.



## Limitations of the system

The Forward Collision avoidance assist (FCA) system is designed to monitor the vehicle ahead in the roadway through radar signals and camera recognition to warn the driver that a collision is imminent, and if necessary, apply emergency braking.

In certain situations, the radar sensor or the camera may not be able to detect the vehicle ahead. In these cases, the FCA system may not operate normally. The driver must pay careful attention in the following situations where the FCA operation may be limited.

## Detecting vehicles

The sensor may be limited when:

- The radar sensor or camera is blocked with a foreign object or debris
- The camera lens is contaminated due to tinted, filmed or coated windshield, damaged glass, or stuck of foreign matter (sticker, bug, etc.) on the glass
- Inclement weather such as heavy rain or snow obscures the field of view of the radar sensor or camera
- There is interference by electromagnetic waves
- There is severe irregular reflection from the radar sensor
- The radar/camera sensor recognition is limited
- The vehicle in front is too small to be detected (for example a motor cycle or bicycle etc.)
- The vehicle in front is an oversize vehicle or trailer that is too big to be detected by the camera recognition system (for example a tractor trailer, etc.)
- The camera's field of view is not well illuminated (either too dark or too much reflection or too much backlight that obscures the field of view)
- The vehicle in front does not have their rear lights or their rear lights does not turned ON or their rear lights are located unusually.
- The outside brightness changes suddenly, for example when entering or exiting a tunnel
- When light coming from a street light or an oncoming vehicle is reflected on a wet road surface such as a puddle in the road
- The field of view in front is obstructed by sun glare or head light of oncoming vehicle.
- The windshield glass is fogged up; a clear view of the road is obstructed
- The vehicle in front is driving erratically
- The vehicle is on unpaved or uneven rough surfaces, or road with sudden gradient changes.

- The vehicle is driven near areas containing metal substances as a construction zone, railroad, etc.
- The vehicle drives inside a building, such as a basement parking lot
- The camera does not recognize the entire vehicle in front.
- The camera is damaged.
- The brightness outside is too low such as when the headlamps are not on at night or the vehicle is going through a tunnel.
- The shadow is on the road by a median strip, trees, etc.
- The vehicle drives through a toll-gate.
- The windshield glass is fogged up; a clear view of the road is obstructed.
- The rear part of the vehicle in front is not normally visible. (the vehicle turns in other direction or the vehicle is overturned.)
- The adverse road conditions cause excessive vehicle vibrations while driving
- The sensor recognition changes suddenly when passing over a speed bump
- The vehicle in front is moving vertically to the driving direction
- The vehicle in front is stopped vertically
- The vehicle in front is driving towards your vehicle or reversing
- You are on a roundabout and the vehicle in front circles

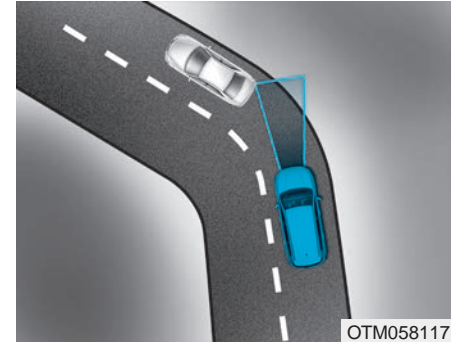

### - Driving on a curve

The performance of the FCA system may be limited when driving on a curved road.

On curved roads, the other vehicle on the same lane is not recognized and the FCA system's performance may be degraded. This may result in unnecessary alarm or braking or no alarm or braking when necessary.

Also, in certain instances the front radar sensor or camera recognition system may not detect the vehicle traveling on a curved road.

In these cases, the driver must maintain a safe braking distance, and if necessary, depress the brake pedal to reduce your driving speed in order to maintain a safe distance.

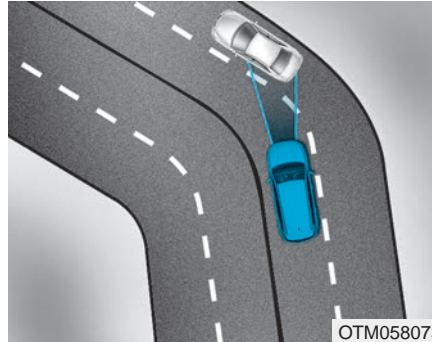

The FCA system may recognize a vehicle in the next lane when driving on a curved road.

In this case, the system may unnecessarily alarm the driver and apply the brake.

Always pay attention to road and driving conditions, while driving. If necessary, depress the brake pedal to reduce your driving speed in order to maintain a safe distance.

Also, when necessary depress the accelerator pedal to prevent the system from unnecessarily decelerating your vehicle.

Check to be sure that the road conditions permit safe operation of FCA.

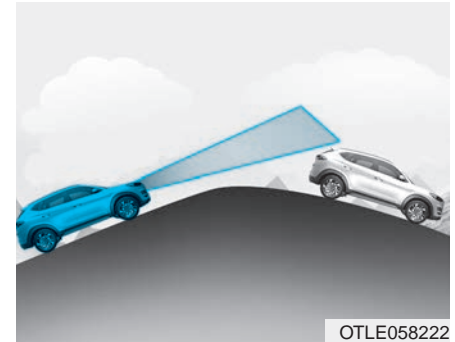

- Driving on a slope

The performance of the FCA decreases while driving upward or downward on a slope, not recognizing the vehicle in front in the same lane. It may unnecessarily produce the warning message and the warning alarm, or it may not produce the warning message and the warning alarm at all.

When the FCA suddenly recognizes the vehicle in front while passing over a slope, you may experience sharp deceleration.

Always keep your eyes forward while driving upward or downward on a slope, and, if necessary, depress the brake pedal to reduce your driving speed in order to maintain distance.

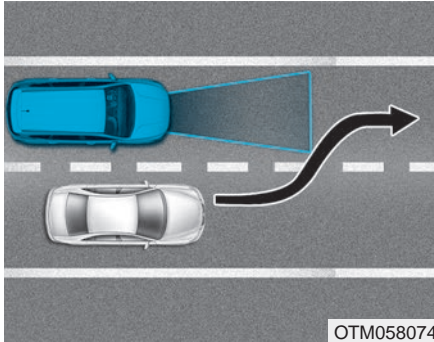

### - Changing lanes

When a vehicle changes lanes in front of you, the FCA system may not immediately detect the vehicle, especially if the vehicle changes lanes abruptly. In this case, you must maintain a safe braking distance, and if necessary, depress the brake pedal to reduce your driving speed in order to maintain a safe distance.

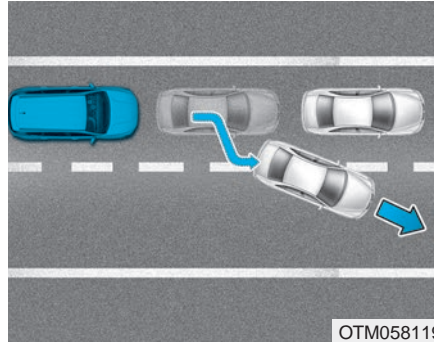

When driving in stop-and-go traffic, and a stopped vehicle in front of you merges out of the lane, the FCA system may not immediately detect the new vehicle that is now in front of you. In this case, you must maintain a safe braking distance, and if necessary, depress the brake pedal to reduce your driving speed in order to maintain a safe distance.

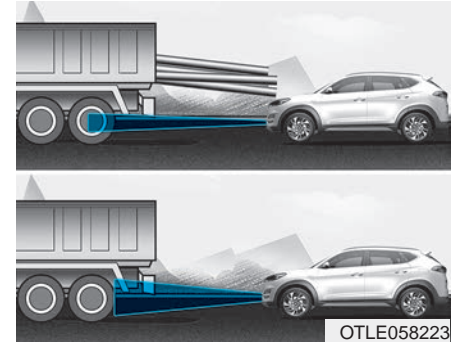

### - Detecting the vehicle in front of you

If the vehicle in front of you has cargo that extends rearward from the cab, or when the vehicle in front of you has higher ground clearance, additional special attention is required. The FCA system may not be able to detect the cargo extending from the vehicle. In these instances, you must maintain a safe braking distance from the rearmost object, and if necessary, depress the brake pedal to reduce your driving speed in order to maintain distance.

## WARNING

- Do not use the Forward Collision avoidance Assist (FCA) system when towing a vehicle. Application of the FCA system while towing may adversely affect the safety of your vehicle or the towing vehicle.
- Use extreme caution when the vehicle in front of you has cargo that extends rearward from the cab, or when the vehicle in front of you has higher ground clearance.
- The FCA system is designed to detect and monitor the vehicle ahead in the roadway through radar signals and camera recognition. It is not designed to detect bicycles, motorcycles, or smaller wheeled objects such as luggage bags, shopping carts, or strollers.

(Continued)

(Continued)

- Never try to test the operation of the FCA system. Doing so may cause severe injury or death.
- If the front bumper, front glass, radar or camera have been replaced or repaired, we recommend that you have your vehicle inspected by an authorized HYUNDAI dealer.

## Information

In some instances, the FCA system may be cancelled when subjected to electromagnetic interference.

## BLIND-SPOT COLLISION WARNING (BCW) SYSTEM (IF EQUIPPED)

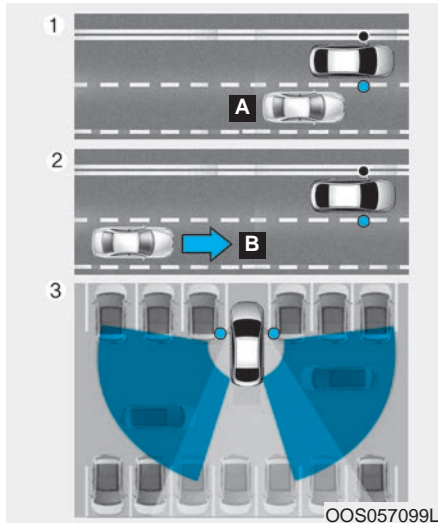

[A] : Blind spot area

[B] : Closing at high speed

The Blind-spot Collision Warning (BCW) system uses radar sensors in the rear bumper to monitor and warn the driver of an approaching vehicle in the driver's blind spot area.

The system monitors the rear area of the vehicle and provides information to the driver with an audible alert and an indicator on the outside rearview mirrors.

### (1) BCW : Blind spot area

The BCW range varies relative to vehicle speed. Note that if your vehicle is traveling much faster than the vehicles around you, the warning will not occur.

### (2) BCW : Closing at high speed

The BCW-Closing at high speed feature will alert you when a vehicle is approaching in an adjacent lane at a high rate of speed. If the driver activates the turn signal when the system detects an oncoming vehicle, the system sounds an audible alert. Distance from the approaching vehicle can be seen differently according to the relative speed.

### (3) RCCW (Rear Cross-Traffic Collision Warning)

The RCCW feature monitors approaching cross traffic from the left and right side of the vehicle when your vehicle is in reverse. The feature will operate when the vehicle is moving in reverse below about 10 km/h (6 mph). If oncoming cross traffic is detected a warning chime will sound.

Distance from the approaching vehicle can be seen differently according to the relative speed.

## ⚠ WARNING

- Always be aware of road conditions while driving and be alert for unexpected situations even though the Blind-Spot Collision Warning (BCW) system is operating.
- The Blind-spot Collision Warning (BCW) system is not a substitute for proper and safe driving. Always drive safely and use caution when changing lanes or backing up the vehicle. The Blind-spot Collision Warning (BCW) system may not detect every object alongside the vehicle.

## BCW (if equipped)

### Operating conditions

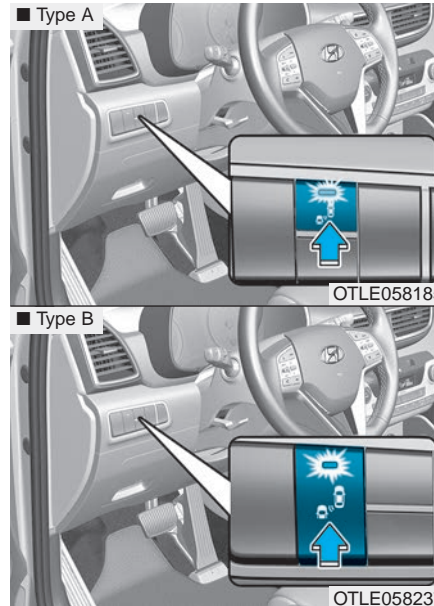

To operate:

Press the BCW switch with the Ignition switch in the ON position.

The indicator on the BCW switch will illuminate. When the vehicle speed exceeds 30 km/h (20 mph), the system will be activated.

To cancel:

Press the BCW switch again. The indicator on the switch will go off.

When the system is not used, turn the system off by turning off the switch.

### **i** Information

- If the vehicle is turned off then on again, the BCW system returns to the previous state.
- When the system is turned on, the warning light will illuminate for 3 seconds on the outside rearview mirror.

The function will activate when:

1. The function is on.
2. The vehicle speed is above approximately 30 km/h (20 mph).
3. An oncoming vehicle is detected in the blind spot area.



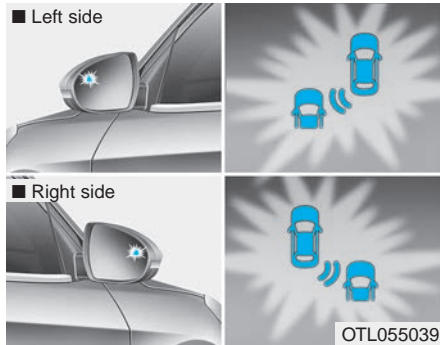

### First stage alert

If a vehicle is detected within the boundary of the system, a yellow warning light will illuminate on the outside rearview mirror.

Once the detected vehicle is no longer within the blind spot area, the warning will turn off depending on the driving conditions of the vehicle.

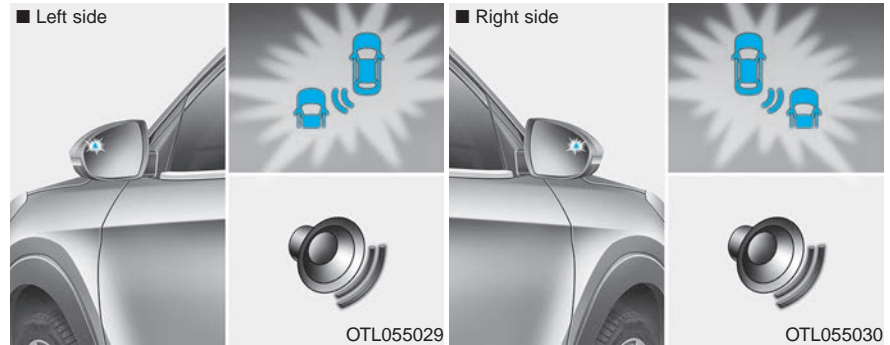

### Second stage alert

A warning chime to alert the driver will activate when:

1. A vehicle has been detected in the blind spot area by the radar system (the warning light will illuminate on the outside rearview mirror (i.e. in the first stage alert)) AND
2. The turn signal is applied (same side as where the vehicle is being detected).

When this alert is activated, the warning light on the outside rearview mirror will also blink.

If you turn off the turn signal indicator, the second stage alert (the warning chime and the blinking warning light on the outside rearview mirror) will be deactivated.



- The warning chime may be deactivated.

- To deactivate the warning chime:

Go to the "User Settings → Driver Assistance and deselect BCW sound (Blind-Spot Collision Warning)" on the LCD display.

- To activate the warning chime:

Go to the "User Settings → Driver Assistance and select BCW sound (Blind-Spot Collision Warning)" on the LCD display.

### **i** Information

The warning chime function helps alert the driver. Deactivate this function only when it is necessary.

Refer to "User settings mode" in chapter 3 for more details.

### **RCCW (Rear Cross-Traffic Collision Warning) (if equipped)**

The Rear Cross-Traffic Collision warning function monitors approaching cross traffic from the left and right side of the vehicle when your vehicle is in reverse.

#### **Operating conditions**

To operate:

Go to the 'User Settings → Driver Assistance and select RCCW (Rear Cross-Traffic Collision Warning)' on the LCD display.

The system will turn on and standby to activate. If you deactivate this function in the cluster, the system will stop.

Refer to "User settings mode" in chapter 3 for more details.

### **i** Information

If the vehicle is turned off then on again, the BCW system returns to the previous state.

The system will activate when vehicle speed is below 10 km/h (6 mph) and with the shift lever in R (Reverse).

The Rear Cross-Traffic Collision warning detecting range is approximately 0.5 m ~ 20 m (1 ft ~ 65 ft) in the direction of both lateral sides of the vehicle. An approaching vehicle will be detected if their vehicle speed is within 4 km/h ~ 36 km/h (2.5 ~ 22.5 mph).

Note that the detecting range may vary under certain conditions. As always, use caution and pay close attention to your surroundings when backing up your vehicle.

## Warning type

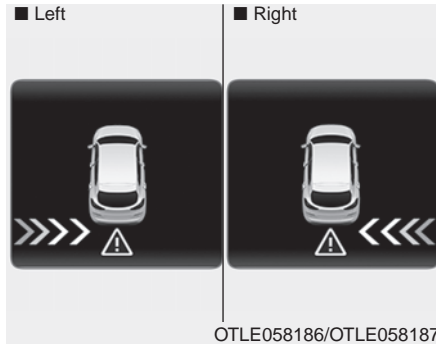

If the vehicle detected by the sensors approaches your vehicle, the warning chime will sound, the warning light on the outside rearview mirror will blink and a message will appear on the LCD display.

## **i** Information

- The warning chime will turn off when:
  - The detected vehicle moves out of the sensing area or
  - when the vehicle is right behind your vehicle or
  - when the vehicle is not approaching your vehicle or
  - when the other vehicle slows down.
- The system may not operate properly due to other factors or circumstances. Always pay attention to your surroundings.
- If the sensing area near the rear bumper is blocked by either a wall or barrier or by a parked vehicle, the system sensing area may be reduced.

## **!** WARNING

- When BCW is activated, the warning light on the outside rearview mirror will illuminate whenever a vehicle is detected at the rear side by the system.

To avoid accidents, do not focus only on the warning light and neglect to see the surrounding of the vehicle.

- Drive safely even though the vehicle is equipped with a Blind-spot Collision Warning (BCW) system and Rear Cross-Traffic Collision Warning (RCCW). Do not solely rely on the system but check your surrounding before changing lanes or backing the vehicle up.

The system may not alert the driver in some conditions so always check your surroundings while driving.

(Continued)

(Continued)

- The Blind-spot Collision Warning (BCW) system and Rear Cross-Traffic Collision warning (RCCW) are not a substitute for proper and safe driving practices. Always drive safely and use caution when changing lanes or backing up your vehicle. The Blind-spot Collision Warning (BCW) system may not detect every object alongside the vehicle.

#### NOTICE

- The system may not work properly when the bumper has been damaged, or if the rear bumper has been replaced or repaired.
- The sensing range differs somewhat according to the width of the road. When the road is narrow, the system may detect other vehicles in the next lane OR when the road is wide, the system may not detect other vehicles in the next lane.
- The system may turn off due to strong electromagnetic waves.

### Detecting sensor



The sensors are located inside the rear bumper.

Always keep the rear bumper clean for proper operation of the system.

### Warning message



#### Blind-Spot Collision Warning (BCW) system disabled. Radar blocked

- This warning message may appear when :
  - One or both of the sensors on the rear bumper is blocked by dirt or snow or a foreign object.
  - Driving in rural areas where the BCW sensor does not detect another vehicle for an extended period of time.
  - When there is inclement weather such as heavy snow or rain.

- A trailer or carrier is installed. To use the BCW system, remove the trailer or carrier from your vehicle.

If any of these conditions occur, the light on the BCW switch and the system will turn off automatically.

When the BCW canceled warning message is displayed in the cluster, check to make sure that the rear bumper is free from any dirt or snow in the areas where the sensor is located. Remove any dirt, snow, or foreign material that could interfere with the radar sensors.

After any dirt or debris is removed, the BCW system should operate normally after about 10 minutes of driving the vehicle.

If the system still does not operate normally have your vehicle inspected by an authorized HYUNDAI dealer.

### **i** Information

**Turn off the system by pressing the BCW switch and deselecting Rear Cross-Traffic Collision warning (RCCW) from the User Settings mode on the cluster, when using a trailer or carrier behind your vehicle.**

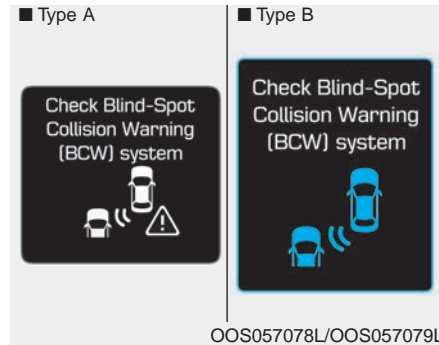

### Check Blind-Spot Collision Warning (BCW) system

If there is a problem with the BCW system, a warning message will appear and the light on the switch will turn off. The system will turn off automatically. We recommend that you have your vehicle inspected by an authorized HYUNDAI dealer.

### Limitations of the system

The driver must be cautious in the below situations, because the system may not detect other vehicles or objects in certain circumstances.

- When a trailer or carrier is installed.
- The vehicle drives in inclement weather such as heavy rain or snow.
- The sensor is polluted with rain, snow, mud, etc.
- The rear bumper where the sensor is located is covered with a foreign object such as a bumper sticker, a bumper guard, a bike rack, etc.
- The rear bumper is damaged, or the sensor is out of the original default position.
- The vehicle height gets lower or higher due to heavy loading in the luggage compartment, abnormal tire pressure, etc.
- When the temperature near the rear bumper area is high or low.

- When the sensors are blocked by other vehicles, walls or parking-lot pillars.
- The vehicle drives on a curved road or through a tollgate.
- The vehicle is driven near areas containing metal substances such as a construction zone, railroad, etc.
- There is a fixed object near the vehicle, such as a guardrail, person, animal, etc.
- While going down or up a steep road where the height of the lane is different.
- When driving through a narrow road with many trees or bushes.
- When driving on wet surfaces.
- When driving through a large area with few vehicles or structures around, such as a desert, rural area, etc.
- A big vehicle is near such as a bus or truck.
- When other vehicles are close to your vehicle.
- When the other vehicle approaches very close.
- When the detected vehicle also moves back, as your vehicle drives back.
- While changing lanes.
- If the vehicle has started at the same time as the vehicle next to you and has accelerated.
- When the other vehicle passes at a very fast speed.
- When the vehicle in the next lane moves two lanes away from you OR when the vehicle two lanes away moves to the next lane to you.
- The vehicle is turning left or right at a crossroads.
- A motorcycle or bicycle is near.
- A flat trailer is near.
- If there are small objects in the detecting area such as a shopping cart, a baby stroller or pedestrian.
- If there is a low height vehicle such as a sports car.

**The BCW indicator on the outer side view mirror may not illuminate properly when:**

- The outside rearview mirror housing is damaged.
- The mirror is covered with dirt, snow, or debris.
- The window is covered with dirt, snow, or debris.
- The window is tinted.

## LANE KEEPING ASSIST (LKA) SYSTEM (FOR EUROPE) (IF EQUIPPED)

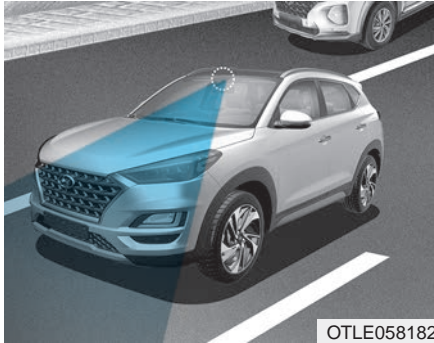

The Lane Keeping Assist (LKA) system with a camera at the front windshield, helps detect lane markers and road edge on the road, and assists the driver's steering to help keep the vehicle between lanes.

When the system detects the vehicle straying from its lane (or road), it alerts the driver with a visual and audible warning, while applying a counter-steering torque, trying to prevent the vehicle from moving out of its lane (or road).

### WARNING

The Lane Keeping Assist (LKA) system is not a substitute for safe driving practices, but a convenience function. It is the responsibility of the driver to always be aware of the surrounding and steer the vehicle.

### WARNING

Take the following precautions when using the Lane Keeping Assist (LKA) system:

- Do not steer the steering wheel suddenly when the steering wheel is being assisted by the system.
- LKA system helps to prevent the driver from moving out of the lane (or road) unintentionally by assisting the driver's steering. However, the driver should not solely rely on the system but always pay attention on the steering wheel to stay in the lane.

(Continued)

(Continued)

- The operation of the LKA system can be canceled or not work properly according to road condition and surroundings. Always be cautious when driving.
- Do not disassemble the LKA system camera temporarily to tint the window or attach any types of coatings and accessories. If you disassemble the camera and assemble it again, we recommend that you take your vehicle to an authorized HYUNDAI dealer and have the system checked for calibration.
- When you replace the windshield glass, LKA system camera or related parts of the steering wheel, we recommend that you take your vehicle to an authorized HYUNDAI dealer and have the system checked for calibration.

(Continued)

(Continued)

- The system detects lane markers (or road edge) and controls the steering wheel by a camera, therefore, if the lane markers (or road edge) are hard to detect, the system may not work properly. Please refer to "Limitations of the system".
- Do not remove or damage the related parts of LKA system.
- You may not hear a warning sound of LKA system because of excessive audio sound.
- Do not place objects on the dashboard that reflects light such as mirrors, white paper, etc. The system may malfunction if the sunlight is reflected.

(Continued)

(Continued)

- Always have your hands on the steering wheel while the LKA system is activated. If you continue to drive with your hands off the steering wheel after the "Keep hands on steering wheel" warning message appears, the system will stop control the steering wheel.
- The steering wheel is not continuously controlled so if the vehicle speed is at a higher rate when leaving a lane (or road edge) the vehicle may not be controlled by the system. The driver must always follow the speed limit when using the system.
- If you attach objects to the steering wheel, the system may not assist steering or the hands off alarm may not work properly.
- When you tow a trailer, make sure that you turn off the LKA system.

## LKA operation

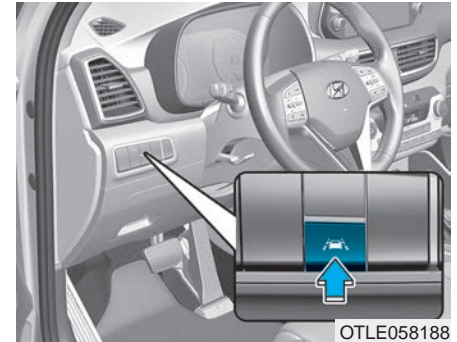

To activate/deactivate the LKA system:

With the ignition switch in the ON position, press the LKA system button located on the instrument panel on the left hand side of the steering wheel. (Right hand side of the steering wheel for RHD vehicles.)

The indicator in the cluster display will initially illuminate white. This indicates the LKA system is in the READY but NOT ENABLED state.



Note that the vehicle speed must be at least approximately 60 km/h (37 mph) to ENABLE the

LKA system. The indicator in the cluster display will illuminate green.

The color of indicator will change depending on the condition of LKA system.

- White : Sensor does not detect lane markers or vehicle speed is under 60 km/h (37 mph).
- Green : Sensor detects lane markers and the system is able to control vehicle steering.

### **i** Information

The LKA automatically activates upon placing the Engine Start/Stop button to the ON position. The switch indicator will be on and the indicator in the cluster display will initially illuminate white. The driver can deactivate the LKA by pushing LKA switch located on the instrument panel on the left hand side of the steering wheel or LDW selecting from the User Settings Mode on the LCD display.

### **LKA activation**

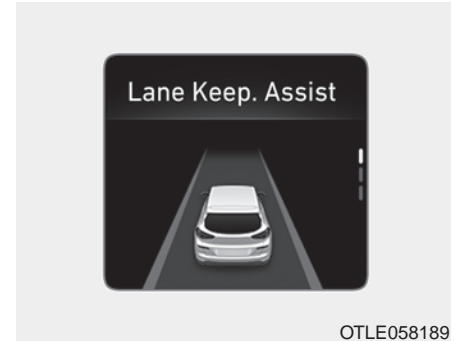

- To see the LKA system screen on the LCD display in the cluster, select ASSIST mode (A). For more details, refer to "LCD Display Modes" in chapter 3.
- After LKA is activated, if lane marker (or road edge) is detected, vehicle speed is over 60 kph (37 mph) and all the activation conditions are satisfied, a green LKA indicator will change to green and the steering wheel will be controlled.



## **⚠ WARNING**

The Lane Keeping Assist (LKA) system is a system to prevent the driver from leaving the lane. However, the driver should not solely rely on the system but always check the road conditions when driving.

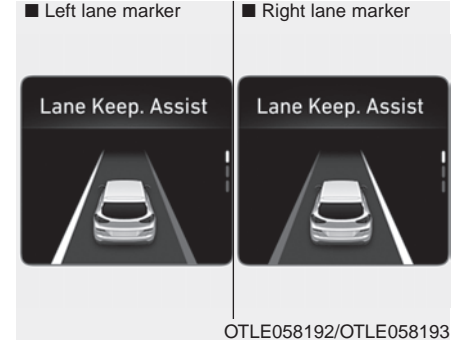

- If vehicle speed is over 60 km/h (37 mph) and the system detects lane markers, the color changes from gray to white.
- If the system detects the left lane marker, the left lane marker color will change from gray to white.
- If the system detects the right lane marker, the right lane marker color will change from gray to white.
- If your vehicle speed exceeds 60 km/h (37 mph) and the LKA system button is ON, the system is enabled. If your vehicle departs from the projected lane in front of you, the LKA system operates as follows:

A visual warning appears on the cluster LCD display. Either the left lane marker or the right lane marker in the cluster LCD display will blink depending on which direction the vehicle is veering.

### ■ Lane Keeping Assist is enabled



OTLE058191

- The LKA system will control the vehicle's steering to prevent the vehicle from crossing the lane marker in below conditions.
  - Vehicle speed is over 60 km/h (37 mph)
  - The system detects lanes
  - When driving, the vehicle is located between both lanes normally.
  - The steering wheel is not turned suddenly.

When lanes are detected and all the conditions to activate the LKA system are satisfied, a LKA system indicator light will change from white to green. This indicates that the LKA system is in the ENABLED state and the steering wheel will be able to be controlled.



OTLE058194

### **Keep hands on steering wheel**

If the driver takes their hands off the steering wheel for several seconds while the LKA system is activated, the system will warn the driver.

### ***i* Information**

**If the steering wheel is held very lightly the message may still appear because the LKA system may not recognize that the driver has their hands on the wheel.**

## **⚠ WARNING**

The warning message may appear late according to road conditions. Therefore, always have your hands on the steering wheel while driving.



Driver's hands  
not detected.  
LKA system is  
disabled  
temporarily

OTLE058195

### **Driver's hands not detected. LKA system is disabled temporarily**

If the driver still does not have their hands on the steering wheel after the message "Keep hands on steering wheel", the system will not control the steering wheel and warn the driver only when the driver crosses the lane marker.

However, if the driver has their hands on the steering wheel again, the system will start controlling the steering wheel.

## **⚠ WARNING**

- The driver is responsible for accurate steering.
- Turn off the system and drive the vehicle in following situations.
  - In bad weather
  - In bad road condition
  - When the steering wheel needs to be controlled by the driver frequently.

### ***i* Information**

- Even though the steering is assisted by the system, the driver may control the steering wheel.
- The steering wheel may feel heavier when the steering wheel is assisted by the system than when it is not.

## Warning light and message

### Check LKA system



If there is a problem with the system a message will appear for a few seconds. If the problem continues the LKA system failure indicator will illuminate.

### LKA system failure indicator



The LKA system failure indicator (yellow) will illuminate if the LKA system is not working properly. We recommend that the system be checked by an authorized HYUNDAI dealer.

#### When there is a problem with the system do one of the following:

- Turn the system on after turning the engine off and on again.
- Check if the ignition switch is in the ON position.
- Check if the system is affected by the weather. (e.g. fog, heavy rain, etc.)
- Check if there is foreign matter on the camera lens.

If the problem is not solved, we recommend that the system be checked by an authorized HYUNDAI dealer.

The LKA system will not be in the **ENABLED** state and the steering wheel will not be assisted when:

- The turn signal is turned on before changing a lane. If you change lanes without the turn signal on, the steering wheel might be controlled.
- The vehicle is not driven in the middle of the lane when the system is turned on or right after changing a lane.
- ESC (Electronic Stability Control) or VSM (Vehicle Stability Management) is activated.
- The vehicle is driven on a sharp curve.
- Vehicle speed is below 55 km/h (34 mph) and over 200 km/h (125 mph).
- The vehicle makes sharp lane changes.
- The steering will not be assisted when you cross the lane fast.
- The steering will not be assisted when you brake suddenly.
- The vehicle brakes suddenly.

- The steering will not be assisted when the lane (or road width) is very wide or narrow.
- There are more than two lane markers such as a construction area.
- The vehicle is driven on a steep incline.
- The steering wheel is turned suddenly.

### Limitations of the System

The LKA system may operate prematurely even if the vehicle does not depart from the intended lane, OR, the LKA system may not assist your steering or warn you if the vehicle leaves the intended lane under the following circumstances:

#### When the lane and road conditions are poor

- It is difficult to distinguish the lane marker from the road surface or the lane marker is faded or not clearly marked.

- It is difficult to distinguish the color of the lane marker from the road.
- There are markings on the road surface that look like a lane marker that is inadvertently being detected by the camera.
- The lane marker is indistinct or damaged.
- The lane marker is merged or divided. (e.g. tollgate)
- The lane number increases or decreases or the lane marker are crossing complicatedly.
- There are more than two lane markers on the road in front of you.
- The lane marker is very thick or thin.
- The lane (or road width) is very wide or narrow.
- The lane marker ahead are not visible due to rain, snow, water on the road, damaged or stained road surface, or other factors.
- The shadow is on the lane marker by a median strip, trees, etc.

- The lanes are incomplete or the area is in a construction zone.
- There are crosswalk signs or other symbols on the road.
- The lane marker in a tunnel is stained with oil, etc.
- The lane suddenly disappears such as at the intersection.

#### When external condition is intervened

- The brightness outside changes suddenly such as when entering or exiting a tunnel, or when passing under a bridge.
- The brightness outside is too low such as when the headlamps are not on at night or the vehicle is going through a tunnel.
- There is a boundary structure in the roadway such as a concrete barrier, guardrail and reflector post that is inadvertently being detected by the camera.
- When light coming from a street light or an oncoming vehicle is reflected on a wet road surface such as a puddle in the road.

- The field of view in front is obstructed by sun glare.
- There is not enough distance between you and the vehicle in front to be able to detect the lane marker or the vehicle ahead is driving on the lane marker.
- Road surface is not evenness.
- Driving on a steep grade, over a hill, or when driving on a curved road.
- The adverse road conditions cause excessive vehicle vibrations while driving.
- The surrounding of the inside rear view mirror temperature is high due to direct sunlight, etc.

### **When front visibility is poor**

- The windshield or the LKA camera lens is blocked with dirt or debris.
- The windshield glass is fogged up; a clear view of the road is obstructed.
- Placing objects on the dashboard, etc.
- The sensor cannot detect the lane because of fog, heavy rain or snow.

### **LKA system function change**

The driver can change LKA to the Lane Departure Warning (LDW) system or change the LKA system mode from the LCD display. Go to the "User Settings → Driver Assistance → Lane Safety → Lane Keeping Assist (LKA)/Lane Departure Warning (LDW)".

The system is automatically set to Lane Keeping Assist(LKA) if a function is not selected.

### ***Lane Keeping Assist (LKA)***

This mode guides the driver to help keep the vehicle within the lanes. It rarely controls the steering wheel, when the vehicle drives well inside the lanes. However, it starts to control the steering wheel, when the vehicle is about to deviate out of the lane.

### ***Lane Departure Warning (LDW)***

LDW system alerts the driver with a visual warning and a warning alarm when the system detects the vehicle departing the lane. The steering wheel will not be controlled.

## LANE KEEPING ASSIST (LKA) SYSTEM (EXCEPT EUROPE) (IF EQUIPPED)

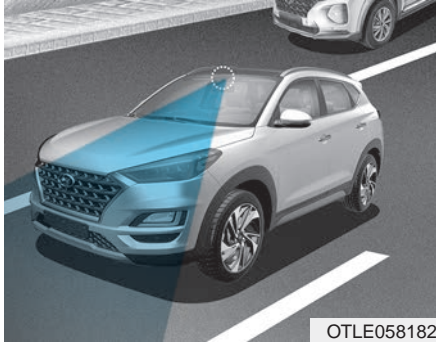

OTLE058182

The Lane Keeping Assist (LKA) system with a camera at the front windshield, helps detect lane markers on the road, and assists the driver's steering to help keep the vehicle between lanes.

When the system detects the vehicle straying from its lane, it alerts the driver with a visual and audible warning, while applying a counter-steering torque, trying to prevent the vehicle from moving out of its lane.

### WARNING

The Lane Keeping Assist (LKA) system is not a substitute for safe driving practices, but a convenience function. It is the responsibility of the driver to always be aware of the surrounding and steer the vehicle.

### WARNING

Take the following precautions when using the Lane Keeping Assist (LKA) system:

- Do not steer the steering wheel suddenly when the steering wheel is being assisted by the system.
- LKA system helps to prevent the driver from moving out of the lane unintentionally by assisting the driver's steering. However, the driver should not solely rely on the system but always pay attention on the steering wheel to stay in the lane.

(Continued)

(Continued)

- The operation of the LKA system can be canceled or not work properly according to road condition and surroundings. Always be cautious when driving.
- Do not disassemble the LKA system camera temporarily to tint the window or attach any types of coatings and accessories. If you disassemble the camera and assemble it again, we recommend that you take your vehicle to an authorized HYUNDAI dealer and have the system checked for calibration.
- When you replace the windshield glass, LKA system camera or related parts of the steering wheel, we recommend that you take your vehicle to an authorized HYUNDAI dealer and have the system checked for calibration.

(Continued)

### (Continued)

- The system detects lane markers and controls the steering wheel by a camera, therefore, if the lane markers are hard to detect, the system may not work properly. Please refer to "Limitations of the system".
- Do not remove or damage the related parts of LKA system.
- You may not hear a warning sound of LKA system because of excessive audio sound.
- Do not place objects on the dashboard that reflects light such as mirrors, white paper, etc. The system may malfunction if the sunlight is reflected.

(Continued)

### (Continued)

- Always have your hands on the steering wheel while the LKA system is activated. If you continue to drive with your hands off the steering wheel after the "Keep hands on steering wheel" warning message appears. If "Active LKA" is selected on the User Setting Mode, the system will stop control the steering wheel.
- The steering wheel is not continuously controlled so if the vehicle speed is at a higher rate when leaving a lane the vehicle may not be controlled by the system. The driver must always follow the speed limit when using the system.
- If you attach objects to the steering wheel, the system may not assist steering or the hands off alarm may not work properly.
- When you tow a trailer, make sure that you turn off the LKA system.

## LKA operation

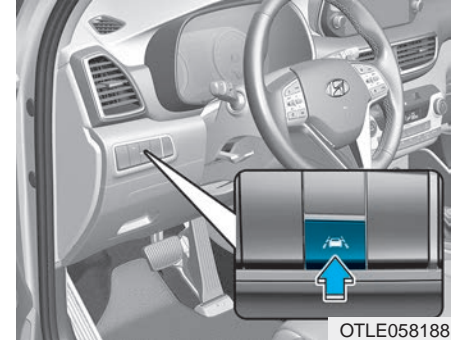

To activate/deactivate the LKA system:

With the ignition switch in the ON position, press the LKA system button located on the instrument panel on the left hand side of the steering wheel. (Right hand side of the steering wheel for RHD vehicles.)

The indicator in the cluster display will initially illuminate white. This indicates the LKA system is in the READY but NOT ENABLED state.





Note that the vehicle speed must be at least approximately 60 km/h (37 mph) to ENABLE the

LKA system. The indicator in the cluster display will illuminate green.

The color of indicator will change depending on the condition of LKA system.

- White : Sensor does not detect lane markers or vehicle speed is under 60 km/h (37 mph).
- Green : Sensor detects lane markers and the system is able to control vehicle steering.

### **i** Information - (For Middle East)

**If the indicator (white) is activated from the previous ignition cycle, the system will turn ON without any additional control. If you press the LKA button again, the indicator on the cluster goes off.**

### **LKA activation**

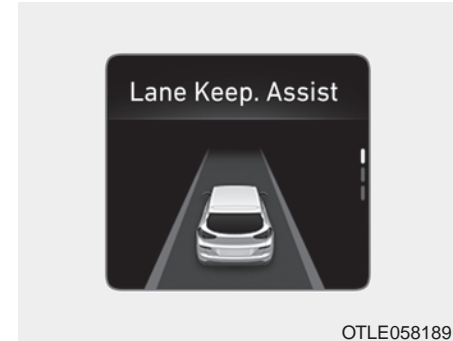

- To see the LKA system screen on the LCD display in the cluster, select ASSIST mode (A). For more details, refer to "LCD Display Modes" in chapter 3.
- After LKA is activated, if lane marker is detected, vehicle speed is over 60 km/h (37 mph) and all the activation conditions are satisfied, a green LKA indicator will change to green and the steering wheel will be controlled.

**⚠ WARNING**

The Lane Keeping Assist (LKA) system is a system to prevent the driver from leaving the lane. However, the driver should not solely rely on the system but always check the road conditions when driving.

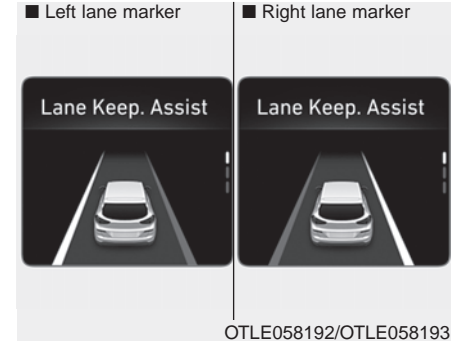
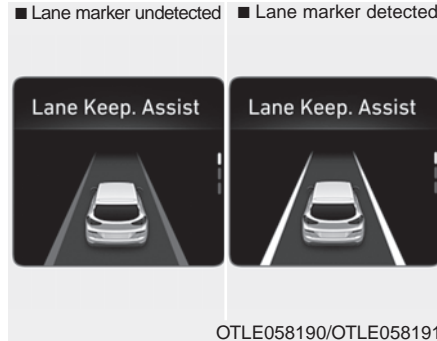

- If vehicle speed is over 60 km/h (37 mph) and the system detects lane markers, the color changes from gray to white.
- If the system detects the left lane marker, the left lane marker color will change from gray to white.
- If the system detects the right lane marker, the right lane marker color will change from gray to white.
- If your vehicle speed exceeds 60 km/h (37 mph) and the LKA system button is ON, the system is enabled. If your vehicle departs from the projected lane in front of you, the LKA system operates as follows:

A visual warning appears on the cluster LCD display. Either the left lane marker or the right lane marker in the cluster LCD display will blink depending on which direction the vehicle is veering.

■ Lane Keeping Assist is enabled



OTLE058191

- The LKA system will control the vehicle's steering to prevent the vehicle from crossing the lane marker in below conditions.
  - Vehicle speed is over 60 km/h (37 mph)
  - The system detects both lanes (For Middle East)
  - When driving, the vehicle is located between both lanes normally. (For Middle East)
  - The steering wheel is not turned suddenly.

When both lane markers are detected and all the conditions to activate the LKA system are satisfied, a LKA system indicator light will change from white to green. This indicates that the LKA system is in the ENABLED state and the steering wheel will be able to be controlled. (For Middle East)



OTLE058194

### Keep hands on steering wheel

If the driver takes their hands off the steering wheel for several seconds while the LKA system is activated, the system will warn the driver.

### **i** Information

**If the steering wheel is held very lightly the message may still appear because the LKA system may not recognize that the driver has their hands on the wheel.**

**⚠ WARNING**

The warning message may appear late according to road conditions. Therefore, always have your hands on the steering wheel while driving.



Driver's hands  
not detected.  
LKA system is  
disabled  
temporarily

OTLE058195

**Driver's hands not detected.  
LKA system is disabled temporarily  
(For Active LKA)**

If the driver still does not have their hands on the steering wheel after the message "Keep hands on steering wheel", the system will not control the steering wheel and warn the driver only when the driver crosses the lane markers.

However, if the driver has their hands on the steering wheel again, the system will start controlling the steering wheel.

**⚠ WARNING**

- The driver is responsible for accurate steering.
- Turn off the system and drive the vehicle in following situations.
  - In bad weather
  - In bad road condition
  - When the steering wheel needs to be controlled by the driver frequently.

***i* Information**

- Even though the steering is assisted by the system, the driver may control the steering wheel.
- The steering wheel may feel heavier when the steering wheel is assisted by the system than when it is not.

## Warning light and message

### Check LKA system

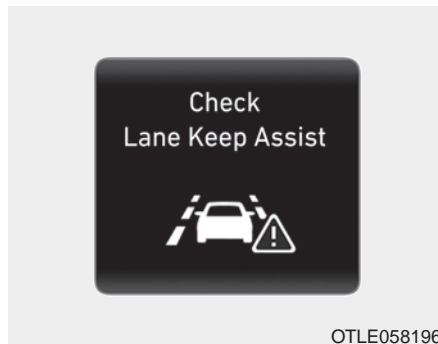

If there is a problem with the system a message will appear for a few seconds. If the problem continues the LKA system failure indicator will illuminate.

### LKA system failure indicator



The LKA system failure indicator (yellow) will illuminate if the LKA system is not working properly. We recommend that the system be checked by an authorized HYUNDAI dealer.

#### When there is a problem with the system do one of the following:

- Turn the system on after turning the engine off and on again.
- Check if the ignition switch is in the ON position.
- Check if the system is affected by the weather. (e.g. fog, heavy rain, etc.)
- Check if there is foreign matter on the camera lens.

If the problem is not solved, we recommend that the system be checked by an authorized HYUNDAI dealer.

The LKA system will not be in the **ENABLED** state and the steering wheel will not be assisted when:

- The turn signal is turned on before changing a lane. If you change lanes without the turn signal on, the steering wheel might be controlled.
- The vehicle is not driven in the middle of the lane when the system is turned on or right after changing a lane.
- ESC (Electronic Stability Control) or VSM (Vehicle Stability Management) is activated.
- The vehicle is driven on a sharp curve.
- Vehicle speed is below 55 km/h (34 mph) and over 180 km/h (112 mph).
- The vehicle makes sharp lane changes.
- The steering will not be assisted when you cross the lane fast.
- The steering will not be assisted when you brake suddenly.
- The vehicle brakes suddenly.
- Only one lane marker is detected.

- The steering will not be assisted when the lane (or road width) is very wide or narrow.
- There are more than two lane markers such as a construction area.
- The vehicle is driven on a steep incline.
- The steering wheel is turned suddenly.

### Limitations of the System

The LKA system may operate prematurely even if the vehicle does not depart from the intended lane, OR, the LKA system may not assist your steering or warn you if the vehicle leaves the intended lane under the following circumstances:

#### **When the lane and road conditions are poor**

- It is difficult to distinguish the lane marking from the road surface or the lane marking is faded or not clearly marked.
- It is difficult to distinguish the color of the lane marker from the road.
- There are markings on the road surface that look like a lane marker that is inadvertently being detected by the camera.
- The lane marker is indistinct or damaged.
- The lane marker is merged or divided. (e.g. tollgate)
- The lane number increases or decreases or the lane marker are crossing complicatedly.

- There are more than two lane markers on the road in front of you.
- The lane marker is very thick or thin.
- The lane (or road width) is very wide or narrow.
- The lanes ahead are not visible due to rain, snow, water on the road, damaged or stained road surface, or other factors.
- The shadow is on the lane marker by a median strip, trees, etc.
- The lanes are incomplete or the area is in a construction zone.
- There are crosswalk signs or other symbols on the road.
- The lane marker in a tunnel is stained with oil, etc.
- The lane suddenly disappears such as at the intersection.

### **When external condition is intervened**

- The brightness outside changes suddenly such as when entering or exiting a tunnel, or when passing under a bridge.
- The brightness outside is too low such as when the headlamps are not on at night or the vehicle is going through a tunnel.
- There is a boundary structure in the roadway such as a concrete barrier, guardrail and reflector post that is inadvertently being detected by the camera.
- When light coming from a street light or an oncoming vehicle is reflected on a wet road surface such as a puddle in the road.
- The field of view in front is obstructed by sun glare.

- There is not enough distance between you and the vehicle in front to be able to detect the lane marker or the vehicle ahead is driving on the lane marker.
- Road surface is not evenness.
- Driving on a steep grade, over a hill, or when driving on a curved road.
- The adverse road conditions cause excessive vehicle vibrations while driving.
- The surrounding of the inside rear view mirror temperature is high due to direct sunlight, etc.

### **When front visibility is poor**

- The windshield or the LKA camera lens is blocked with dirt or debris.
- The windshield glass is fogged up; a clear view of the road is obstructed.
- Placing objects on the dashboard, etc.
- The sensor cannot detect the lane because of fog, heavy rain or snow.

### **LKA system function change**

The driver can change LKA to the Lane Departure Warning (LDW) system or change the LKA system mode from the LCD display. Go to the "User Settings → Driver Assistance → Lane Safety → Lane Keeping Assist (LKA)/Lane Departure Warning (LDW)/Active LKA".

The system is automatically set to Lane Keeping Assist(LKA) if a function is not selected.

### ***Lane Keeping Assist (LKA)***

This mode guides the driver to help keep the vehicle within the lanes. It rarely controls the steering wheel, when the vehicle drives well inside the lanes. However, it starts to control the steering wheel, when the vehicle is about to deviate out of the lane.

### ***Lane Departure Warning (LDW)***

LDW system alerts the driver with a visual warning and a warning alarm when the system detects the vehicle departing the lane. The steering wheel will not be controlled.

### ***Active LKA***

The active LKA mode provides more frequent steering wheel control in comparison with the LKA mode. Active LKA can reduce the driver's fatigue to assist the steering for maintaining the vehicle in the middle of the lane.



## DRIVER ATTENTION WARNING (DAW) SYSTEM (IF EQUIPPED)

The Driver Attention Warning (DAW) system displays the condition of the driver's fatigue level and inattentive driving practices.

### System setting and activation

#### System setting

- The Driver Attention Warning (DAW) system is set to be in the ON position, when your vehicle is first delivered to you from the factory.
- To turn ON the Driver Attention Warning (DAW) system, turn on the engine, and then select "User Settings → Driver Assistance → Driver Attention Warning → High Sensitivity/Normal Sensitivity" on the LCD display.

- The driver can select the Driver Attention Warning (DAW) system mode.
  - Off : The Driver Attention Warning (DAW) system is deactivated.
  - Normal Sensitivity : The Driver Attention Warning (DAW) system alerts the driver of his/her fatigue level or inattentive driving practices.
  - High Sensitivity : The Driver Attention Warning (DAW) system alerts the driver of his/her fatigue level or inattentive driving practices faster than Normal mode.
- The set-up of the Driver Attention Warning (DAW) system will be maintained, as selected, when the engine is re-started.

### Display of the driver's attention level

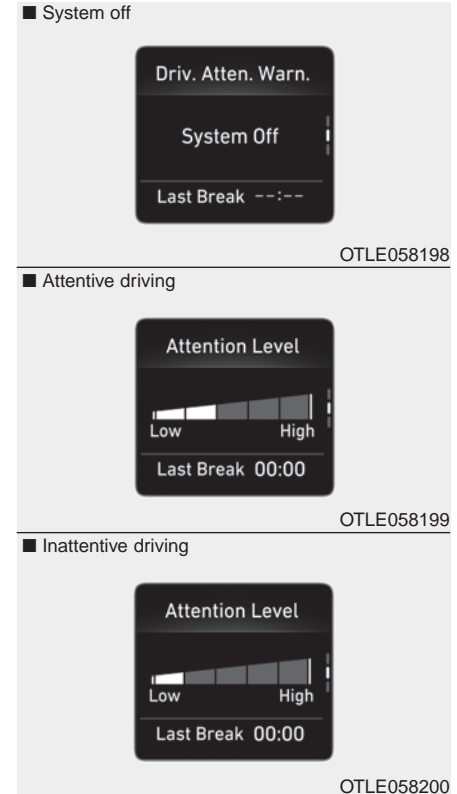

- The driver can monitor their driving conditions on the LCD display.

The DAW screen will appear when you select the ASSIST mode tab (A) on the LCD display if the system is activated. **(For more details, refer to "LCD Display Modes" in chapter 3.)**

- The driver's attention level is displayed on the scale of 1 to 5. The lower the level is, the more inattentive the driver is.
- The level decreases when the driver does not take a break for a certain period of time.
- The level increases when the driver attentively drives for a certain period of time.
- When the driver turns on the system while driving, it displays 'Last Break time' and level.

### Take a break



- The "Consider taking a break" message appears on the LCD display and a warning sounds in order to suggest the driver to take a break, when the driver's attention level is below 1.
- The Driver Attention Warning (DAW) system does not suggest the driver to take a break, when the total driving time is shorter than 10 minutes.

### Resetting the system

- The last break time is set to 00:00 and the driver's attention level is set to 5 (very attentive) when the driver resets the Driver Attention Warning (DAW) system.
- The Driver Attention Warning (DAW) system resets the last break time to 00:00 and the driver's attention level to 5 in the following situations.
  - The engine is turned OFF.
  - The driver unfastens the seat belt and then opens the driver's door.
  - The vehicle is stopped for more than 10 minutes.
- The Driver Attention Warning (DAW) system operates again, when the driver restarts driving.

## System standby



The Driver Attention Warning (DAW) system enters the ready status and displays the 'Standby' screen in the following situations.

- The camera does not detect the lane.
- Driving speed remains under 60 km/h (37 mph) or over 180 km/h (112 mph).

## System malfunction



### Check Driver Attention Warning (DAW) system

When the "Check Driver Attention Warning (DAW) system" warning message appears, the system is not working properly. In this case, we recommend that you have the vehicle inspected by an authorized HYUNDAI dealer.

## ⚠ WARNING

- The Driver Attention Warning (DAW) system is not a substitute for safe driving practices, but a convenience function only. It is the responsibility of the driver to always drive cautiously to prevent unexpected and sudden situations from occurring. Pay attention to the road conditions at all times.
- The system may suggest a break according to the driver's driving pattern or habits even if the driver doesn't feel fatigued.
- The driver, who feels fatigued, should take a break, even though there is no break suggestion by the Driver Attention Warning (DAW) system.

**NOTICE**

The Driver Attention Warning (DAW) system utilizes the camera sensor on the front windshield for its operation. To keep the camera sensor in the best condition, you should observe the followings:

- NEVER install any accessories or stickers on the front windshield, nor tint the front windshield.
- NEVER locate any reflective objects (i.e. white paper, mirror) over the dashboard. Any light reflection may cause a malfunction of the Driver Attention Warning (DAW) system.
- Pay extreme caution to keep the camera sensor out of water.
- NEVER disassemble the camera assembly, nor apply any impact on the camera assembly.

(Continued)

(Continued)

- Do not disassemble the camera temporarily for tinted window or attaching any types of coatings and accessories. If you disassemble a camera and assemble it again, we recommend that you take your vehicle to an authorized HYUNDAI dealer and have the system checked for calibration.



**CAUTION**

The Driver Attention Warning (DAW) system may not properly operate with limited alerting in the following situations:

- The lane detection performance is limited. (For more details, refer to "Lane Keeping Assist (LKA) system" in this chapter.)
- The vehicle is violently driven or is abruptly turned for obstacle avoidance (e.g. construction area, other vehicles, fallen objects, bumpy road).
- Forward drivability of the vehicle is severely undermined (possibly due to wide variation in tire pressures, uneven tire wear-out, toe-in/toe-out alignment).

(Continued)

(Continued)

- The vehicle drives on a curvy road.
- The vehicle drives through a windy area.
- The vehicle drives on a bumpy road.
- The vehicle is controlled by the following driving assist systems:
  - Lane Keeping Assist (LKA) system
  - Forward Collision-avoidance Assist (FCA) system
  - Smart Cruise Control (SCC) system



## CAUTION

Playing the vehicle audio system at high volume may offset the Driver Attention Warning (DAW) system warning sounds.

## SPEED LIMIT CONTROL SYSTEM (IF EQUIPPED)

### Speed Limit Control Operation

You can set the speed limit when you do not want to drive over a specific speed.

If you drive over the preset speed limit, the warning system operates (set speed limit will blink and chime will sound) until the vehicle speed returns within the speed limit.

### **i** Information

**While speed limit control is in operation, the cruise control system cannot be activated.**

### Speed limit control switch

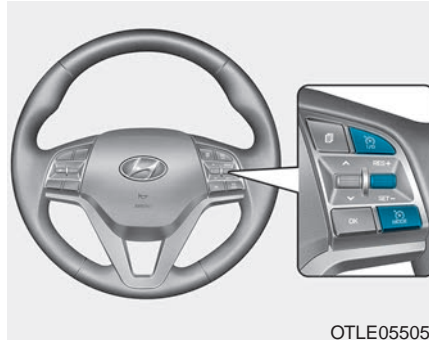

OTLE055056

 : Turns speed limit control system on or off.

 : Changes mode between cruise control system and speed limit control system.

System off → Cruise Control

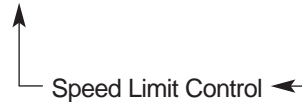

RES+: Resumes or increases speed limit control speed.

SET-: Sets or decreases speed limit control speed.



### To set speed limit

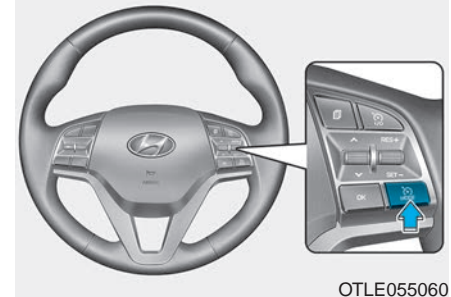

OTLE055057



OTLE055060

1. Press the  button on the steering wheel, and then press the  button to turn the system on. The speed limit indicator in the instrument cluster will illuminate.

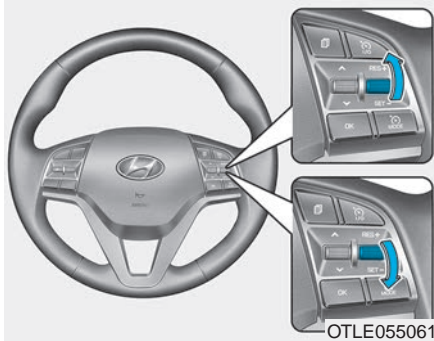

2. Push the lever down (SET-).
3. • Push the lever up (RES+) or down (SET-), and release it at the desired speed.
  - Push the lever up (RES+) or down (SET-) and hold it. The speed will increase or decrease by 5 km/h.



The set speed limit will display on the instrument cluster.

If you would like to drive over the pre-set speed limit when you depress the accelerator pedal less than approximately 50%, the vehicle speed will maintain within speed limit.

However if you depress the accelerator pedal more than approximately 70%, you can drive over the speed limit. Then the set speed limit will blink and chime will sound until you return the vehicle speed within the speed limit.

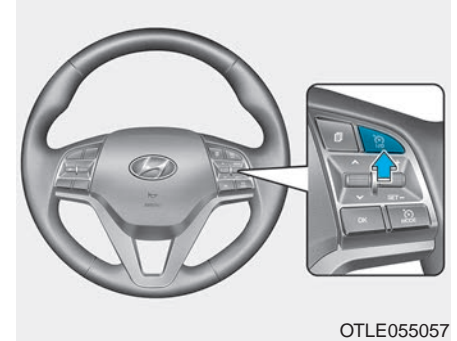
**To turn off the speed limit control, do one of the following:**



- Press the  button.
- Press the  button. The Cruise Control System will turn on.

## INTELLIGENT SPEED LIMIT WARNING (ISLW) SYSTEM (IF EQUIPPED)

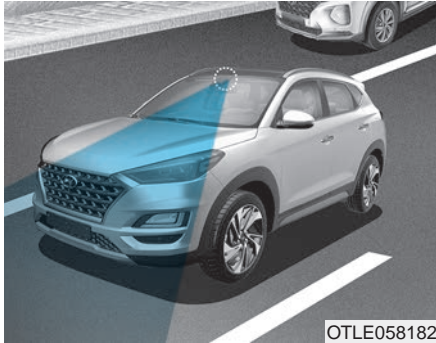

The ISLW displays the speed limit information and overtaking restriction of current road and detail conditional through the instrument cluster and the navigation. The ISLW reads the traffic signs through the camera, which is attached on the upper part of the inner front windshield.

The ISLW also utilizes the navigation and vehicle information to display the speed limit information.

### WARNING

- Intelligent Speed Limit Warning (ISLW) system is only a supplemental system and is not always able to correctly display speed limits and overtaking restrictions.
- The driver still holds the responsibility not to exceed the maximum speed limit.
- Do not install any accessories and stickers. Do not tint the front windshield, especially near the rearview mirror.
- The ISLW detects the traffic signs through the camera to display the speed limit information.

Therefore, the ISLW may not properly operate, when it is hard to detect the traffic signs. For further details, please refer to the "Limitations of the system".

(Continued)

(Continued)

- Pay extreme caution to keep the camera sensor out of water.
- Do not arbitrarily disassemble the camera assembly, nor apply any impact on the camera assembly.
- Do not disassemble camera temporarily for tinted window or attaching any types of coatings and accessories. If you disassemble a camera and assemble it again, take your vehicle to an authorized HYUNDAI dealer and have the system checked to need a calibration.
- Do not locate any reflective objects (i.e. white paper, mirror) over the dashboard. Any light reflection may cause a malfunction system.
- The system is not available in all countries.



## **i** Information

We recommend that you have the system checked by an authorized HYUNDAI dealer when:

- The windshield glass is replaced.
- The camera or related parts are repaired or removed.

## System setting and activation

### System setting

- The driver can activate the Speed Limit Warning by selecting 'User Settings → Driver Assistance → Speed Limit Warning'.
- When the ISLW is activated, the symbols appear on the instrument cluster to display the speed limit information and overtaking restriction.
- When the ISLW is activated in the navigation setting, the above information and the restriction are also displayed on the navigation.

### System activation

- The ISLW displays the speed limit information and alerts the overtaking restriction, when your vehicle passes by the relevant traffic signs.
- With the ignition switch in the ON position, the driver can activate the ISLW by selecting 'User Settings → Driver assistance → Speed Limit Warning'.
- The ISLW displays the previous speed limit information, right after the ignition switch is placed to the ON position.
- You may find different speed limit information for the same road. The information is displayed depending on the driving situations. Because, traffic signs with additional sign (e.g. rainy, arrow, etc.) are also detected and compared with vehicle internal data (e.g. wiper operation, turn signal, etc.).

## **i** Information

The speed limit information on the instrument cluster may differ from the one on the navigation. In this case, check the speed unit setting on the navigation.

### Display

#### ■ No reliable speed limit information

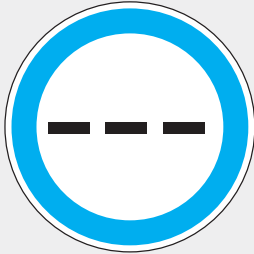

WTL-220

- The symbol is displayed on the instrument cluster and the navigation, when the ISLW does not have any reliable speed limit information.

#### ■ No passing information

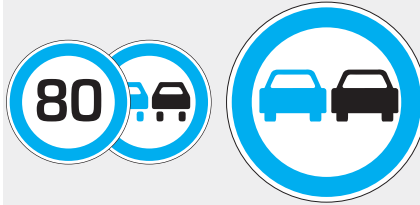

WTL-222/WTL-221

- The symbol is displayed on the instrument cluster and the navigation, when the ISLW detects a no-overtaking sign.

#### ■ Unlimited speed (only in Germany)



WUM-205

- The symbol, 'end of limitation', is displayed on the instrument cluster for the roads in Germany, which have no speed limit applicable. It is displayed, until the vehicle passes by another speed limit sign.

■ End of a speed limit

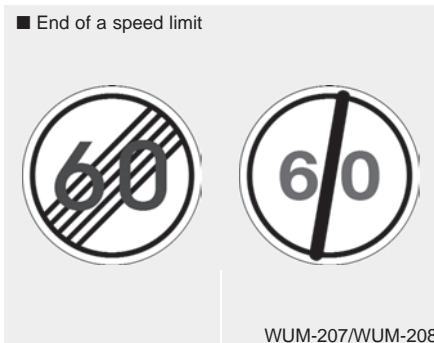

- After passing "end of speed limitation" sign Intelligent Speed Limit Warning provides information from navigation to inform driver of perhaps afterwards applicable speed limit.

### Warning message

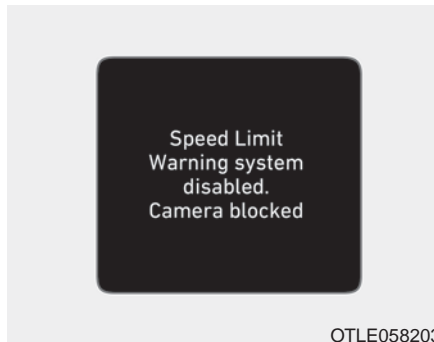

#### Speed Limit Warning system disabled. Camera obscured

The warning message appears, when the camera lens is blocked by some objects. The Intelligent Speed Limit Warning (ISLW) system does not operate, until the objects are removed. Check the windshield glass around the camera area. If the problem persists after removing the objects, we recommend that you have the system checked by an authorized HYUNDAI dealer.

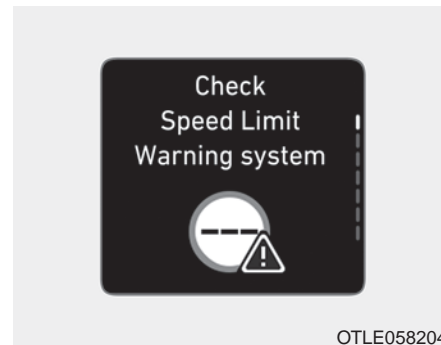

#### Check Speed Limit Warning system

The warning message appears for a few seconds, when the ISLW does not properly operate. Then, the master warning light (⚠) will illuminate. We recommend that you have the system checked by an authorized HYUNDAI dealer.

### Limitations of the system

The ISLW may not operate properly or may not provide correct information in the following situations.

#### When the traffic sign condition is poor

- The traffic sign is located on a sharp curve.
- The traffic sign is improperly positioned (i.e. turned over, blocked by an object, and damaged).
- Another vehicle blocks the traffic sign.
- The LED light of the traffic sign is broken.
- There is sunlight glare around the traffic sign due to low solar altitude.
- It is dark at night.
- There is bright light around the traffic sign.
- If road signs do not correspond to the standard and etc.
- The conditional road sign is indicated by letter, not specified image such as trailer, rain or snow.

#### When external condition is intervened

- Your vehicle drives right after another vehicle.
- The bus or truck, on which the speed sticker is attached, passes by your vehicle.
- Your vehicle drives in an area, which is uncovered by the navigation system.
- There is a malfunction with the navigation
- Your navigation has not been updated.
- Your navigation is being updated.
- As a result of incorrect detection by the camera.
- The top speed limitations stored in the navigation system are incorrect.
- The camera is calibrated right after the vehicle is delivered.
- There is something wrong with GPS.

- If the ISLW does not recognize normally vehicle status such as outside temperature, the ISLW cannot display the conditional road sign instead of road sign of current road.

#### When front visibility is poor

- The weather is bad, such as raining, snowing, and fogging.
- There is dirt, ice or frost on the front windshield, where the camera is installed.
- The camera lens is blocked by an object, such as sticker, paper, or fallen leaf.

---

## Driver's attention

The ISLW may not assist the driver and may not properly operate.

- The ISLW is only to assist the driver. The driver should pay great caution to the vehicle operation.
- The driver always holds the responsibility of safe driving by following the applicable road traffic rule(s) and regulation(s).

## CRUISE CONTROL (WITH SPEED LIMIT CONTROL) (IF EQUIPPED)

### Cruise Control Operation



1. CRUISE indicator
2. SET speed

The Cruise Control system allows you to drive at speeds above 30 km/h (20 mph) without depressing the accelerator pedal.

### WARNING

Take the following precautions:

- If the Cruise Control is left on, (CRUISE indicator light in the instrument cluster illuminated) the Cruise Control can be activated unintentionally. Keep the Cruise Control system off ( indicator light OFF) when the Cruise Control is not in use, to avoid inadvertently setting a speed.
- Use the Cruise Control system only when traveling on open highways in good weather.
- Do not use cruise control when towing a trailer.
- Do not use the Cruise Control when it may be unsafe to keep the vehicle at a constant speed:
  - Driving in heavy or varying speed traffic.
  - On slippery (rainy, icy or snow covered) roads.

(Continued)

(Continued)

- Hilly or winding roads.
- Very windy areas.
- When driving with limited view (possibly due to bad weather such as fog, snow, rain and sandstorm)

### NOTICE



During cruise-speed driving of a manual transaxle vehicle, do not shift into neutral without depressing the clutch pedal, since the engine will be overrevved. If this happens, depress the clutch pedal or press the cruise control ON / OFF button.

## **i** Information

- During normal cruise control operation, when the SET switch is activated or reactivated after applying the brakes, the cruise control will energize after approximately 3 seconds. This delay is normal.
- To activate cruise control, depress the brake pedal at least once after turning the ignition switch to the ON position or starting the engine. This is to check if the brake switch which is important part to cancel cruise control is in normal condition.

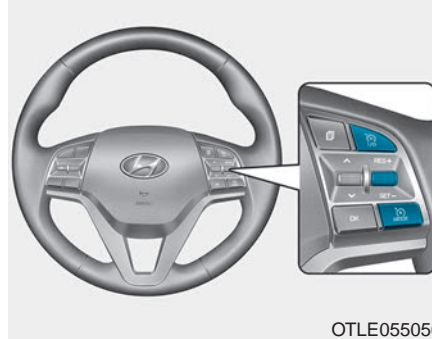

### **Cruise control switch**

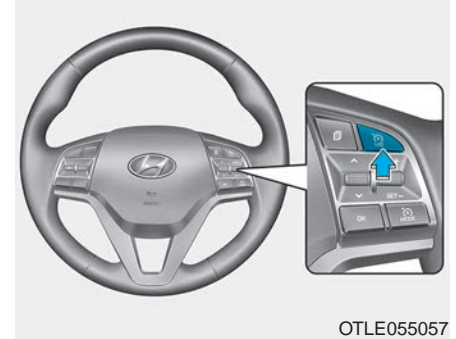

-  : Turns cruise control system on or off.
-  : Changes mode between cruise control system and speed limit control system.
- RES+ : Resumes or increases cruise control speed.
- SET- : Sets or decreases cruise control speed.

### **To set Cruise Control speed**



1. Press the  button on the steering wheel to turn the system on. The  indicator will illuminate.
2. Accelerate to the desired speed, which must be more than 30 km/h (20 mph).

## **i** Information

For manual transaxle vehicles, you should depress the brake pedal at least once to set the cruise control after starting the engine.

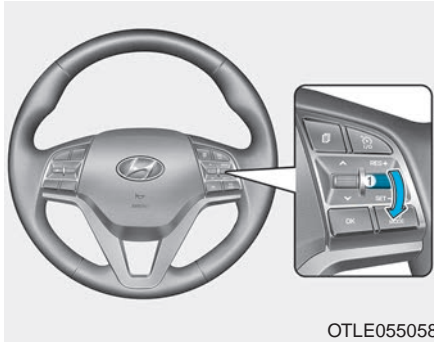

OTLE055058

3. Push the lever (1) down (SET-), and release it. The set speed on the LCD display will illuminate.
4. Release the accelerator pedal.

### **i** Information

**On a steep slope, the vehicle may slightly slow down or speed up, while driving uphill or downhill.**

### **To increase Cruise Control speed**

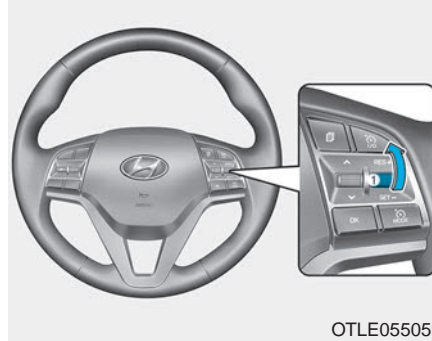

OTLE055059

- Push the lever (1) up (RES+) and hold it, while monitoring the SET speed on the instrument cluster. Release the lever when the desired speed is shown and the vehicle will accelerate to that speed.
- Push the lever (1) up (RES+) and release it immediately. The cruising speed will increase 1.0 km/h (1.0 mph) each time the lever is operated in this manner.

- Depress the accelerator pedal. When the vehicle attains the desired speed, push the lever (1) down (SET-).



### **To decrease Cruise Control speed**

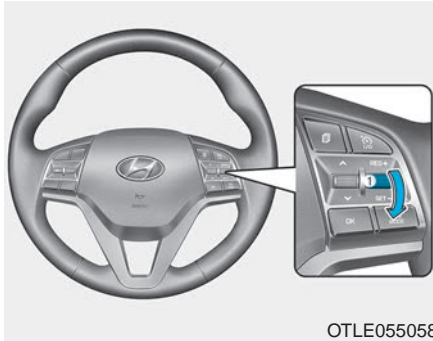

- Push the lever (1) down (SET-) and hold it. Your vehicle will gradually slow down. Release the lever at the speed you want to maintain.
- Push the lever (1) down (SET-) and release it immediately. The cruising speed will decrease 1.0 km/h (1.0 mph) each time the lever is operated in this manner.
- Lightly tap the brake pedal. When the vehicle attains the desired speed, push the lever (1) down (SET-).



### **To temporarily accelerate with the Cruise Control ON**

Depress the accelerator pedal. When you take your foot off the accelerator, the vehicle will return to the previously set speed.

If you push the lever down (SET-) at the increased speed, the Cruise Control will maintain the increased speed.

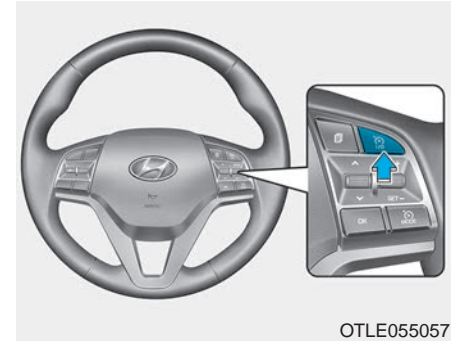

### **Cruise Control will be canceled when:**



- Depressing the brake pedal.
- Depressing the clutch pedal. (for manual transaxle vehicle)
- Pressing the  button located on the steering wheel.
- Pressing the  button. The Speed Limit Control System will turn on.
- Moving the shift lever into N (Neutral). (for automatic transaxle / dual clutch transmission vehicle)

- Decreasing the vehicle speed lower than the memory speed by 20 km/h (12 mph).
- Decreasing the vehicle speed to less than approximately 30 km/h (20 mph).
- The ESC (Electronic Stability Control) is operating.
- Downshifting to the 2nd gear in Sports Mode.

### **i** Information

Each of the above actions will cancel Cruise Control operation (The set speed on the instrument cluster will go off), but only pressing the  button will turn the system off. If you wish to resume Cruise Control operation, push the lever up (RES+) located on your steering wheel. You will return to your previously preset speed, unless the system was turned off using the  button.

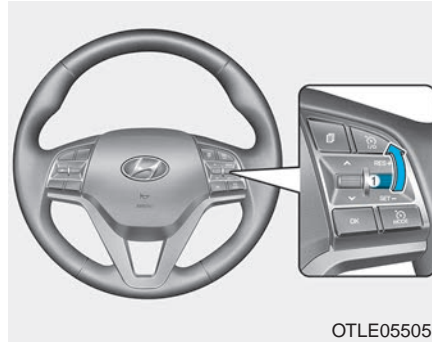

### **To resume preset Cruising speed**

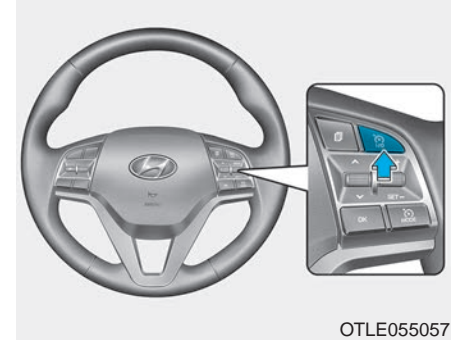

Push the lever (1) up (RES+). If the vehicle speed is over 30 km/h (20 mph), the vehicle will resume the preset speed.

### **To turn Cruise Control off**



- Press the  button (the  indicator will go off).
- Turn the engine OFF.

## CRUISE CONTROL (IF EQUIPPED)

### Cruise Control operation



1. CRUISE indicator
2. SET speed

The Cruise Control system allows you to drive at speeds above 30 km/h (20 mph) without depressing the accelerator pedal.

### **WARNING**

Take the following precautions:

- If the Cruise Control is left on, (CRUISE indicator light in the instrument cluster is illuminated) the Cruise Control can be activated unintentionally. Keep the Cruise Control system off (CRUISE indicator light OFF) when the Cruise Control is not in use, to avoid inadvertently setting a speed.
- Use the Cruise Control system only when traveling on open highways in good weather.
- Do not use cruise control when towing a trailer.

(Continued)

(Continued)

- Do not use the Cruise Control when it may be unsafe to keep the vehicle at a constant speed:
  - Driving in heavy or varying speed traffic.
  - On slippery (rainy, icy or snow covered) roads.
  - Hilly or winding roads.
  - Very windy areas.
  - When driving with limited view (possibly due to bad weather such as fog, snow, rain and sandstorm)

### **NOTICE**

During cruise-speed driving of a manual transaxle vehicle, do not shift into neutral without depressing the clutch pedal, since the engine will be overrevved. If this happens, depress the clutch pedal or press the cruise control ON / OFF button.

**i** Information

- During normal cruise control operation, when the SET switch is activated or reactivated after applying the brakes, the cruise control will energize after approximately 3 seconds. This delay is normal.
- To activate cruise control, depress the brake pedal at least once after turning the ignition switch to the ON position or starting the engine. This is to check if the brake switch which is important part to cancel cruise control is in normal condition.

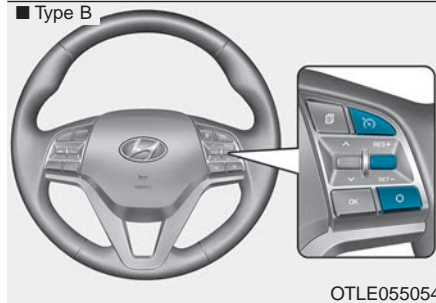
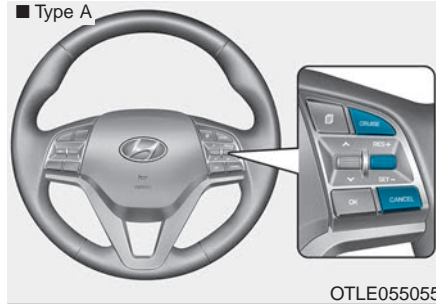

**Cruise control switch**

CANCEL/O : Cancels cruise control operation.

CRUISE / (cruise icon) : Turns cruise control system on or off.

RES+: Resumes or increases cruise control speed.

SET-: Sets or decreases cruise control speed.

**To set Cruise Control speed**

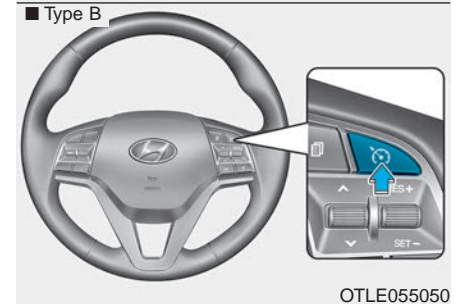
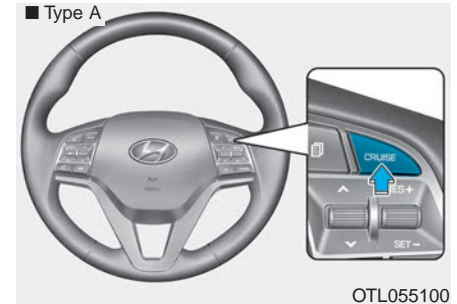

1. Press the CRUISE / (cruise icon) button on the steering wheel to turn the system on. The CRUISE indicator will illuminate.

2. Accelerate to the desired speed, which must be more than 30 km/h (20 mph).

**i Information - Manual transaxle**

For manual transaxle vehicles, you should depress the brake pedal at least once to set the cruise control after starting the engine.

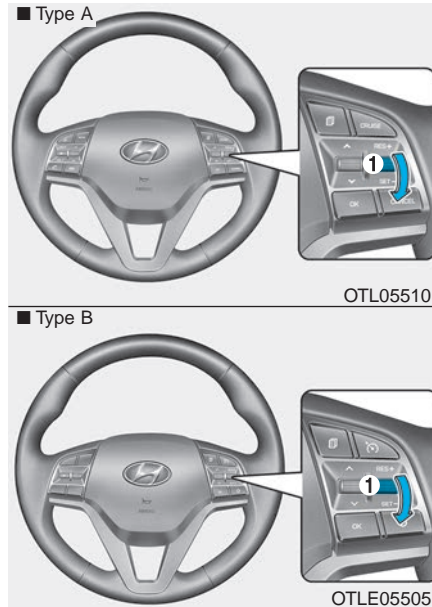

3. Push the lever (1) down (SET -), and release it. The set speed on the LCD display will illuminate.
4. Release the accelerator pedal.

**i Information**

On a steep slope, the vehicle may slightly slow down or speed up, while driving uphill or downhill.

### To increase Cruise Control speed

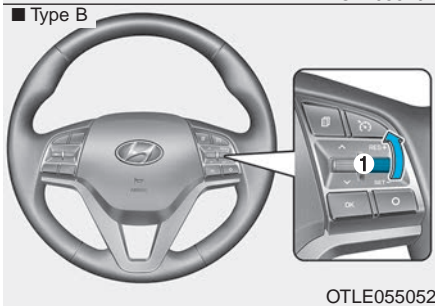
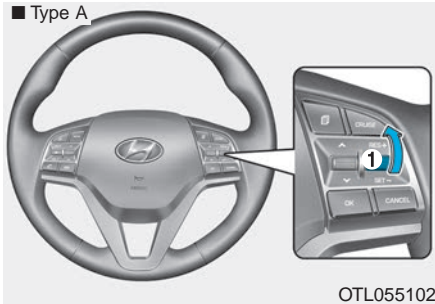

- Push the lever (1) up (RES+) and hold it, while monitoring the SET speed on the instrument cluster.

Release the lever when the desired speed is shown and the vehicle will accelerate to that speed.

- Push the lever (1) up (RES+) and release it immediately. The cruising speed will increase 1.0 km/h (1.0 mph) each time the lever is operated in this manner.
- Depress the accelerator pedal. When the vehicle attains the desired speed, push the lever (1) down (SET-).

### To decrease Cruise Control speed

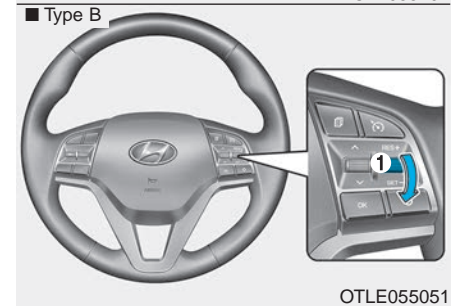
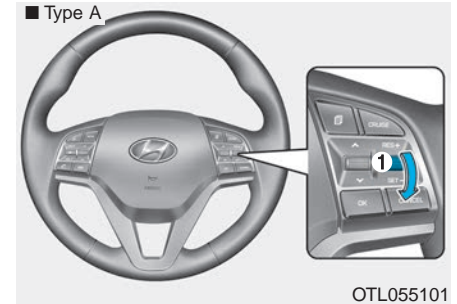

- Push the lever (1) down (SET-) and hold it. Your vehicle will gradually slow down. Release the lever at the speed you want to maintain.

- Push the lever (1) down (SET-) and release it immediately. The cruising speed will decrease 1.0 km/h (1.0 mph) each time the lever is operated in this manner.
- Lightly tap the brake pedal. When the vehicle attains the desired speed, push the lever (1) down (SET-).

***To temporarily accelerate with the Cruise Control ON***

Depress the accelerator pedal. When you take your foot off the accelerator, the vehicle will return to the previously set speed.

If you push the lever down (SET-) at the increased speed, the Cruise Control will maintain the increased speed.

***Cruise Control will be canceled when:***

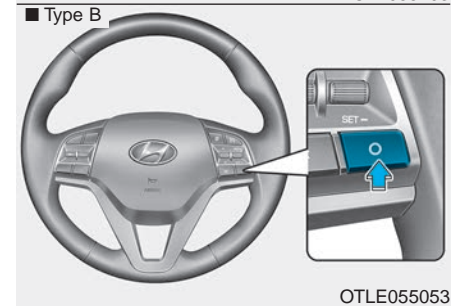
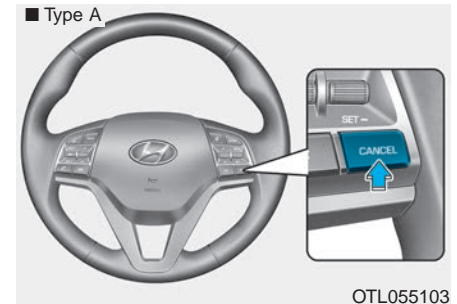

- Depressing the brake pedal.
- Depressing the clutch pedal. (for manual transaxle vehicle)



- Pressing the CANCEL / O button located on the steering wheel.
- Pressing the CRUISE /  button. Both the CRUISE indicator and the SET indicator will turn OFF.
- Moving the shift lever into N (Neutral). (for automatic transaxle / dual clutch transmission vehicle)
- Decreasing the vehicle speed lower than the speed by 20 km/h (12 mph).
- Decreasing the vehicle speed to less than approximately 30 km/h (20 mph).
- The ESC (Electronic Stability Control) is operating.
- Downshifting to the 2nd gear in Sports Mode.

### Information

Each of the above actions will cancel Cruise Control operation (The set speed on the instrument cluster will go off), but only pressing the CRUISE button will turn the system off. If you wish to resume Cruise Control operation, push the lever up (RES+) located on your steering wheel. You will return to your previously preset speed, unless the system was turned off using the CRUISE button.

### *To resume preset Cruising speed*

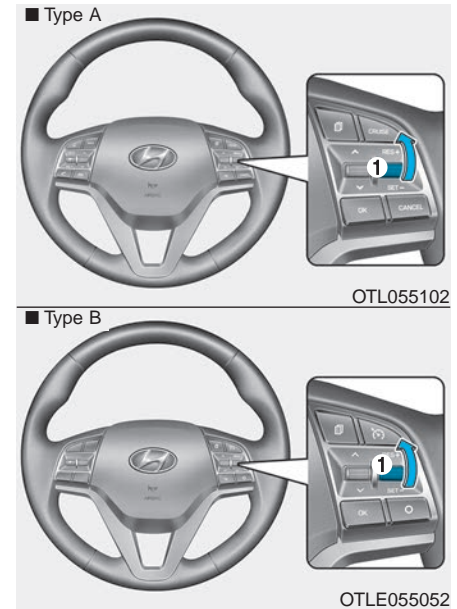

Push the lever (1) up (RES+). If the vehicle speed is over 30 km/h (20 mph), the vehicle will resume the preset speed.



## To turn Cruise Control off

### ■ Type A

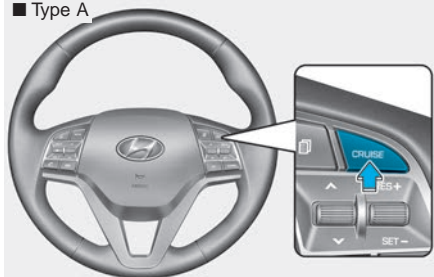

OTL055100

### ■ Type B

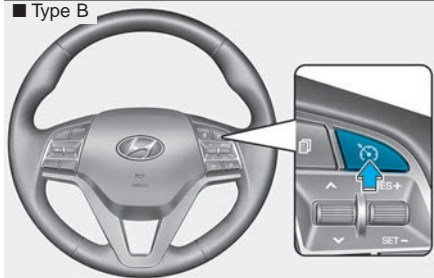

OTLE055050

- Press the CRUISE /  button (the CRUISE indicator light will go off).
- Turn the engine OFF.

## SMART CRUISE CONTROL WITH STOP & GO SYSTEM (IF EQUIPPED)



- ① Cruise indicator
- ② Set speed
- ③ Vehicle-to-vehicle distance

To see the SCC screen on the LCD display on the cluster, select Assist mode (A). For more details, refer to “LCD Display Modes” in chapter 3.

The Smart Cruise Control system allows you to program the vehicle to maintain constant speed and minimum distance between the vehicle ahead.

The Smart Cruise Control system will automatically adjust your vehicle speed to maintain your programmed speed and following distance without requiring you to depress the accelerator or brake pedals.

### ⚠ WARNING

**For your safety, please read the owner's manual before using the Smart Cruise Control system.**

### ⚠ WARNING

**The Smart Cruise Control system is not a substitute for safe driving practices, but a convenience function only. It is the responsibility of the driver to always check the speed and distance to the vehicle ahead.**

## Smart Cruise Control Switch

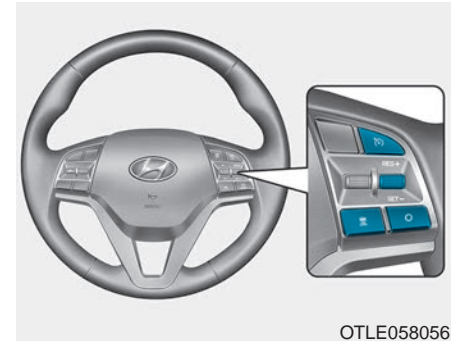

- CRUISE/Ⓢ: Turns cruise control system on or off.
- RES+: Resumes or increases cruise control speed.
- SET-: Sets or decreases cruise control speed.
- Ⓢ: Sets vehicle-to-vehicle distance.
- CANCEL/O: Cancels cruise control operation.

## Smart Cruise Control speed

### To set Smart Cruise Control speed

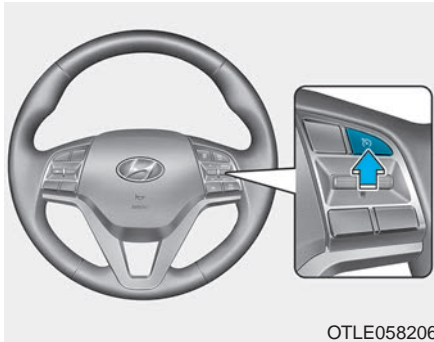

1. Push the CRUISE/ON button on the steering wheel to turn the system on. The cruise indicator will illuminate.

2. Accelerate to the desired speed.

The Smart Cruise Control speed can be set as follows:

- 30 km/h (20 mph) ~ 180 km/h (110 mph) : when there is no vehicle in front
- 0 km/h (0 mph) ~ 180 km/h (110 mph) : when there is a vehicle in front

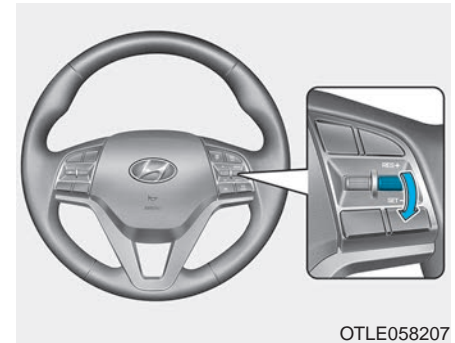

3. Push the toggle switch down (SET-). The Set Speed and Vehicle-to-Vehicle Distance on the LCD display will illuminate.
4. Release the accelerator pedal. The desired speed will automatically be maintained.

If there is a vehicle in front of you, the speed may decrease to maintain the distance to the vehicle ahead.

On a steep grade, the vehicle may slow down or speed up slightly while going uphill or downhill.

**i** Information

- Vehicle speed may decrease on an upward slope and increase on a downward slope.
- When you are setting the cruise control speed, with a vehicle in front and your vehicle speed is between 0 ~ 30 km/h (0 ~ 20 mph), the speed will set to 30 km/h (20 mph).

**To increase Smart Cruise Control set speed**

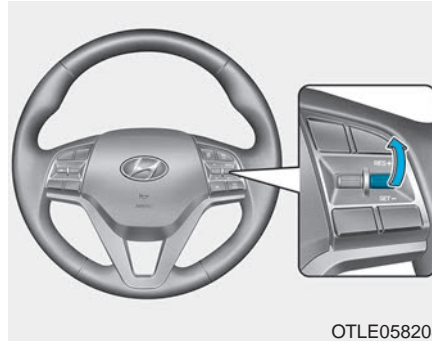

Follow either of these procedures:

- Push the toggle switch up (RES+), and release it immediately. The cruising speed will increase by 1 km/h (1 mph) each time you move the toggle switch up in this manner.
- Push the toggle switch up (RES+), and hold it. Your vehicle set speed will increase by 10 km/h (5 mph). Release the toggle switch at the speed you want.
- You can set the speed to 180 km/h (110 mph).

**⚠ CAUTION**

Check the driving condition before using the toggle switch. Driving speed sharply increases, when you push up and hold the toggle switch.

### **To decrease the Smart Cruise Control set speed**

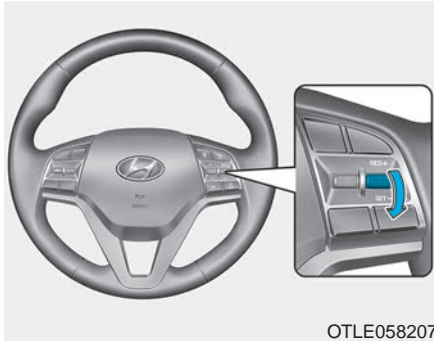

Follow either of these procedures:

- Push the toggle switch down (SET-), and release it immediately. The cruising speed will decrease by 1 km/h (1 mph) each time you move the toggle switch down in this manner.
- Push the toggle switch down (SET-), and hold it. Your vehicle set speed will decrease by 10 km/h (5 mph). Release the toggle switch at the speed you want.
- You can set the speed to 30 km/h (20 mph).

### **To temporarily accelerate with the Smart Cruise Control on**

If you want to speed up temporarily when the Smart Cruise Control is on, depress the accelerator pedal. Increased speed will not interfere with Smart Cruise Control operation or change the set speed.

To return to the set speed, take your foot off the accelerator pedal.

If you push the toggle switch down (SET-) at increased speed, the cruising speed will be set again.

### **i Information**

**Be careful when accelerating temporarily, because the speed is not controlled automatically at this time even if there is a vehicle in front of you.**

**Smart Cruise Control will be temporarily canceled when:**

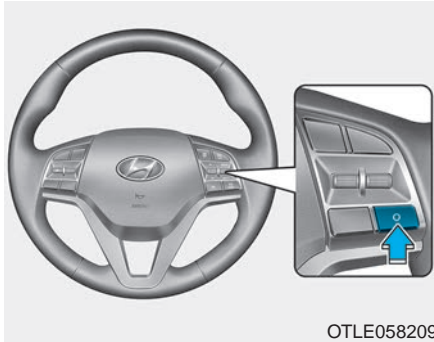

**Cancelled manually**

- Depressing the brake pedal.
- Pushing the CANCEL/O button located on the steering wheel.

The Smart Cruise Control turns off temporarily when the Set Speed and Vehicle-to-Vehicle Distance indicator on the LCD display turns off.

The cruise indicator is illuminated continuously.

**Cancelled automatically**

- The driver's door is opened.
- The vehicle is shifted to N (Neutral), R (Reverse) or P (Park).
- The parking brake is applied.
- The vehicle speed is over 190 km/h (120 mph).
- The ESC (Electronic Stability Control), TCS (Traction Control System) or ABS is operating.
- The ESC is turned off.
- The sensor or the cover is dirty or blocked with foreign matter.
- The vehicle is stopped for a certain period of time.
- The vehicle stops and goes repeatedly for a long period of time.
- The accelerator pedal is continuously depressed for a long period of time.
- The engine performance is abnormal.
- Engine rpm is in the red zone.

- The driver starts driving by pushing the toggle switch up (RES+)/down (SET-) or depressing the accelerator pedal, after the vehicle is stopped by the Smart Cruise Control system with no other vehicle ahead.
- The driver starts driving by pushing the toggle switch up (RES+)/down (SET-) or depressing the accelerator pedal, after stopping the vehicle with a vehicle stopped far away in front.
- The Forward Collision-Avoidance Assist (FCA) is activated.

Each of these actions will cancel the Smart Cruise Control operation. The Set Speed and Vehicle-to-Vehicle Distance on the LCD display will go off.

In a condition the Smart Cruise Control is cancelled automatically, the Smart Cruise Control will not resume even though the RES+ or SET- toggle switch is pushed.

### **i** Information

**If the Smart Cruise Control is cancelled by other than the reasons mentioned, we recommend that the system be checked by an authorized HYUNDAI dealer.**

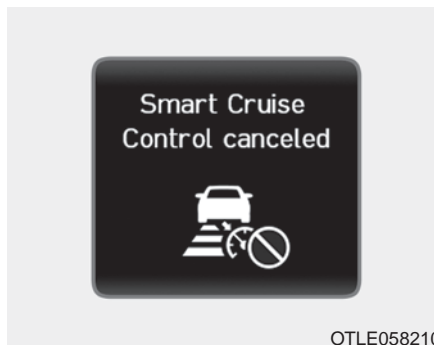

#### **Smart Cruise Control cancelled**

If the system is cancelled, the warning chime will sound and a message will appear for a few seconds.

You must adjust the vehicle speed by depressing the accelerator or brake pedal according to the road condition ahead and driving condition.

Always check the road conditions. Do not rely on the warning chime.

#### ***To resume Smart Cruise Control set speed***

If any method other than the cruise toggle switch was used to cancel cruising speed and the system is still activated, the cruising speed will automatically resume when you push the toggle switch up (RES+) or down (SET-).

If you push the toggle switch up (RES+), the speed will resume to the recently set speed. However, if vehicle speed drops below 30 km/h (20 mph), it will resume when there is a vehicle in front of your vehicle.

### **i** Information

**Always check the road conditions when you push the toggle switch up (RES+) to resume speed.**



### To turn Cruise Control off



- Pushing the CRUISE button. The cruise indicator will go off.  
If you wish not to use the cruise control system, always turn the system off by pushing the CRUISE button.

### WARNING

Take the following precautions :

- Always set the vehicle speed under the speed limit in your country.
- If the Smart Cruise Control is left on, ( CRUISE indicator light in the instrument cluster is illuminated) the Smart Cruise Control can be activated unintentionally. Keep the Smart Cruise Control system off ( CRUISE indicator light OFF) when the Smart Cruise Control is not in use, to avoid inadvertently setting a speed.
- Use the Smart Cruise Control system only when traveling on open highways in good weather.

(Continued)

(Continued)

- Do not use the Smart Cruise Control when it may not be safe to keep the vehicle at a constant speed:
  - When driving in heavy traffic or when traffic conditions make it difficult to drive at a constant speed
  - When driving on rainy, icy, or snow-covered roads
  - When driving on a steep downhill or uphill
  - When driving in windy areas
  - When driving in parking lots
  - When driving near crash barriers
  - When driving on a sharp curve
  - When driving with limited view (possibly due to bad weather, such as fog, snow, rain or sandstorm)

(Continued)



(Continued)

- When the vehicle sensing ability decreases due to vehicle modification resulting level difference of the vehicle's front and rear

- Unexpected situations may lead to possible accidents. Pay attention continuously to road conditions and driving even when the smart cruise control system is being operated.

## Smart Cruise Control Vehicle-to-Vehicle Distance

### To set Vehicle-to-Vehicle Distance

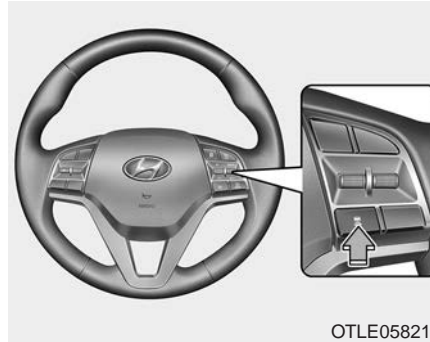

When the Smart Cruise Control system is ON, you can set and maintain the distance from the vehicle ahead of you without pressing the accelerator or brake pedal.

Each time the button is pressed, the vehicle to vehicle distance changes as follows:

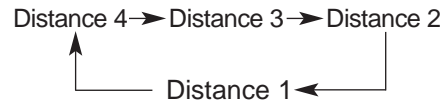

For example, if you drive at 90 km/h (56 mph), the distance maintain as follows:

Distance 4 - approximately 52.5 m

Distance 3 - approximately 40 m

Distance 2 - approximately 32.5 m

Distance 1 - approximately 25 m

### **i** Information

The distance is set to the last set distance when the system is used for the first time after starting the engine.

*When the lane ahead is clear:*



The vehicle speed will maintain the set speed.

*When there is a vehicle ahead of you in your lane:*

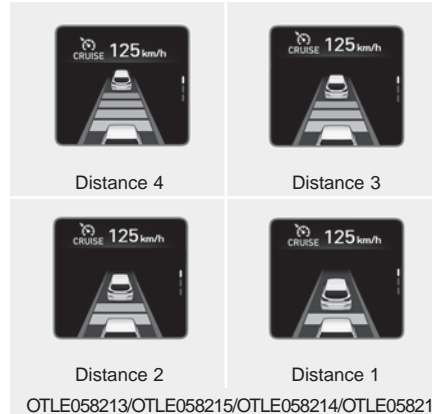

- Your vehicle speed will slow down or speed up to maintain the selected distance.
- If the vehicle ahead speeds up, your vehicle will travel at a steady cruising speed after accelerating to the set speed.
- If distance from the front vehicle has been changed due to accelerating or decelerating of front vehicle, the distance on the LCD may be changed.

**⚠ WARNING**



OTLE058217

**When using the Smart Cruise Control System:**

- **The warning message appears and warning chime sounds if the vehicle is unable to maintain the selected distance from the vehicle ahead.**
- **If the warning message appears and warning chime sounds, depress the brake pedal to actively adjust the vehicle speed, and the distance to the vehicle ahead.**

**(Continued)**

(Continued)

- Even if the warning message does not appear and warning chime does not sound, always pay attention to the driving conditions to prevent dangerous situations from occurring.
- Playing the vehicle audio system at high volume may offset the system warning sounds.

### ⚠ CAUTION



OTLE058218

If the vehicle ahead (vehicle speed: less than 30 km/h) disappears to the next lane, the warning chime will sound and a message "Watch for surrounding vehicles" will appear. Adjust your vehicle speed for vehicles or objects that can suddenly appear in front of you by depressing the brake pedal.

Always pay attention to the road condition ahead.

### *In traffic situation*

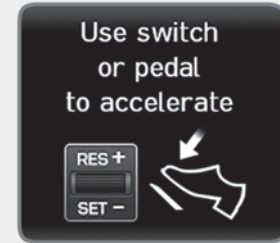

OTLE058219

### Use switch or pedal to accelerate

- In traffic, your vehicle will stop if the vehicle ahead of you stops. Also, if the vehicle ahead of you starts moving, your vehicle will start as well. However, if the vehicle stops for more than 3 seconds, you must depress the accelerator pedal or push up the toggle switch (RES+) or push down the toggle switch (SET-) to start driving.

- If you push the smart cruise control toggle switch (RES+ or SET-) while Auto Hold and advanced smart cruise control is operating the Auto Hold will be released regardless of accelerator pedal operation and the vehicle will start to move. The AUTO HOLD indicator changes from green to white. (if equipped with EPB (Electronic Parking Brake))

### Sensor to detect distance to the vehicle ahead



The Smart Cruise Control uses a sensor to detect distance to the vehicle ahead.

If the sensor is covered with dirt or other foreign matter, the vehicle to vehicle distance control may not operate correctly.

Always keep the sensor clean.

### Warning message



### Smart Cruise Control disabled. Radar blocked

When the sensor lens cover is blocked with dirt, snow, or debris, the Smart Cruise Control system operation may stop temporarily. If this occurs, a warning message will appear on the LCD display. Remove any dirt, snow, or debris and clean the radar sensor lens cover before operating the Smart Cruise Control system.

The Smart Cruise Control system may not properly activate, if the radar is totally contaminated, or if any substance is not detected after turning ON the engine (e.g. in an open terrain).

### **i** Information

For the SCC operation is temporarily stopped if the radar is blocked, but you wish to use cruise control mode (speed control function), you must convert to the cruise control mode (refer to "To convert to Cruise Control mode" in the following page.)

### CAUTION

- Do not apply license plate frame or foreign objects such as a bumper sticker or a bumper guard near the radar sensor. Doing so may adversely affect the sensing performance of the radar.
- Always keep the radar sensor and cover clean and free of dirt and debris.
- Use only a soft cloth to wash the vehicle. Do not spray pressurized water directly on the sensor or sensor cover.
- Be careful not to apply unnecessary force on the radar sensor or sensor cover. If the sensor is forcibly moved out of proper alignment, the Smart Cruise Control system may not operate correctly. In this case, a warning message may not be displayed. Have the vehicle inspected by an authorized HYUNDAI dealer.

(Continued)

### (Continued)

- If the front bumper becomes damaged in the area around the radar sensor, the Smart Cruise Control system may not operate properly. We recommend that you have the vehicle inspected by an authorized HYUNDAI dealer.
- Use only Hyundai parts to repair or replace a damaged sensor or sensor cover. Do not apply paint to the sensor cover.



### Check Smart Cruise Control System

The message will appear when the vehicle to vehicle distance control system is not functioning normally.

We recommend that you take your vehicle to an authorized HYUNDAI dealer and have the system checked.

### To adjust the sensitivity of Smart Cruise Control

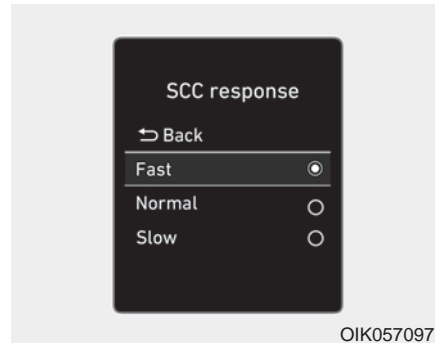

The sensitivity of vehicle speed when following the front vehicle to maintain the set distance can be adjusted. Go to the 'User Settings → Driver assistance → SCC response → Fast/Normal/Slow' on the LCD display. You may select one of the three stages you prefer.

- Fast:  
Vehicle speed following the front vehicle to maintain the set distance is faster than normal speed.
- Normal:  
Vehicle speed following the front vehicle to maintain the set distance is normal.
- Slow:  
Vehicle speed following the front vehicle to maintain the set distance is slower than normal speed.

### **i** Information

**The last selected speed sensitivity of the smart cruise control is remained in the system.**

## To convert to Cruise Control mode

The driver may choose to only use the conventional Cruise Control mode (speed control function) by doing as follows:

1. Turn the Smart Cruise Control System on (the cruise indicator light will be on but the system will not be activated).
2. Push and hold the Vehicle-to-Vehicle Distance button for more than 2 seconds.
3. Choose between "Smart Cruise Control" and "Cruise Control".

When the system is canceled using the CRUISE/⊘ button or the CRUISE button is used after the engine is turned on, the Smart Cruise Control mode will turn on.

### WARNING

**When using the Cruise Control mode, you must manually adjust the distance to other vehicles by depressing the brake pedal. The system does not automatically adjust the distance to vehicles in front of you.**

## Limitations of the system

The Smart Cruise Control system may have limits to its ability to detect distance to the vehicle ahead due to road and traffic conditions.

### *On curves*

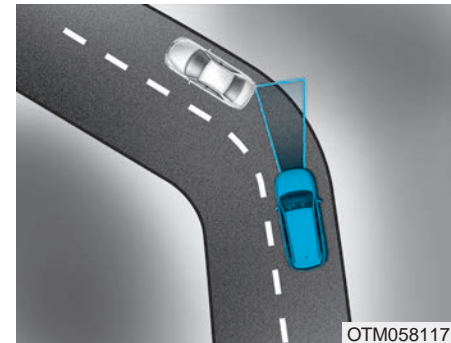

- The Smart Cruise Control system may not detect a moving vehicle in your lane, and then your vehicle could accelerate to the set speed. Also, the vehicle speed will decrease when the vehicle ahead is recognized suddenly.
- Select the appropriate set speed on curves and apply the brakes or accelerator pedal if necessary.



Your vehicle speed can be reduced due to a vehicle in the adjacent lane. Apply the accelerator pedal and select the appropriate set speed. Check to be sure that the road conditions permit safe operation of the Smart Cruise Control.

### ***On inclines***

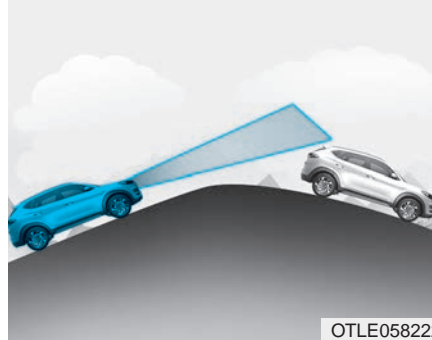

- During uphill or downhill driving, the Smart Cruise Control system may not detect a moving vehicle in your lane, and cause your vehicle to accelerate to the set speed. Also, the vehicle speed will rapidly decrease when the vehicle ahead is recognized suddenly.
- Select the appropriate set speed on inclines and apply the brake or accelerator pedal if necessary.

### ***Lane changing***

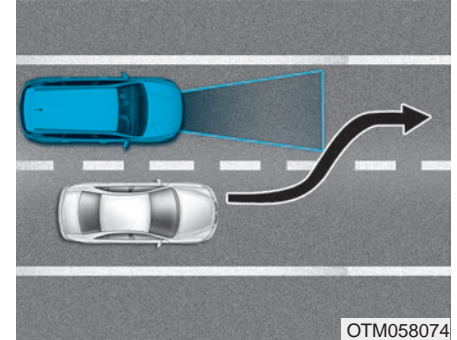

- A vehicle which moves into your lane from an adjacent lane cannot be recognized by the sensor until it is in the sensor's detection range.
- The radar may not detect immediately when a vehicle cuts in suddenly. Always pay attention to the traffic, road and driving conditions.
- If a slower vehicle moves into your lane, your speed may decrease to maintain the distance to the vehicle ahead.
- If a faster vehicle which moves into your lane, your vehicle will accelerate to the set speed.



## Vehicle recognition

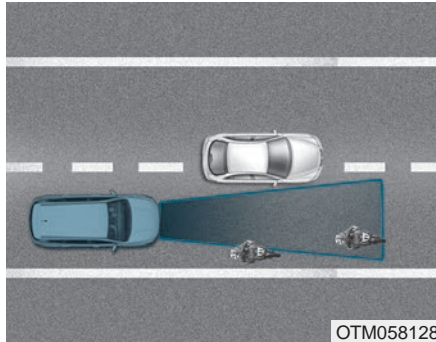

Some vehicles in your lane cannot be recognized by the sensor:

- Narrow vehicles such as motorcycles or bicycles
- Vehicles offset to one side
- Slow-moving vehicles or sudden-decelerating vehicles
- Stopped vehicles
- Vehicles with small rear profile such as trailers with no loads

A vehicle ahead cannot be recognized correctly by the sensor if any of the following occurs:

- When the vehicle is pointing upwards due to overloading in the luggage compartment
- While the steering wheel is operating
- When driving to one side of the lane
- When driving on narrow lanes or on curves

Apply the brake or accelerator pedal if necessary.

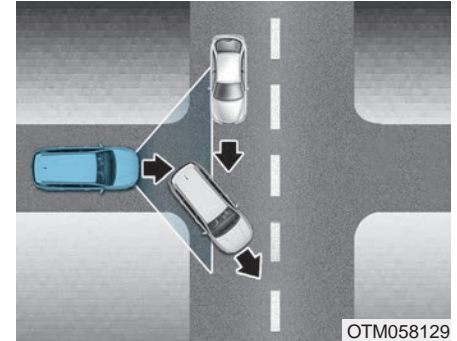

- Your vehicle may accelerate when a vehicle ahead of you disappears.
- When you are warned that the vehicle ahead of you is not detected, drive with caution.

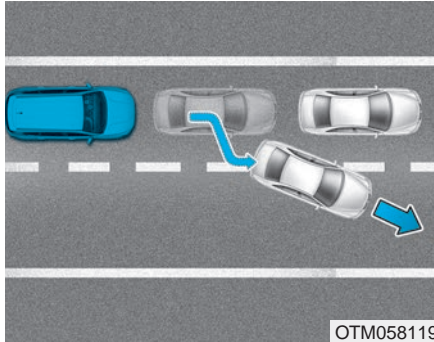

- When driving in stop-and-go traffic, and a stopped vehicle in front of you merges out of the lane, the system may not immediately detect the new vehicle that is now in front of you. In this case, you must maintain a safe braking distance, and if necessary, depress the brake pedal to reduce your driving speed in order to maintain a safe distance.

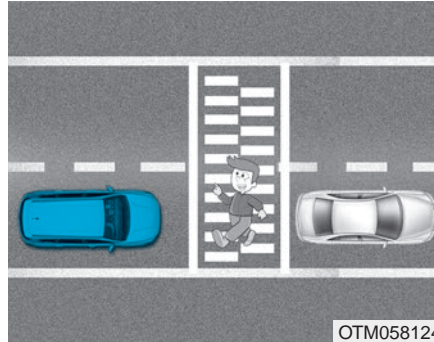

- Always look out for pedestrians when your vehicle is maintaining a distance with the vehicle ahead.

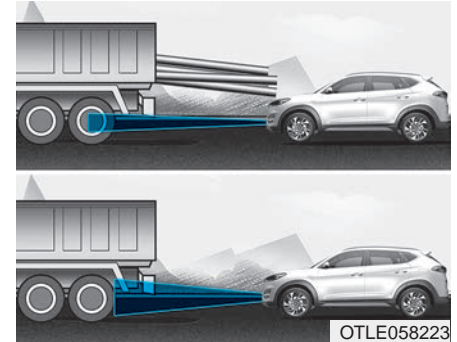

- Always be cautious for vehicles with higher height or vehicles carrying loads that sticks out from the back of the vehicle.

## **WARNING**

When using the Smart Cruise Control take the following precautions:

- If an emergency stop is necessary, you must apply the brakes. The vehicle cannot be stopped at every emergency situation by using the Smart Cruise Control system.
- Keep a safe distance according to road conditions and vehicle speed. If the vehicle to vehicle distance is too close during a high-speed driving, a serious collision may result.
- Always maintain sufficient braking distance and decelerate your vehicle by applying the brakes if necessary.
- The Smart Cruise Control system cannot recognize a stopped vehicle, pedestrians or an oncoming vehicle. Always look ahead cautiously to prevent unexpected and sudden situations from occurring.

(Continued)

(Continued)

- Vehicles moving in front of you with a frequent lane change may cause a delay in the system's reaction or may cause the system to react to a vehicle actually in an adjacent lane. Always drive cautiously to prevent unexpected and sudden situations from occurring.
- Always be aware of the selected speed and vehicle to vehicle distance. The driver should not solely rely on the system but always pay attention to driving conditions and control your vehicle speed.
- The Smart Cruise Control system may not recognize complex driving situations so always pay attention to driving conditions and control your vehicle speed.

## **NOTICE**

The Smart Cruise Control system may not operate temporarily due to:

- Electrical interference
- Modifying the suspension
- Differences of tire abrasion or tire pressure
- Installing different type of tires

## SPECIAL DRIVING CONDITIONS

### Hazardous driving conditions

When hazardous driving elements are encountered such as water, snow, ice, mud and sand, take the bellow suggestions:

- Drive cautiously and keep a longer braking distance.
- Avoid abrupt braking or steering.
- When your vehicle is stuck in snow, mud, or sand, use the second gear. Accelerate slowly to avoid unnecessary wheel spinning.
- Put sand, rock salt, tire chains or other non-slip materials under the wheels to provide additional traction while being stuck in ice, snow, or mud.

#### WARNING

**Downshifting with an automatic transaxle while driving on slippery surfaces can cause an accident. The sudden change in tire speed could cause the tires to skid. Be careful when downshifting on slippery surfaces.**

### Rocking the vehicle

If it is necessary to rock the vehicle to free it from snow, sand, or mud, first turn the steering wheel right and left to clear the area around your front wheels. Then, shift back and forth between R (Reverse) and a forward gear.

Try to avoid spinning the wheels, and do not race the engine.

To prevent transaxle wear, wait until the wheels stop spinning before shifting gears. Release the accelerator pedal while shifting, and press lightly on the accelerator pedal while the transaxle is in gear. Slowly spinning the wheels in forward and reverse directions causes a rocking motion that may free the vehicle.

#### WARNING

**If the tires spin at high speed the tires can explode, and you or others may be injured. Do not attempt this procedure if people or objects are anywhere near the vehicle.**

**The vehicle can overheat causing an engine compartment fire or other damage. Spin the wheels as little as possible and avoid spinning the wheels at speeds over 56 km/h (35 mph) as indicated on the speedometer.**

## **i** Information

The ESC system (if equipped) must be turned OFF before rocking the vehicle.

### **NOTICE**

If you are still stuck after rocking the vehicle a few times, have the vehicle pulled out by a tow vehicle to avoid engine overheating, possible damage to the transaxle, and tire damage. See "Towing" in chapter 6.

## Smooth cornering

Avoid braking or gear changing in corners, especially when roads are wet. Ideally, corners should always be taken under gentle acceleration.

## Driving at night

Night driving presents more hazards than driving in the daylight. Here are some important tips to remember:

- Slow down and keep more distance between you and other vehicles, as it may be more difficult to see at night, especially in areas where there may not be any street lights.
- Adjust your mirrors to reduce the glare from other driver's headlamps.
- Keep your headlamps clean and properly aimed. Dirty or improperly aimed headlamps will make it much more difficult to see at night.
- Avoid staring directly at the headlamps of oncoming vehicles. You could be temporarily blinded, and it will take several seconds for your eyes to readjust to the darkness.

## Driving in the rain

Rain and wet roads can make driving dangerous. Here are a few things to consider when driving in the rain or on slick pavement:

- Slow down and allow extra following distance. A heavy rainfall makes it harder to see and increases the distance needed to stop your vehicle.
- Turn OFF your Cruise Control. (if equipped)
- Replace your windshield wiper blades when they show signs of streaking or missing areas on the windshield.
- Be sure your tires have enough tread. If your tires do not have enough tread, making a quick stop on wet pavement can cause a skid and possibly lead to an accident. **See "Tire Replacement" in chapter 7.**
- Turn on your headlamps to make it easier for others to see you.
- Driving too fast through large puddles can affect your brakes. If you must go through puddles, try to drive through them slowly.

- If you believe your brakes may be wet, apply them lightly while driving until normal braking operation returns.

### ***Hydroplaning***

If the road is wet enough and you are going fast enough, your vehicle may have little or no contact with the road surface and actually ride on the water. The best advice is SLOW DOWN when the road is wet.

**The risk of hydroplaning increases as the depth of tire tread decreases, refer to "Tire Replacement" in chapter 7.**

### **Driving in flooded areas**

Avoid driving through flooded areas unless you are sure the water is no higher than the bottom of the wheel hub. Drive through any water slowly. Allow adequate stopping distance because brake performance may be reduced.

After driving through water, dry the brakes by gently applying them several times while the vehicle is moving slowly.

### **Highway driving**

#### ***Tires***

Adjust the tire inflation, as specified. Under-inflation may overheat or damage the tires.

Do not install worn-out or damaged tires, which may reduce traction or fail the braking operation.

#### **Information**

**Never over-inflate your tires above the maximum inflation pressure, as specified on your tires.**

#### ***Fuel, engine coolant and engine oil***

Driving at a high speed consumes more fuel than driving at a slow speed, such as in an urban area. Do not forget to check both the engine coolant and engine oil.

#### ***Drive belt***

A loose or damaged drive belt may overheat the engine.

## Reducing the risk of a rollover

Your multi-purpose passenger vehicle is defined as a Sports Utility Vehicle (SUV). SUV's have higher ground clearance and a narrower track to make them capable of performing in a wide variety of off-road applications. The specific design characteristics give them a higher center of gravity than ordinary vehicles making them more likely to roll over if you make abrupt turns. Utility vehicles have a significantly higher rollover rate than other types of vehicles. Due to this risk, driver and passengers are strongly recommended to buckle their seat belts. In a rollover crash, an unbelted person is significantly more likely to die than a person wearing a seat belt.

There are steps that a driver can make to reduce the risk of a rollover. If at all possible, avoid sharp turns or abrupt maneuvers, do not load your vehicle with heavy cargo on the roof, and never modify your vehicle in any way.

### WARNING

**Utility vehicles have a significantly higher rollover rate than other types of vehicles. To prevent rollovers or loss of control:**

- **Take corners at slower speeds than you would with a passenger vehicle.**
- **Avoid sharp turns and abrupt maneuvers.**
- **Do not modify your vehicle in any way that you would raise the center of gravity.**
- **Keep tires properly inflated.**
- **Do not carry heavy cargo on the roof.**

### WARNING

**In a rollover crash, an unbelted person is significantly more likely to die than a person wearing a seat belt. Make sure all passengers are wearing their seat belts.**

## WINTER DRIVING

The severe weather conditions of winter quickly wear out tires and cause other problems. To minimize winter driving problems, you should take the following suggestions:

### Information

**Snow tires and tire chains for the national language (Bulgarian, Hungarian, Icelandic, Polish) see the Appendix, chapter I.**

### Snow or icy conditions

You need to keep sufficient distance between your vehicle and the vehicle in front of you.

Apply the brakes gently. Speeding, rapid acceleration, sudden brake applications, and sharp turns are potentially very hazardous practices. During deceleration, use engine braking to the fullest extent. Sudden brake applications on snowy or icy roads may cause skids to occur.

To drive your vehicle in deep snow, it may be necessary to use snow tires or to install tire chains on your tires.

Always carry emergency equipment. Some of the items you may want to carry include tire chains, tow straps or chains, a flashlight, emergency flares, sand, a shovel, jumper cables, a window scraper, gloves, ground cloth, coveralls, a blanket, etc.

### Snow tires

#### WARNING

**Snow tires should be equivalent in size and type to the vehicle's standard tires. Otherwise, the safety and handling of your vehicle may be adversely affected.**

If you mount snow tires on your vehicle, make sure to use radial tires of the same size and load range as the original tires. Mount snow tires on all four wheels to balance your vehicle's handling in all weather conditions. The traction provided by snow tires on dry roads may not be as high as your vehicle's original equipment tires. Check with the tire dealer for maximum speed recommendations.

### Information

**Do not install studded tires without first checking local and municipal regulations for possible restrictions against their use.**



## Tire chains



OTLE058036

Since the sidewalls of radial tires are thinner than other types of tires, they may be damaged by mounting some types of tire chains on them. Therefore, the use of snow tires is recommended instead of tire chains. Do not mount tire chains on vehicles equipped with aluminum wheels; if unavoidable use a wire type chain. If tire chains must be used, use genuine HYUNDAI parts and install the tire chain after reviewing the instructions provided with the tire chains. Damage to your vehicle caused by improper tire chain use is not covered by your vehicle manufacturer's warranty.

### **WARNING**

The use of tire chains may adversely affect vehicle handling:

- Drive less than 30 km/h (20 mph) or the chain manufacturer's recommended speed limit, whichever is lower.
- Drive carefully and avoid bumps, holes, sharp turns, and other road hazards, which may cause the vehicle to bounce.
- Avoid sharp turns or locked wheel braking.

### **Information**

- Install tire chains on the front tires. It should be noted that installing tire chains on the tires will provide a greater driving force, but will not prevent side skids.
- Do not install studded tires without first checking local and municipal regulations for possible restrictions against their use.

### Chain Installation

When installing tire chains, follow the manufacturer's instructions and mount them as tightly possible. Drive slowly (less than 30 km/h (20 mph)) with chains installed. If you hear the chains contacting the body or chassis, stop and tighten them. If they still make contact, slow down until the noise stops. Remove the tire chains as soon as you begin driving on cleared roads.

When mounting snow chains, park the vehicle on level ground away from traffic. Turn on the vehicle Hazard Warning Flasher and place a triangular emergency warning device behind the vehicle (if available). Always place the vehicle in P (Park), apply the parking brake and turn off the engine before installing snow chains.

### NOTICE

When using tire chains:

- **Wrong size chains or improperly installed chains can damage your vehicle's brake lines, suspension, body and wheels.**
- **Use SAE "S" class or wire chains.**
- **If you hear noise caused by chains contacting the body, retighten the chain to prevent contact with the vehicle body.**
- **To prevent body damage, retighten the chains after driving 0.5~1.0 km (0.3~0.6 miles).**
- **Do not use tire chains on vehicles equipped with aluminum wheels. If unavoidable, use a wire type chain.**
- **Use wire chains less than 15 mm (0.59 in) wide to prevent damage to the chain's connection.**

### Winter Precautions

#### Use high quality ethylene glycol coolant

Your vehicle is delivered with high quality ethylene glycol coolant in the cooling system. It is the only type of coolant that should be used because it helps prevent corrosion in the cooling system, lubricates the water pump and prevents freezing. Be sure to replace or replenish your coolant in accordance with the maintenance schedule in section 7. Before winter, have your coolant tested to assure that its freezing point is sufficient for the temperatures anticipated during the winter.

### **Check battery and cables**

The winter temperature increases the battery consumption. **Inspect the battery and cables, as specified in the chapter 7.** The battery charging level can be checked by an authorized HYUNDAI dealer or in a service station.

### **Change to "winter weight" oil if necessary**

In some regions during winter, it is recommended to use the "winter weight" oil with lower viscosity. For further information, refer to the chapter 8. When you are not sure about a type of winter weight oil, consult an authorized HYUNDAI dealer.

### **Check spark plugs and ignition system**

**Inspect the spark plugs, as specified in the chapter 7.** If necessary, replace them. Also check all ignition wirings and components for any cracks, wear-out, and damage.

### **To prevent locks from freezing**

To prevent the locks from being frozen, spray approved de-icing fluid or glycerin into key holes. When a lock opening is already covered with ice, spray approved de-icing fluid over the ice to remove it. When an internal part of a lock freezes, try to thaw it with a heated key. Carefully use the heated key to avoid an injury.

### **Use approved window washer anti-freeze solution in system**

To prevent the window washer from being frozen, add authorized window washer anti-freeze solution, as specified on the window washer container. Window washer anti-freeze solution is available from an authorized HYUNDAI dealer, and so are the most vehicle accessory outlets. Do not use engine coolant or other types of anti-freeze solution to prevent any damage to the vehicle paint.

### **Do not let your parking brake freeze**

Under some conditions your parking brake can freeze in the engaged position. This is most likely to happen when there is an accumulation of snow or ice around or near the rear brakes or if the brakes are wet. When there is the risk that your parking brake may freeze, temporarily apply it with the shift lever in P (Park). Also, block the rear wheels in advance, so the vehicle may not roll. Then, release the parking brake.

### **Do not let ice and snow accumulate underneath**

Under some conditions, snow and ice can build up under the fenders and interfere with the steering. When driving in such conditions during the severe winter, you should check underneath the vehicle on a regular basis, so that moving the front wheels and the steering components is unblocked.

### **Carry emergency equipment**

In accordance with weather conditions, you should carry appropriate emergency equipment, while driving. Some of the items you may want to carry include tire chains, tow straps or chains, flashlight, emergency flares, sand, shovel, jumper cables, window scraper, gloves, ground cloth, coveralls, blanket, etc.

### **Do not place objects or materials in the engine compartment**

Putting objects or materials in the engine compartment may cause an engine failure or combustion, because those may block the engine cooling. Such damage will not be covered by the manufacturer's warranty.

## TRAILER TOWING (FOR EUROPE)

If you are considering to tow with your vehicle, you should first check with your country's Department of Motor Vehicles to determine legal requirements. Since laws vary the requirements for towing trailers, cars, or other types of vehicles or apparatus may differ. Ask an authorized HYUNDAI dealer for further details before towing.

Remember that trailering is different than just driving your vehicle by itself. Trailering means changes in handling, durability, and fuel economy. Successful, safe trailering requires correct equipment, and it has to be used properly. Damage to your vehicle caused by improper trailer towing is not covered by your vehicle manufacturer's warranty.

This section contains many time-tested, important trailering tips and safety rules. Many of these are important for your safety and that of your passengers. Please read this section carefully before you pull a trailer.

### WARNING

#### Take the following precautions:

- If you don't use the correct equipment and/or drive improperly, you can lose control of the vehicle when you are pulling a trailer. For example, if the trailer is too heavy, the braking performance may be reduced. You and your passengers could be seriously or fatally injured. Pull a trailer only if you have followed all the steps in this section.
- Before towing, make sure the total trailer weight, GCW (Gross Combination Weight), GVW (Gross Vehicle Weight), GAW (Gross Axle Weight) and trailer tongue load are all within the limits.
- When you tow a trailer, make sure to turn off the ISG system.

### **i** Information - For Europe

- **The technically permissible maximum load on the rear axle(s) may be exceeded by not more than 15 % and the technically permissible maximum laden mass of the vehicle may be exceeded by not more than 10% or 100 kg (220.4 lbs), whichever value is lower. In this case, do not exceed 100 km/h (62.1 mph) for vehicle of category M1 or 80 km/h (49.7 mph) for vehicle of category N1.**
- **When a vehicle of category M1 is towing a trailer, the additional load imposed at the trailer coupling device may cause the tire maximum load ratings to be exceeded, but not by more than 15%. In this case, do not exceed 100 km/h (62.1 mph) and increase the tire inflation pressure by at least 0.2 bar.**

### **If you decide to pull a trailer?**

Here are some important points if you decide to pull a trailer:

- Consider using a sway control. You can ask a trailer hitch dealer about sway control.
  - Do not do any towing with your vehicle during its first 2,000 km (1,200 miles) in order to allow the engine to properly break in. Failure to heed this caution may result in serious engine or transaxle damage.
  - When towing a trailer, be sure to consult an authorized HYUNDAI dealer for further information on additional requirements such as a towing kit, etc.
  - Always drive your vehicle at a moderate speed (less than 100 km/h (60 mph)) or posted towing speed limit.
- On a long uphill grade, do not exceed 70 km/h (45 mph) or the posted towing speed limit, whichever is lower.
  - Carefully observe the weight and load limits provided in the following pages.

## Trailer weight

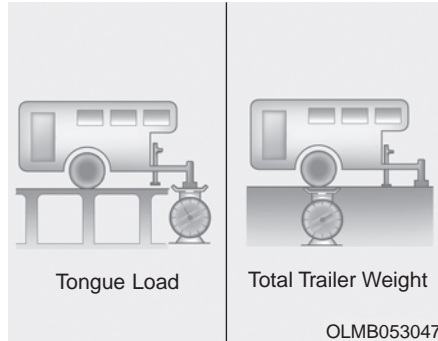

What is the maximum safe weight of a trailer? It should never weigh more than the maximum trailer weight with trailer brakes. But even that can be too heavy. It depends on how you plan to use your trailer. For example, speed, altitude, road grades, outside temperature and how often your vehicle is used to pull a trailer are all important. The ideal trailer weight can also depend on any special equipment that you have on your vehicle.

## Tongue load

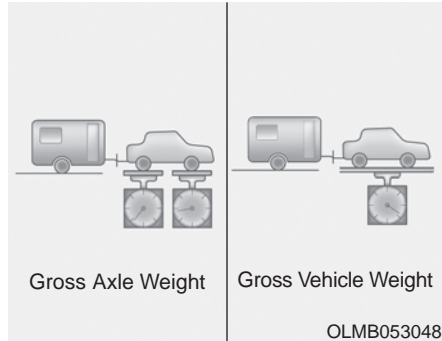

The tongue load is an important weight to measure because it affects the total Gross Vehicle Weight (GVW) of your vehicle. The trailer tongue should weigh a maximum of 10% of the total loaded trailer weight, within the limits of the maximum trailer tongue load permissible.

After you've loaded your trailer, weigh the trailer and then the tongue, separately, to see if the weights are proper. If they aren't, you may be able to correct them simply by moving some items around in the trailer.

## WARNING

Take the following precautions:

- Never load a trailer with more weight in the rear than in the front. The front should be loaded with approximately 60% of the total trailer load; the rear should be loaded with approximately 40% of the total trailer load.
- Never exceed the maximum weight limits of the trailer or trailer towing equipment. Improper loading can result in damage to your vehicle and/or personal injury. Check weights and loading at a commercial scale or highway patrol office equipped with scales.

**Reference weight and distance when towing a trailer**

Item		Gasoline Engine									
		1.6 GDI	2.0 MPI				2.4 GDI	1.6 T-GDI			
		2WD	2WD		4WD		4WD	2WD		4WD	
		M/T	M/T	A/T	M/T	A/T	A/T	M/T	DCT	M/T	DCT
Maximum trailer weight kg (lbs.)	Without brake System	650 (1,433)	750 (1,653)	750 (1,653)	750 (1,653)	750 (1,653)	750 (1,653)	750 (1,653)	750 (1,653)	750 (1,653)	750 (1,653)
	With brake System	1,400 (3,086)	1,900 (4,189)	1,600 (3,527)	1,900 (4,189)	1,600 (3,527)	1,500 (3,307)	1,900 (4,189)	1,600 (3,527)	1,900 (4,189)	1,600 (3,527)
Maximum permissible static vertical load on the coupling device kg (lbs.)		100 (220)									
Recommended distance from rear wheel center to coupling point mm (inch)		1,000 (39.37)									

M/T : Manual transaxle, A/T : Automatic transaxle, DCT : Dual clutch transmission



Item		Diesel engine													
		1.6 TCI (Low)	1.6 TCI (High)				1.6 TCI (48V MHEV)				2.0 TCI (High)		2.0 TCI (48V MHEV)		
		2WD	2WD		4WD		2WD		4WD		4WD		4WD		
		M/T	M/T	DCT	M/T	DCT	M/T	DCT	M/T	DCT	M/T	A/T	M/T	A/T	
Maximum trailer weight kg (lbs.)	Without brake System	750 (1,653)	750 (1,653)	750 (1,653)	750 (1,653)	750 (1,653)	750 (1,653)	750 (1,653)	750 (1,653)	750 (1,653)	750 (1,653)	750 (1,653)	750 (1,653)	750 (1,653)	
	With brake System	1,400 (3,086)	1,400 (3,086)	1,600 (3,527)	1,400 (3,086)	1,600 (3,527)	1,400 (3,086)	1,600 (3,527)	1,400 (3,086)	1,600 (3,527)	2,200 (4,850)	1,900 (4,189)	2,200 (4,850)	1,900 (4,189)	
Maximum permissible static vertical load on the coupling device kg (lbs.)		100 (220)													
Recommended distance from rear wheel center to coupling point mm (inch)		1,000 (39.37)													

M/T : Manual transaxle, A/T : Automatic transaxle, DCT : Dual clutch transmission

### Trailer towing equipment

#### Hitches



#### **i** Information

The mounting hole for hitches are located on both sides of the underbody behind the rear tires.

It's important to have the correct hitch equipment. Crosswinds, large trucks going by, and rough roads are a few reasons why you'll need the right hitch. Here are some rules to follow:

- Do you have to make any holes in the body of your vehicle when you install a trailer hitch? If you do, then be sure to seal the holes later when you remove the hitch. If you don't seal them, carbon monoxide (CO) from your exhaust can get into your vehicle, as well as dirt and water.
- The bumpers on your vehicle are not intended for hitches. Do not attach rental hitches or other bumper-type hitches to them. Use only a frame-mounted hitch that does not attach to the bumper.
- A HYUNDAI trailer hitch accessory is available at an authorized HYUNDAI dealer.

#### **Safety chains**

You should always attach chains between your vehicle and your trailer. Cross the safety chains under the tongue of the trailer so that the tongue will not drop to the road if it becomes separated from the hitch. Instructions about safety chains may be provided by the hitch manufacturer or trailer manufacturer. Follow the manufacturer's recommendation for attaching safety chains. Always leave just enough slack so you can turn with your trailer. And, never allow safety chains to drag on the ground.

### **Trailer brakes**

If your trailer is equipped with a braking system, make sure it conforms your country's regulations and that it is properly installed and operating correctly.

If your trailer weighs more than the maximum trailer weight without trailer brakes loaded, then it needs its own brakes and they must be adequate. Be sure to read and follow the instructions for the trailer brakes so you'll be able to install, adjust and maintain them properly. Be sure not to tap into your vehicle's brake system.

#### **WARNING**

**Do not use a trailer with its own brakes unless you are absolutely certain that you have properly set up the brake system. This is not a task for amateurs. Use an experienced, competent trailer shop for this work.**

### **Driving with a trailer**

Towing a trailer requires a certain amount of experience. Before setting out for the open road, you must get to know your trailer. Acquaint yourself with the feel of handling and braking with the added weight of the trailer. And always keep in mind that the vehicle you are driving is now longer and not nearly as responsive as your vehicle is by itself.

Before you start, check the trailer hitch and platform, safety chains, electrical connector(s), lights, tires and brakes.

During your trip, occasionally check to be sure that the load is secure, and that the lights and trailer brakes are still working.

### **Distance**

Stay at least twice as far behind the vehicle ahead as you would when driving your vehicle without a trailer. This can help you avoid situations that require heavy braking and sudden turns.

### **Passing**

You will need more passing distance up ahead when you're towing a trailer. And, because of the increased vehicle length, you'll need to go much farther beyond the passed vehicle before you can return to your lane.

### ***Backing up***

Hold the bottom of the steering wheel with one hand. Then, to move the trailer to the left, move your hand to the left. To move the trailer to the right, move your hand to the right. Always back up slowly and, if possible, have someone guide you.

### ***Making turns***

When you're turning with a trailer, make wider turns than normal. Do this so your trailer won't strike soft shoulders, curbs, road signs, trees, or other objects. Avoid jerky or sudden maneuvers. Signal well in advance.

### ***Turn signals***

When you tow a trailer, your vehicle has to have a different turn signal flasher and extra wiring. The green arrows on your instrument panel will flash whenever you signal a turn or lane change. Properly connected, the trailer lights will also flash to alert other drivers you're about to turn, change lanes, or stop.

When towing a trailer, the green arrows on your instrument panel will flash for turns even if the bulbs on the trailer are burned out. Thus, you may think drivers behind you are seeing your signals when, in fact, they are not. It's important to check occasionally to be sure the trailer bulbs are still working. You must also check the lights every time you disconnect and then reconnect the wires.

### **WARNING**

**Do not connect a trailer lighting system directly to your vehicle's lighting system. Use an approved trailer wiring harness. Failure to do so could result in damage to the vehicle electrical system and/or personal injury. Consult an authorized HYUNDAI dealer for assistance.**

## **Driving on hills**

Reduce speed and shift to a lower gear before you start down a long or steep downgrade. If you don't shift down, you might have to use your brakes so much that they would get overheated and may not operate efficiently.

On a long uphill grade, shift down and reduce your speed to around 70 km/h (45 mph) to reduce the possibility of engine and transaxle overheating.

If your trailer weighs more than the maximum trailer weight without trailer brakes and you have an automatic transaxle/dual clutch transmission, you should drive in D (Drive) when towing a trailer.

Operating your vehicle in D (Drive) when towing a trailer will minimize heat build-up and extend the life of your transaxle.

### **NOTICE**

**To prevent engine and/or transaxle overheating:**

- **When towing a trailer on steep grades (in excess of 6%) pay close attention to the engine coolant temperature gauge to ensure the engine does not overheat. If the needle of the coolant temperature gauge moves towards "H" (HOT), pull over and stop as soon as it is safe to do so, and allow the engine to idle until it cools down. You may proceed once the engine has cooled sufficiently.**
- **You must decide your vehicle speed according to trailer weight and uphill grade.**
- **Vehicles equipped with a dual clutch transmission when towing a trailer on steep grades, the clutch in the transmission could overheat.**

**(Continued)**

**(Continued)**

**When the clutch is overheated, the safe protection mode engages. If the safe protection mode engages, the gear position indicator on the cluster blinks with a chime sound.**

**At this time, a warning message will appear on the LCD display and driving may not be smooth.**

**If you ignore this warning, the driving condition may become worse.**

**To return to normal driving condition, stop the vehicle on a flat road and apply the foot brake for a few minutes before driving off.**

### **Parking on hills**

Generally, if you have a trailer attached to your vehicle, you should not park your vehicle on a hill.

However, if you ever have to park your trailer on a hill, here's how to do it:

1. Pull the vehicle into the parking space.  
Turn the steering wheel in the direction of the curb (right if headed down hill, left if headed up hill).
2. Shift the vehicle to P (Park, for automatic transaxle/dual clutch transmission vehicle) or neutral (for manual transaxle vehicle).
3. Set the parking brake and shut off the vehicle.
4. Place wheel chocks under the trailer wheels on the down hill side of the wheels.
5. Start the vehicle, hold the brakes, shift to neutral, release the parking brake and slowly release the brakes until the trailer chocks absorb the load.

6. Reapply the brakes and parking brakes.
7. Move the shift lever to P (Park, for automatic transaxle/dual clutch transmission vehicle) or 1st gear when the vehicle is parked on an uphill grade and in R (Reverse) on a downhill (for manual transaxle vehicle).
8. Shut off the vehicle and release the vehicle brakes but leave the parking brake set.

### **WARNING**

**To prevent serious or fatal injury:**

- **Do not get out of the vehicle without the parking brake firmly set. If you have left the engine running, the vehicle can move suddenly. You and others could be seriously or fatally injured.**
- **Do not apply the accelerator pedal to hold the vehicle on an uphill.**

### **Ready to leave after parking on a hill**

1. With the shift lever to P (Park, for automatic transaxle/dual clutch transmission vehicle) or neutral (for manual transaxle vehicle), apply your brakes and hold the brake pedal down while you:
  - Start your engine;
  - Shift into gear; and
  - Release the parking brake.
2. Slowly remove your foot from the brake pedal.
3. Drive slowly until the trailer is clear of the chocks.
4. Stop and have someone pick up and store the chocks.

## Maintenance when towing a trailer

Your vehicle will need service more often when you regularly pull a trailer. Important items to pay particular attention to include engine oil, automatic transaxle fluid, axle lubricant and cooling system fluid. Brake condition is another important item to frequently check. If you're trailering, it's a good idea to review these items before you start your trip. Don't forget to also maintain your trailer and hitch. Follow the maintenance schedule that accompanied your trailer and check it periodically. Preferably, conduct the check at the start of each day's driving. Most importantly, all hitch nuts and bolts should be tight.

### **NOTICE**

To prevent vehicle damage:

- **Due to higher load during trailer usage, overheating might occur on hot days or during uphill driving. If the coolant gauge indicates over-heating, switch off the air conditioner and stop the vehicle in a safe area to cool down the engine.**
- **When towing check automatic transaxle fluid more frequently.**
- **If your vehicle is not equipped with an air conditioner, you should install a condenser fan to improve engine performance when towing a trailer.**

### VEHICLE WEIGHT

Two labels on your driver's door sill show how much weight your vehicle was designed to carry: the Tire and Loading Information Label and the Certification Label.

Before loading your vehicle, familiarize yourself with the following terms for determining your vehicle's weight ratings, from the vehicle's specifications and the Certification Label:

#### Base Curb Weight

This is the weight of the vehicle including a full tank of fuel and all standard equipment. It does not include passengers, cargo, or optional equipment.

#### Vehicle Curb Weight

This is the weight of your new vehicle when you picked it up from your dealer plus any aftermarket equipment.

#### Cargo Weight

This figure includes all weight added to the Base Curb Weight, including cargo and optional equipment.

#### GAW (Gross Axle Weight)

This is the total weight placed on each axle (front and rear) - including vehicle curb weight and all payload.

#### GAWR (Gross Axle Weight Rating)

This is the maximum allowable weight that can be carried by a single axle (front or rear). These numbers are shown on the Certification Label. The total load on each axle must never exceed its GAWR.

#### GVW (Gross Vehicle Weight)

This is the Base Curb Weight plus actual Cargo Weight plus passengers.

#### GVWR (Gross Vehicle Weight Rating)

This is the maximum allowable weight of the fully loaded vehicle (including all options, equipment, passengers and cargo). The GVWR is shown on the Certification Label located on the driver's door sill.

### Overloading

#### WARNING

**The Gross Axle Weight Rating (GAWR) and the Gross Vehicle Weight Rating (GVWR) for your vehicle are on the Certification Label attached to the driver's (or front passenger's) door. Exceeding these ratings can cause an accident or vehicle damage. You can calculate the weight of your load by weighing the items (and people) before putting them in the vehicle. Be careful not to overload your vehicle.**



# What to do in an emergency

Hazard warning flasher .....	6-2
In case of an emergency while driving .....	6-2
If the engine stalls while driving .....	6-2
If the engine stalls at a crossroad or crossing .....	6-3
If you have a flat tire while driving .....	6-3
<b>If the engine will not start .....</b>	<b>6-4</b>
If the engine doesn't turn over or turns over slowly .....	6-4
If the engine turns over normally but doesn't start .....	6-4
<b>Jump starting .....</b>	<b>6-4</b>
<b>If the engine overheats .....</b>	<b>6-8</b>
<b>Tire Pressure Monitoring System (TPMS).....</b>	<b>6-10</b>
Check tire pressure .....	6-10
Tire pressure monitoring system .....	6-11
Low tire pressure telltale .....	6-12
Low tire pressure position telltale and tire pressure telltale .....	6-12
TPMS (Tire Pressure Monitoring System) malfunction indicator .....	6-13
Changing a tire with TPMS.....	6-14
<b>If you have a flat tire (with spare tire).....</b>	<b>6-17</b>
Jack and tools .....	6-17
Changing tires .....	6-18
Jack label.....	6-23
EC Declaration of conformity for Jack.....	6-24
<b>If you have a flat tire (with Tire Mobility Kit)</b>	
- <b>Type A .....</b>	<b>6-25</b>
Introduction .....	6-25
Notes on the safe use of the Tire Mobility Kit.....	6-26
Components of the Tire Mobility Kit .....	6-27
Using the Tire Mobility Kit.....	6-28
Distributing the sealant .....	6-30
Checking the tire inflation pressure .....	6-30
<b>If you have a flat tire (with Tire Mobility Kit)</b>	
- <b>Type B .....</b>	<b>6-32</b>
Introduction .....	6-32
Notes on the safe use of the Tire Mobility Kit.....	6-33
Components of the Tire Mobility Kit .....	6-34
Using the Tire Mobility Kit.....	6-35
Distributing the sealant .....	6-37
Checking the tire inflation pressure .....	6-37
<b>Towing .....</b>	<b>6-39</b>
Towing service .....	6-39
Removable towing hook .....	6-40
Emergency towing .....	6-41
<b>Emergency commodity.....</b>	<b>6-43</b>
Fire extinguisher .....	6-43
First aid kit .....	6-43
Triangle reflector .....	6-43
Tire pressure gauge .....	6-43

### HAZARD WARNING FLASHER

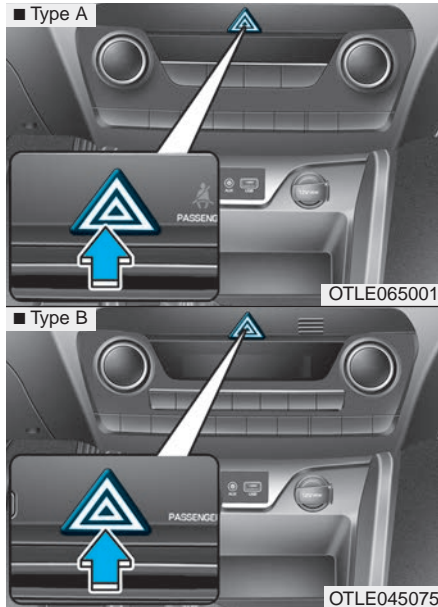

The hazard warning flasher serves as a warning to other drivers to exercise extreme caution when approaching, overtaking, or passing your vehicle.

It should be used whenever emergency repairs are being made or when the vehicle is stopped near the edge of a roadway.

To turn the hazard warning flasher on or off, press the hazard warning flasher button with the Engine Start/Stop button in any position. The button is located in the center fascia panel. All turn signal lights will flash simultaneously.

- The hazard warning flasher operates whether your vehicle is running or not.
- The turn signals do not work when the hazard flasher is on.

### IN CASE OF AN EMERGENCY WHILE DRIVING

#### If the engine stalls while driving

- Reduce your speed gradually, keeping a straight line. Move cautiously off the road to a safe place.
- Turn on your hazard warning flasher.
- Try to start the engine again. If your vehicle will not start, we recommend that you contact an authorized HYUNDAI dealer.

### If the engine stalls at a cross-road or crossing

If the engine stalls at a crossroad or crossing, if safe to do so, move the shift lever to the N (Neutral) position and then push the vehicle to a safe location.

### If you have a flat tire while driving

If a tire goes flat while you are driving:

- Take your foot off the accelerator pedal and let the vehicle slow down while driving straight ahead. Do not apply the brakes immediately or attempt to pull off the road as this may cause loss of vehicle control resulting in an accident. When the vehicle has slowed to such a speed that it is safe to do so, brake carefully and pull off the road. Drive off the road as far as possible and park on firm, level ground. If you are on a divided highway, do not park in the median area between the two traffic lanes.

- When the vehicle is stopped, press the hazard warning flasher button, move the shift lever into P (Park, for automatic transaxle/dual clutch transmission vehicle) or neutral (for manual transaxle vehicle), apply the parking brake, and place the ignition switch in the LOCK/OFF position.
- Have all passengers get out of the vehicle. Be sure they all get out on the side of the vehicle that is away from traffic.
- When changing a flat tire, follow the instructions provided later in this chapter.

## IF THE ENGINE WILL NOT START

### If the engine doesn't turn over or turns over slowly

- Be sure the shift lever is in N (Neutral) or P (Park) if it is an automatic transaxle/dual clutch transmission vehicle. The engine starts only when the shift lever is in N (Neutral) or P (Park).
- Check the battery connections to be sure they are clean and tight.
- Turn on the interior light. If the light dims or goes out when you operate the starter, the battery is drained.

Do not push or pull the vehicle to start it. This could cause damage to your vehicle. **See instructions for "Jump Starting" provided in this chapter.**

### CAUTION

**Push or pull starting the vehicle may cause the catalytic converter to overload which can lead to damage to the emission control system.**

## JUMP STARTING

Jump starting can be dangerous if done incorrectly. Follow the jump starting procedure in this section to avoid serious injury or damage to your vehicle. If in doubt about how to properly jump start your vehicle, we strongly recommend that you have a service technician or towing service do it for you.

### If the engine turns over normally but doesn't start

- Check the fuel level and add fuel if necessary.

If the engine still does not start, we recommend that you call an authorized HYUNDAI dealer for assistance.

## WARNING

To prevent **SERIOUS INJURY** or **DEATH** to you or bystanders, always follow these precautions when working near or handling the battery:



Always read and follow instructions carefully when handling a battery.



Wear eye protection designed to protect the eyes from acid splashes.



Keep all flames, sparks, or smoking materials away from the battery.



Hydrogen is always present in battery cells, is highly combustible, and may explode if ignited.



Keep batteries out of reach of children.

(Continued)

(Continued)



Batteries contain sulfuric acid which is highly corrosive. Do not allow acid to contact your eyes, skin or clothing.

If acid gets into your eyes, flush your eyes with clean water for at least 15 minutes and get immediate medical attention. If acid gets on your skin, thoroughly wash the area. If you feel pain or a burning sensation, get medical attention immediately.

- When lifting a plastic-cased battery, excessive pressure on the case may cause battery acid to leak. Lift with a battery carrier or with your hands on opposite corners.
- Do not attempt to jump start your vehicle if your battery is frozen.

(Continued)

(Continued)

- **NEVER** attempt to recharge the battery when the vehicle's battery cables are connected to the battery.
- The electrical ignition system works with high voltage. **NEVER** touch these components with the engine running or when the Engine Start/Stop button is in the ON position.
- Do not allow the (+) and (-) jumper cables to touch. It may cause sparks.
- The battery may rupture or explode when you jump start with a low or frozen battery.

### NOTICE

To prevent damage to your vehicle:

- Only use a 12-volt power supply (battery or jumper system) to jump start your vehicle.
- Do not attempt to jump start your vehicle by push-starting.

### **i** Information



An inappropriately disposed battery can be harmful to the environment and human health. Dispose the battery according to your local law(s) or regulations.

### ***Jump starting procedure***

1. Position the vehicles close enough that the jumper cables will reach, but do not allow the vehicles to touch.
2. Avoid fans or any moving parts in the engine compartment at all times, even when the vehicles are turned off.
3. Turn off all electrical devices such as radios, lights, air conditioning, etc. Put the vehicles in P (Park, for automatic transaxle/dual clutch transmission vehicle) or neutral (for manual transaxle vehicle), and set the parking brakes. Turn both vehicles OFF.

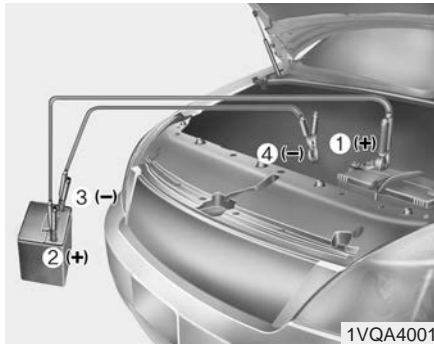

4. Connect the jumper cables in the exact sequence shown in the illustration. First connect one jumper cable to the red, positive (+) jumper terminal of your vehicle (1).
5. Connect the other end of the jumper cable to the red, positive (+) battery/jumper terminal of the assisting vehicle (2).
6. Connect the second jumper cable to the black, negative (-) battery/chassis ground of the assisting vehicle (3).

7. Connect the other end of the second jumper cable to the black, negative (-) chassis ground of your vehicle (4).

Do not allow the jumper cables to contact anything except the correct battery or jumper terminals or the correct ground. Do not lean over the battery when making connections.

8. Start the engine of the assisting vehicle and let it run at approximately 2,000 rpm for a few minutes. Then start your vehicle.

If your vehicle will not start after a few attempts, it probably requires servicing. In this event please seek qualified assistance. If the cause of your battery discharging is not apparent, have your vehicle checked by an authorized HYUNDAI dealer.

Disconnect the jumper cables in the exact reverse order you connected them:

1. Disconnect the jumper cable from the black, negative (-) chassis ground of your vehicle (4).
2. Disconnect the other end of the jumper cable from the black, negative (-) battery/chassis ground of the assisting vehicle (3).
3. Disconnect the second jumper cable from the red, positive (+) battery/jumper terminal of the assisting vehicle (2).
4. Disconnect the other end of the jumper cable from the red, positive (+) jumper terminal of your vehicle (1).

## IF THE ENGINE OVERHEATS



If your temperature gauge indicates overheating, you experience a loss of power, or hear loud pinging or knocking, the engine may be overheating. If this happens, you should:

1. Pull off the road and stop as soon as it is safe to do so.
2. Place the shift lever in P (Park, for automatic transaxle/dual clutch transmission vehicle) or neutral (for manual transaxle/dual clutch transmission vehicle) and set the parking brake. If the air conditioning is ON, turn it OFF.

3. If engine coolant is running out under the vehicle or steam is coming out from the hood, stop the engine. Do not open the hood until the coolant has stopped running or the steaming has stopped. If there is no visible loss of engine coolant and no steam, leave the engine running and check to be sure the engine cooling fan is operating. If the fan is not running, turn the engine off.

### WARNING

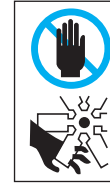

**While the engine is running, keep hands, clothing and tools away from the moving parts such as the cooling fan and drive belt to prevent serious injury.**

4. Check for coolant leaking from the radiator, hoses or under the vehicle. (If the air conditioning had been in use, it is normal for cold water to be draining from it when you stop.)
5. If engine coolant is leaking out, stop the engine immediately and we recommend that you call an authorized HYUNDAI dealer for assistance.



**⚠ WARNING**

**NEVER** remove the radiator cap or the drain plug while the engine and radiator are hot. Hot coolant and steam may blow out under pressure, causing serious injury. Turn the engine off and wait until the engine cools down. Use extreme care when removing the radiator cap. Wrap a thick towel around it, and turn it counterclockwise slowly to the first stop. Step back while the pressure is released from the cooling system. When you are sure all the pressure has been released, press down on the cap, using a thick towel, and continue turning counterclockwise to remove it.

6. If you cannot find the cause of the overheating, wait until the engine temperature has returned to normal. Then, if coolant has been lost, carefully add coolant to the reservoir to bring the fluid level in the reservoir up to the halfway mark.
7. Proceed with caution, keeping alert for further signs of overheating. If overheating happens again, we recommend that you call an authorized HYUNDAI dealer for assistance.

**⚠ CAUTION**

- **Serious loss of coolant indicates a leak in the cooling system and we recommend the system be checked by an authorized HYUNDAI dealer.**
- **When the engine overheats from low engine coolant, suddenly adding engine coolant may cause cracks in the engine. To prevent damage, add engine coolant slowly in small quantities.**

## TIRE PRESSURE MONITORING SYSTEM (TPMS) (IF EQUIPPED)

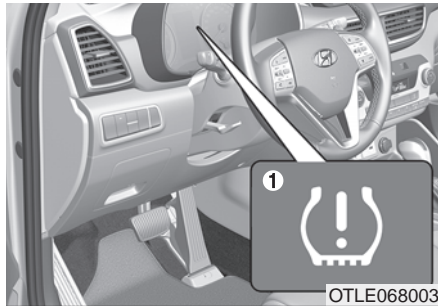

- (1) Low Tire Pressure Telltale/  
TPMS Malfunction Indicator
- (2) Low tire pressure position telltale  
and tire pressure telltale  
(Shown on the LCD display)

### Check tire pressure



- You can check the tire pressure in the Assist mode on the cluster.  
**Refer to the "LCD Display Modes" in chapter 3.**
- Tire pressure is displayed few minutes later after driving.
- If tire pressure is not displayed when the vehicle is stopped, "Drive to display" message will appear. After driving, check the tire pressure.

- You can change the tire pressure unit in the User Settings mode on the instrument cluster.
  - **psi, kpa, bar (Refer to "User Settings mode" in chapter 3).**

## Tire pressure monitoring system

### WARNING

**Over-inflation or under-inflation can reduce tire life, adversely affect vehicle handling, and lead to sudden tire failure that may cause loss of vehicle control resulting in an accident.**

Each tire, including the spare (if provided), should be checked monthly when cold and inflated to the inflation pressure recommended by the vehicle manufacturer on the vehicle placard or tire inflation pressure label. (If your vehicle has tires of a different size than the size indicated on the vehicle placard or tire inflation pressure label, you should determine the proper tire inflation pressure for those tires.)

As an added safety feature, your vehicle has been equipped with a tire pressure monitoring system (TPMS) that illuminates a low tire pressure telltale when one or more of your tires is significantly under-inflated. Accordingly, when the low tire pressure telltale illuminates, you should stop and check your tires as soon as possible, and inflate them to the proper pressure. Driving on a significantly under-inflated tire causes the tire to overheat and can lead to tire failure. Under-inflation also reduces fuel efficiency and tire tread life, and may affect the vehicle's handling and stopping ability.

Please note that the TPMS is not a substitute for proper tire maintenance, and it is the driver's responsibility to maintain correct tire pressure, even if under-inflation has not reached the level to trigger illumination of the TPMS low tire pressure telltale.

Your vehicle has also been equipped with a TPMS malfunction indicator to indicate when the system is not operating properly. The TPMS malfunction indicator is combined with the low tire pressure telltale. When the system detects a malfunction, the telltale will flash for approximately one minute and then remain continuously illuminated. This sequence will continue upon subsequent vehicle start-ups as long as the malfunction exists. When the malfunction indicator is illuminated, the system may not be able to detect or signal low tire pressure as intended.

TPMS malfunctions may occur for a variety of reasons, including the installation of replacement or alternate tires or wheels on the vehicle that prevent the TPMS from functioning properly. Always check the TPMS malfunction telltale after replacing one or more tires or wheels on your vehicle to ensure that the replacement or alternate tires and wheels allow the TPMS to continue to function properly.

### NOTICE

If any of the below happens, we recommend that the system be checked by an authorized HYUNDAI dealer.

1. The low tire pressure telltale/TPMS malfunction indicator does not illuminate for 3 seconds when Engine Start/Stop button is turned to the ON or engine is running.
2. The TPMS malfunction indicator remains illuminated after blinking for approximately 1 minute.
3. The Low tire pressure position telltale remains illuminated.



Low tire pressure telltale

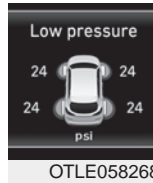

Low tire pressure position telltale and tire pressure telltale

When the tire pressure monitoring system warning indicators are illuminated and warning message displayed on the cluster LCD display, one or more of your tires is significantly under-inflated. The low tire pressure position telltale light will indicate which tire is significantly under-inflated by illuminating the corresponding position light.

If either telltale illuminates, immediately reduce your speed, avoid hard cornering and anticipate increased stopping distances.

You should stop and check your tires as soon as possible. Inflate the tires to the proper pressure as indicated on the vehicle's placard or tire inflation pressure label located on the driver's side center pillar outer panel. If you cannot reach a service station or if the tire cannot hold the newly added air, replace the low pressure tire with a spare tire.

If you drive the vehicle for about 10 minutes at speeds above 25 km/h after replacing the low pressure tire with the spare tire, the below will happen:

- The TPMS malfunction indicator may blink for approximately 1 minute and then remain continuously illuminated because the TPMS sensor is not mounted on the spare wheel.

### NOTICE

**The spare tire is not equipped with a tire pressure sensor.**

 **CAUTION**

In winter or cold weather, the low tire pressure telltale may illuminate if the tire pressure was adjusted to the recommended tire inflation pressure in warm weather. It does not mean your TPMS is malfunctioning because the decreased temperature leads to a lowering of tire pressure.

When you drive your vehicle from a warm area to a cold area or from a cold area to a warm area, or the outside temperature is higher or lower, you should check the tire inflation pressure and adjust the tires to the recommended tire inflation pressure.

 **WARNING**

**Low pressure damage**

**Significantly low tire pressure makes the vehicle unstable and can contribute to loss of vehicle control and increased braking distances.**

**Continued driving on low pressure tires can cause the tires to overheat and fail.**



**TPMS (Tire Pressure Monitoring System) malfunction indicator**

The TPMS malfunction indicator will illuminate after it blinks for approximately one minute when there is a problem with the Tire Pressure Monitoring System.

We recommend that the system be checked by an authorized HYUNDAI dealer.

**NOTICE**

If there is a malfunction with the TPMS, the low tire pressure position telltale will not be displayed even though the vehicle has an under-inflated tire.

 **CAUTION**

- **The TPMS malfunction indicator may blink for approximately 1 minute and then remain continuously illuminated if the vehicle is moving around electric power supply cables or radios transmitter such as at police stations, government and public offices, broadcasting stations, military installations, airports, or transmitting towers, etc. This can interfere with normal operation of the Tire Pressure Monitoring System (TPMS).**
- **The TPMS malfunction indicator may blink for approximately 1 minute and then remain continuously illuminated if snow chains are used or some separate electronic devices such as notebook computer, mobile charger, remote starter or navigation etc., are used in the vehicle.**

**This can interfere with normal operation of the Tire Pressure Monitoring System (TPMS).**

### Changing a tire with TPMS

If you have a flat tire, the low Tire Pressure and Position telltales will come on. We recommend that the system be checked by an authorized HYUNDAI dealer.

 **CAUTION**

**It is recommended that you do not use a puncture-repairing agent not approved by HYUNDAI dealer to repair and/or inflate a low pressure tire. Tire sealant not approved by HYUNDAI dealer may damage the tire pressure sensor.**

Each wheel is equipped with a tire pressure sensor mounted inside the tire behind the valve stem. You must use TPMS specific wheels. It is recommended that you have your tires serviced by an authorized HYUNDAI dealer.

If you drive the vehicle for about 10 minutes at speeds above 25 km/h after replacing the low pressure tire with the spare tire, the below will happen:

- The TPMS malfunction indicator may blink for approximately 1 minute and then remain continuously illuminated because the TPMS sensor is not mounted on the spare wheel.

You may not be able identify a low tire by simply looking at it. Always use a good quality tire pressure gauge to measure the tire's inflation pressure. Please note that a tire that is hot (from being driven) will have a higher pressure measurement than a tire that is cold (from sitting stationary for at least 3 hour and driven less than 1.6 km (1 mile) during that 3 hour period).

Allow the tire to cool before measuring the inflation pressure. Always be sure the tire is cold before inflating to the recommended pressure.

A cold tire means the vehicle has been sitting for 3 hours and driven for less than 1.6 km (1 mile) in that 3 hour period.

### WARNING

- **The TPMS cannot alert you to severe and sudden tire damage caused by external factors such as nails or road debris.**
- **If you feel any vehicle instability, immediately take your foot off the accelerator, apply the brakes gradually and with light force, and slowly move to a safe position off the road.**

### WARNING

**Tampering with, modifying, or disabling the Tire Pressure Monitoring System (TPMS) components may interfere with the system's ability to warn the driver of low tire pressure conditions and/or TPMS malfunctions. Tampering with, modifying, or disabling the Tire Pressure Monitoring System (TPMS) components may void the warranty for that portion of the vehicle.**

**⚠ WARNING**

**For EUROPE**

- Do not modify the vehicle; it may interfere with the TPMS function.
- The wheels on the market do not have a TPMS sensor.

For your safety, we recommend that you use parts for replacement from an authorized HYUNDAI dealer.

- If you use the wheels on the market, use a TPMS sensor approved by a HYUNDAI dealer. If your vehicle is not equipped with a TPMS sensor or TPMS does not work properly, you may fail the periodic vehicle inspection conducted in your country.

(Continued)

(Continued)

\*All vehicles sold in the EUROPE market during below period must be equipped with TPMS.

- New model vehicle :  
Nov. 1, 2012 ~

- Current model vehicle :  
Nov. 1, 2014~ (Based on  
vehicle registrations)



## IF YOU HAVE A FLAT TIRE (WITH SPARE TIRE, IF EQUIPPED)

### WARNING

Changing a tire can be dangerous. Follow the instructions in this section when changing a tire to reduce the risk of serious injury or death.

### CAUTION

Be careful as you use the jack handle to stay clear of the flat end. The flat end has sharp edges that could cause cuts.

### Jack and tools



- (1) Jack handle
- (2) Jack
- (3) Wheel nut wrench

The jack, jack handle, and wheel nut wrench are stored in the luggage compartment under the luggage box cover.

The jack is provided for emergency tire changing only.



Turn the winged hold down bolt counterclockwise to remove the spare tire.

Store the spare tire in the same compartment by turning the winged hold down bolt clockwise.

To prevent the spare tire and tools from "rattling", store them in their proper location.



If it is hard to loosen the tire hold-down wing bolt by hand, you can loosen it easily using the jack handle.

1. Put the jack handle (1) inside of the tire hold-down wing bolt.
2. Turn the tire hold-down wing bolt counterclockwise with the jack handle.

## Changing tires

### **WARNING**

A vehicle can slip or roll off of a jack causing serious injury or death to you or those nearby. Take the following safety precautions:

- Do not get under a vehicle that is supported by a jack.
- **NEVER** attempt to change a tire in the lane of traffic. **ALWAYS** move the vehicle completely off the road on level, firm ground away from traffic before trying to change a tire. If you cannot find a level, firm place off the road, call a towing service for assistance.
- Be sure to use the jack provided with the vehicle.

(Continued)

(Continued)

- **ALWAYS** place the jack on the designated jacking positions on the vehicle and **NEVER** on the bumpers or any other part of the vehicle for jacking support.
- Do not start or run the engine while the vehicle is on the jack.
- Do not allow anyone to remain in the vehicle while it is on the jack.
- Keep children away from the road and the vehicle.

Follow these steps to change your vehicle's tire:

1. Park on a level, firm surface.
2. Move the shift lever into P (Park, for automatic transaxle/dual clutch transmission vehicle) or neutral (for manual transaxle vehicle), apply the parking brake, and place the ignition switch in the LOCK/OFF position.
3. Press the hazard warning flasher button.
4. Remove the wheel lug nut wrench, jack, jack handle, and spare tire from the vehicle.



5. Block both the front and rear of the tire diagonally opposite of the tire you are changing.



6. Loosen the wheel lug nuts counterclockwise one turn each in the order shown above, but do not remove any lug nuts until the tire has been raised off of the ground.

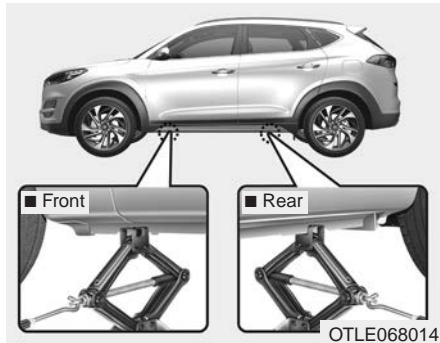

7. Place the jack at the designated jacking position under the frame closest to the tire you are changing. The jacking positions are plates welded to the frame with two notches and two dimples. Never jack any other position or part of the vehicle. It may damage to the side seal molding.



8. Insert the jack handle into the jack and turn it clockwise, raising the vehicle until the tire clears the ground. Make sure the vehicle is stable on the jack.

9. Loosen the lug nuts with the wheel lug nut wrench and remove them with your fingers. Remove the wheel from the studs and lay it flat on the ground out of the way. Remove any dirt or debris from the studs, mounting surfaces, and wheel.

10. Install the spare tire onto the studs of the hub.

11. Tighten the lug nuts with your fingers onto the studs with the smaller end of the lug nuts closest to the wheel.

12. Lower the vehicle to the ground by turning the jack handle counterclockwise.

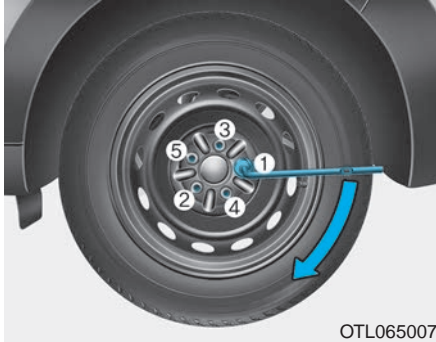

13. Use the wheel lug nut wrench to tighten the lug nuts in the order shown. Double-check each lug nut until they are tight. After changing tires, we recommend that an authorized HYUNDAI dealer tighten the lug nuts to their proper torque as soon as possible. **The wheel lug nut should be tightened to 11~13 kgf-m (79~94 lbf-ft).**

If you have a tire gauge, check the tire pressure (see “Tires and Wheels” in chapter 8 for tire pressure instructions.). If the pressure is lower or higher than recommended, drive slowly to the nearest service station and adjust it to the recommended pressure. Always reinstall the valve cap after checking or adjusting tire pressure. If the cap is not replaced, air may leak from the tire. If you lose a valve cap, buy another and install it as soon as possible. After changing tires, secure the flat tire and return the jack and tools to their proper storage locations.

#### NOTICE

- **Check the tire pressure as soon as possible after installing a spare tire. Adjust it to the recommended pressure.**
- **Check and tighten the wheel lug nuts after driving over 50 km if tires are replaced. Re-check the tire wheel lug nuts after driving over 1,000 km.**

#### CAUTION

**Your vehicle has metric threads on the studs and lug nuts. Make certain during tire changing that the same nuts that were removed are reinstalled. If you have to replace your lug nuts make sure they have metric threads to avoid damaging the studs and ensure the wheel is properly secured to the hub. We recommend that you consult an authorized HYUNDAI dealer for assistance.**

### ***Use of compact spare tires (if equipped)***

Compact spare tires are designed for emergency use only. Drive carefully on the compact spare tire and always follow the safety precautions.

#### **⚠ WARNING**

**To prevent compact spare tire failure and loss of control possibly resulting in an accident:**

- **Use the compact spare tire only in an emergency.**
- **NEVER operate your vehicle over 80 km/h (50 mph).**
- **Do not exceed the vehicle's maximum load rating or the load carrying capacity shown on the sidewall of the compact spare tire.**
- **Do not use the compact spare tire continuously. Repair or replace the original tire as soon as possible to avoid failure of the compact spare tire.**

When driving with the compact spare tire mounted to your vehicle:

- Check the tire pressure after installing the compact spare tire. The compact spare tire should be inflated to 420 kPa (60 psi).
- Do not take this vehicle through an automatic car wash while the compact spare tire is installed.
- Do not use the compact spare tire on any other vehicle because this tire has been designed especially for your vehicle.
- The compact spare tire's tread life is shorter than a regular tire. Inspect your compact spare tire regularly and replace worn compact spare tires with the same size and design, mounted on the same wheel.
- Do not use more than one compact spare tire at a time.
- Do not tow a trailer while the compact spare tire is installed.

#### **NOTICE**

**When the original tire and wheel are repaired and reinstalled on the vehicle, the lug nut torque must be set correctly. The correct lug nut tightening torque is 11-13 kgf-m (79-94 lbf-ft).**

## ⚠ CAUTION

To prevent damaging the compact spare tire and your vehicle:

- Drive slowly enough for the road conditions to avoid all hazards, such as a potholes or debris.
- Avoid driving over obstacles. The compact spare tire diameter is smaller than the diameter of a conventional tire and reduces the ground clearance approximately 25 mm (1 inch).
- Do not use tire chains on the compact spare tire. Because of the smaller size, a tire chain will not fit properly.
- Do not use the compact spare tire on any other wheels, nor should standard tires, snow tires, wheel covers or trim rings be used with the compact spare wheel.

## Jack label

### ■ Example

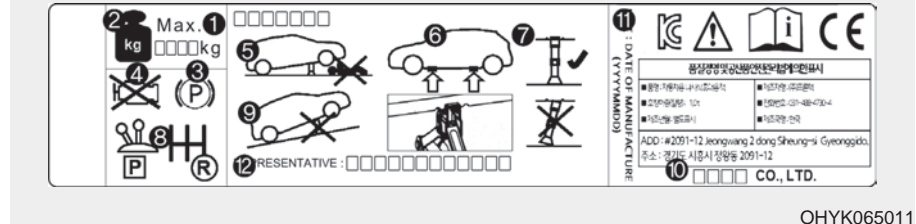



OHYK065011

The actual Jack label in the vehicle may differ from the illustration.  
For more detailed specifications, refer to the label attached to the jack.

1. Model Name
2. Maximum allowable load
3. When using the jack, set your parking brake.
4. When using the jack, stop the engine.
5. Do not get under a vehicle that is supported by a jack.
6. The designated locations under the frame
7. When supporting the vehicle, the base plate of jack must be vertical under the lifting point.
8. Shift into Reverse gear on vehicles with manual transaxle or move the shift lever to the P position on vehicles with automatic transaxle/dual clutch transmission.
9. The jack should be used on firm level ground.
10. Jack manufacture
11. Production date
12. Representative company and address

## EC Declaration of conformity for Jack

	
<b>EC Declaration of Conformity</b> according to EC Machinery Directive 2006/42/EC	
We, <b>FRONTEC CO., LTD.</b> 2091-12 Jeongwang 2(i)-dong Siheung-si Gyeonggi-d ,Korea declare under our sole responsibility that the product	
<b>Product</b>	: JACK-ASSY
<b>Type Designation(s)</b>	: 1200KG, 1000KG, 800KG, 700KG, 500KG
<b>Serial No.</b>	: N/A (prototype)
<b>Year of Manufacture</b>	: 2013
to which this declaration relates is in conformity with the following standard(s) or other normative document(s):	
EN ISO12100 (2010)	Safety of machinery - General principles for design – Risk assessment and risk reduction
EN 1494/A1 (2008)	Mobile or movable jacks and associated lifting equipment
following the provisions of Directive(s):	
2006/42/EC	Directive on the approximation of the laws of Member States relating to machinery (OJ L157 Jun, 9, 2006)
 <u>Siheung-si Gyeonggi-d ,Korea / 15.07.2013</u> <u>SOO HONG, MIN</u> <u>President</u> 	
(Place and date of issue)(Name and signature or equivalent making of authorized person)	
* T.C.F Compiling Location: - Address: PRIBORSKA 280, 739 42 FRYDEK MISTEK, CHLEBOVICE, CZECH REPUBLIC - Team: Purchase team - Company name: HANWHIA L&C CZECH s.r.o	

JACKDOC14F



## IF YOU HAVE A FLAT TIRE (WITH TIRE MOBILITY KIT, IF EQUIPPED) – TYPE A



For safe operation, carefully read and follow the instructions in this manual before use.

- (1) Compressor
- (2) Sealant bottle

The Tire Mobility Kit is a temporary fix to the tire and we recommend that the system be inspected by an authorized HYUNDAI dealer.

### ⚠ CAUTION

When two or more tires are flat, do not use the tire mobility kit because the supported one sealant of Tire Mobility Kit is only used for one flat tire.

### ⚠ WARNING

Do not use the Tire Mobility Kit to repair punctures in the tire walls. This can result in an accident due to tire failure.

### ⚠ WARNING

Have your tire repaired as soon as possible. The tire may lose air pressure at any time after inflating with the Tire Mobility Kit.

### Introduction



With the Tire Mobility Kit you stay mobile even after experiencing a tire puncture.

The system of compressor and sealing compound effectively and comfortably seals most punctures in a passenger car tire caused by nails or similar objects and reinflates the tire.

After you ensured that the tire is properly sealed you can drive cautiously on the tire (distance up to 200 km (120 miles)) at a max. speed of 80 km/h (50 mph) in order to reach a service station or tire dealer to have the tire replaced.

It is possible that some tires, especially with larger punctures or damage to the sidewall, cannot be sealed completely.

Air pressure loss in the tire may adversely affect tire performance.

For this reason, you should avoid abrupt steering or other driving maneuvers, especially if the vehicle is heavily loaded or if a trailer is in use.

The Tire Mobility Kit is not designed or intended as a permanent tire repair method and is to be used for one tire only. This instruction shows you step by step how to temporarily seal the puncture simply and reliably. Read the section "Notes on the safe use of the Tire Mobility Kit".

### WARNING

**Do not use the TMK if a tire is severely damaged by driving run flat or with insufficient air pressure.**

**Only punctured areas located within the tread region of the tire can be sealed using the TMK.**

### Notes on the safe use of the Tire Mobility Kit

- Park your car at the side of the road so that you can work with the Tire Mobility Kit away from moving traffic.
- To be sure your vehicle will not move, even when you're on fairly level ground, always set your parking brake.
- Only use the Tire Mobility Kit for sealing/inflation passenger car tires. Only punctured areas located within the tread region of the tire can be sealed using the tire mobility kit.
- Do not use on motorcycles, bicycles or any other type of tires.
- When the tire and wheel are damaged, do not use Tire Mobility Kit for your safety.
- Use of the Tire Mobility Kit may not be effective for tire damage larger than approximately 6 mm (0.24 in).  
If the tire cannot be made roadworthy with the Tire Mobility Kit, we recommend that you contact an authorized HYUNDAI dealer.
- Do not use the Tire Mobility Kit if a tire is severely damaged by driving run flat or with insufficient air pressure.

- Do not remove any foreign objects such as nails or screws that have penetrated the tire.
- Provided the car is outdoors, leave the engine running. Otherwise operating the compressor may eventually drain the car battery.
- Never leave the Tire Mobility Kit unattended while it is being used.
- Do not leave the compressor running for more than 10 min. at a time or it may overheat.
- Do not use the Tire Mobility Kit if the ambient temperature is below -30°C (-22°F).
- In case of skin contact with the sealant, wash the area thoroughly with plenty of water. If the irritation persists, seek medical attention.
- In case of eye contact with the sealant, flush your eyes for at least 15 minutes. If the irritation persists, seek medical attention.
- In case of swallowing the sealant, rinse the mouth and drink plenty of water. However, never give anything to an unconscious person and seek medical attention immediately.
- Long time exposure to the sealant may cause damage to bodily tissue such as kidney, etc

## Components of the Tire Mobility Kit

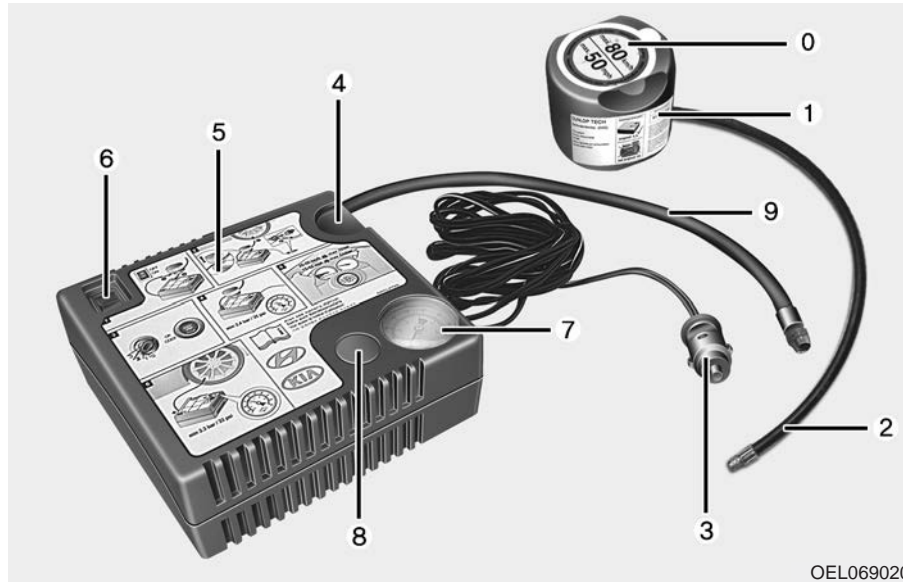

0. Speed- restriction label
1. Sealant bottle and label with speed restriction
2. Filling hose from sealant bottle to wheel
3. Connectors and cable for the power outlet direct connection
4. Holder for the sealant bottle
5. Compressor
6. On/off switch
7. Pressure gauge for displaying the tire inflation pressure
8. Button for reducing tire inflation pressure
9. Hose to connect compressor and sealant bottle or compressor and wheel

9. Hose to connect compressor and sealant bottle or compressor and wheel

Connectors, cable and connection hose are stored in the compressor housing.

### WARNING

#### Expired sealant

Do not use the Tire sealant after the sealant has expired (i.e. pasted the expiration date on the sealant container). This can increase the risk of tire failure.

### WARNING

#### Sealant

- Keep out of reach of children.
- Avoid contact with eyes.
- Do not swallow.

Strictly follow the specified sequence, otherwise the sealant may escape under high pressure.

### Using the Tire Mobility Kit

1. Detach the speed restriction label (0) from the sealant bottle (1), and place it in a highly visible place inside the vehicle such as on the steering wheel to remind the driver not to drive too fast.
2. Screw connection hose (9) onto the connector of the sealant bottle.
3. Ensure that button (8) on the compressor is not pressed.
4. Unscrew the valve cap from the valve of the defective wheel and screw filling hose (2) of the sealant bottle onto the valve.
5. Insert the sealant bottle into the housing of the compressor (4) so that the bottle is upright.



6. Ensure that the compressor is switched off, position 0.



#### CAUTION

**Securely install the sealant filling hose to the valve. If not, sealant may flow backward, possibly clogging the filling hose.**

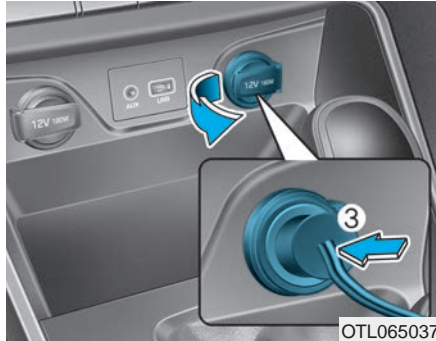

7. Connect between compressor and the vehicle power outlet using the cable and connectors.

**⚠ WARNING**

Only use the front passenger side power outlet when connecting the power cord.

8. With the engine start/stop button position on or ignition switch position on, switch on the compressor and let it run for approximately 5~7 minutes to fill the sealant up to proper pressure. (refer to the Tire and Wheels, chapter 8). The inflation pressure of the tire after filling is unimportant and will be checked/corrected later.

Be careful not to overinflate the tire and stay away from the tire when filling it.

**⚠ CAUTION**

**Tire pressure**

Do not attempt to drive your vehicle if the tire pressure is below 29 PSI (200kpa). This could result in an accident due to sudden tire failure.

9. Switch off the compressor.  
10. Detach the hoses from the sealant bottle connector and from the tire valve.

Return the Tire Mobility Kit to its storage location in the vehicle.

**⚠ WARNING**

**Carbon monoxide**

Do not leave your vehicle running in a poorly ventilated area for extended periods of time. Carbon monoxide poisoning and suffocation can occur.

### Distributing the sealant

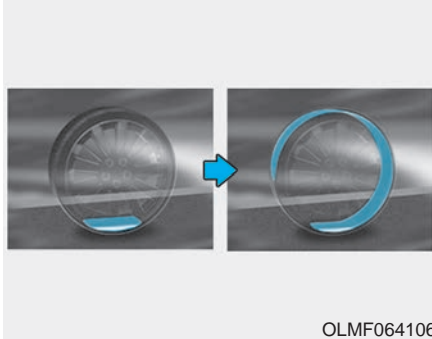

OLMF064106

11. Immediately drive approximately 7~10 km (4~6 miles or, about 10min) to evenly distribute the sealant in the tire.

### CAUTION

Do not exceed a speed of 80 km/h (50 mph). If possible, do not fall below a speed of 20 km/h (12 mph).

While driving, if you experience any unusual vibration, ride disturbance or noise, reduce your speed and drive with caution until you can safely pull off of the side of the road.

**Call for road side service or towing. When you use the Tire Mobility Kit, the tire pressure sensors and wheel may be damaged by sealant, remove the sealant stained with tire pressure sensors and wheel and inspect in authorized dealer.**

### Checking the tire inflation pressure



OTLE068038

1. After driving approximately 7~10 km (4~6 miles or about 10 min), stop at a safety location.
2. Connect connection hose (9) of the compressor directly to the tire valve.
3. Plug the compressor power cord into the vehicle power outlet.
4. Adjust the tire inflation pressure to the recommended tire inflation.  
With the ignition switched on, proceed as follows.

- **To increase the inflation pressure** : Switch on the compressor, position I. To check the current inflation pressure setting, briefly switch off the compressor.

### WARNING

Do not let the compressor run for more than 10 minutes, otherwise the device will overheat and may be damaged.

### NOTICE

The pressure gauge may show higher than actual reading when the compressor is running. To get an accurate tire reading, the compressor needs to be turned off.

- **To reduce the inflation pressure**: Press the button 8 on the compressor.

### CAUTION

If the inflation pressure is not maintained, drive the vehicle a second time, refer to Distributing the sealant. Then repeat steps 1 to 4.

Use of the TMK may be ineffectual for tire damage larger than approximately 4 mm (0.16 in).

We recommend that you contact an authorized HYUNDAI dealer if the tire cannot be made road-worthy with the Tire Mobility Kit.

### WARNING

The tire inflation pressure must be at least 220 kPa (32 psi). If it is not, do not continue driving. Call for road side service or towing.

### CAUTION

#### Tire pressure sensor

The sealant on the tire pressure sensor and wheel should be removed when you replace the tire with a new one and inspect the tire pressure sensors in authorized dealer.

When reinstalling the repaired or replaced tire and wheel on the vehicle, tighten the wheel lug nut to 11~13 kgf·m (79~94 lbf·ft).

- \* Sealant and spare parts can be obtained and replaced at an authorized vehicle or tire dealer. Empty sealant bottles may be disposed of at home. Liquid residue from the sealant should be disposed of by your vehicle or tire dealer or in accordance with local waste disposal regulations.



## IF YOU HAVE A FLAT TIRE (WITH TIRE MOBILITY KIT, IF EQUIPPED) – TYPE B



For safe operation, carefully read and follow the instructions in this manual before use.

- (1) Compressor
- (2) Sealant bottle

The Tire Mobility Kit is a temporary fix to the tire and we recommend that the system be inspected by an authorized HYUNDAI dealer.

### CAUTION

**When two or more tires are flat, do not use the tire mobility kit because the supported one sealant of Tire Mobility Kit is only used for one flat tire.**

### WARNING

**Do not use the Tire Mobility Kit to repair punctures in the tire walls. This can result in an accident due to tire failure.**

### WARNING

**Have your tire repaired as soon as possible. The tire may lose air pressure at any time after inflating with the Tire Mobility Kit.**

### Introduction

With the Tire Mobility Kit you stay mobile even after experiencing a tire puncture.

The system of compressor and sealing compound effectively and comfortably seals most punctures in a passenger car tire caused by nails or similar objects and reinflates the tire.

After you ensured that the tire is properly sealed you can drive cautiously on the tire (distance up to 200 km (120 miles)) at a max. speed of 80 km/h (50 mph) in order to reach a service station or tire dealer to have the tire replaced.

It is possible that some tires, especially with larger punctures or damage to the sidewall, cannot be sealed completely.

Air pressure loss in the tire may adversely affect tire performance.

For this reason, you should avoid abrupt steering or other driving maneuvers, especially if the vehicle is heavily loaded or if a trailer is in use.



The Tire Mobility Kit is not designed or intended as a permanent tire repair method and is to be used for one tire only. This instruction shows you step by step how to temporarily seal the puncture simply and reliably. Read the section "Notes on the safe use of the Tire Mobility Kit".

### WARNING

**Do not use the TMK if a tire is severely damaged by driving run flat or with insufficient air pressure.**

**Only punctured areas located within the tread region of the tire can be sealed using the TMK.**

### Notes on the safe use of the Tire Mobility Kit

- Park your car at the side of the road so that you can work with the Tire Mobility Kit away from moving traffic.
- To be sure your vehicle will not move, even when you're on fairly level ground, always set your parking brake.
- Only use the Tire Mobility Kit for sealing/inflation passenger car tires. Only punctured areas located within the tread region of the tire can be sealed using the tire mobility kit.
- Do not use on motorcycles, bicycles or any other type of tires.
- When the tire and wheel are damaged, do not use Tire Mobility Kit for your safety.
- Use of the Tire Mobility Kit may not be effective for tire damage larger than approximately 6 mm (0.24 in).  
If the tire cannot be made roadworthy with the Tire Mobility Kit, we recommend that you contact an authorized HYUNDAI dealer.
- Do not use the Tire Mobility Kit if a tire is severely damaged by driving run flat or with insufficient air pressure.
- Do not remove any foreign objects such as nails or screws that have penetrated the tire.
- Provided the car is outdoors, leave the engine running. Otherwise operating the compressor may eventually drain the car battery.
- Never leave the Tire Mobility Kit unattended while it is being used.
- Do not leave the compressor running for more than 10 min. at a time or it may overheat.
- Do not use the Tire Mobility Kit if the ambient temperature is below -30°C (-22°F).
- In case of skin contact with the sealant, wash the area thoroughly with plenty of water. If the irritation persists, seek medical attention.
- In case of eye contact with the sealant, flush your eyes for at least 15 minutes. If the irritation persists, seek medical attention.
- In case of swallowing the sealant, rinse the mouth and drink plenty of water. However, never give anything to an unconscious person and seek medical attention immediately.
- Long time exposure to the sealant may cause damage to bodily tissue such as kidney, etc.

### Components of the Tire Mobility Kit

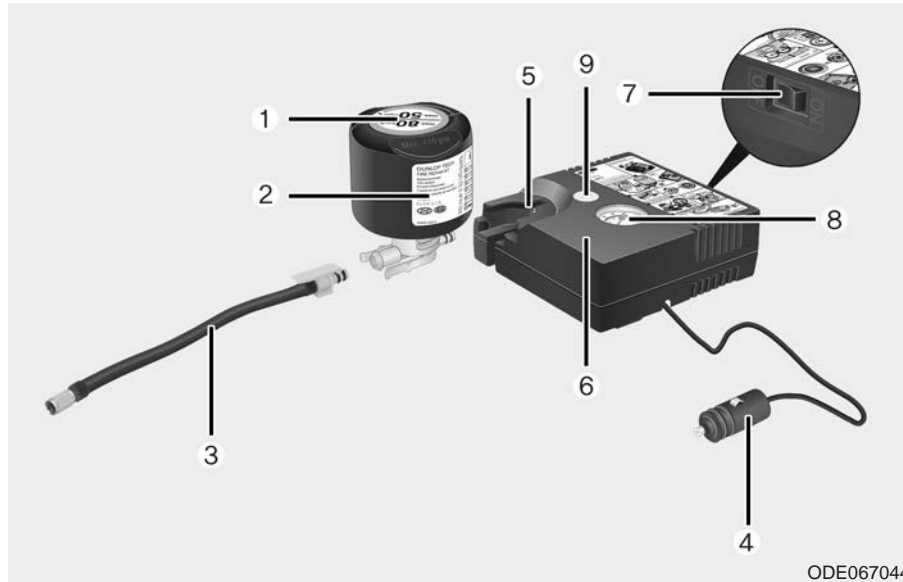

1. Speed-restriction label
2. Sealant bottle and label with speed restriction
3. Filling hose from sealant bottle to wheel
4. Connectors and cable for the power outlet direct connection
5. Holder for the sealant bottle
6. Compressor
7. ON/OFF switch
8. Pressure gauge for displaying the tire inflation pressure
9. Button for reducing the tire inflation pressure

Connectors, cable and connection hose are stored in the compressor housing.

Strictly follow the specified sequence, otherwise the sealant may escape under high pressure.

#### WARNING

##### Expired sealant

**Do not use the Tire sealant after the sealant has expired (i.e. pasted the expiration date on the sealant container). This can increase the risk of tire failure.**

#### WARNING

##### Sealant

- **Keep out of reach of children.**
- **Avoid contact with eyes.**
- **Do not swallow.**

## Using the Tire Mobility Kit

### CAUTION

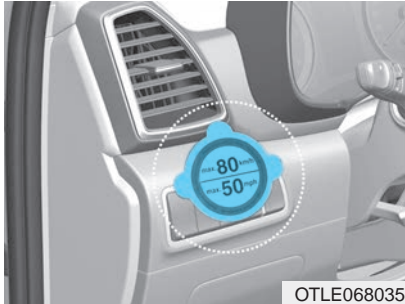

Detach the speed restriction label (1) from the sealant bottle (2), and place it in a highly visible place inside the vehicle such as on the steering wheel to remind the driver not to drive too fast.

1. Shake the sealant bottle (2).
2. Connect the filling hose (3) to the sealant bottle (2) in the direction of (A) and connect the sealant bottle to the compressor (6) in the direction of (B).

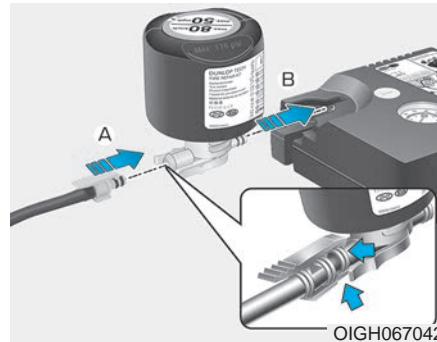

3. Ensure that the compressor is switched OFF.
4. Unscrew the valve cap from the valve of the defective wheel and screw the filling hose (3) of the sealant bottle onto the valve.

### CAUTION

Securely install the sealant filling hose to the valve. If not, sealant may flow backward, possibly clogging the filling hose.



5. Plug the compressor power cord (4) into the vehicle power outlet.

### NOTICE

**Only use the front passenger side power outlet when connecting the power cord.**

6. With the ignition switch in the ON position, switch on the compressor and let it run for approximately 5~7 minutes to fill the sealant up to proper pressure. (refer to the Tire and Wheels, chapter 8). The inflation pressure of the tire after filling is unimportant and will be checked/corrected later.

Be careful not to overinflate the tire and stay away from the tire when filling it.



### CAUTION

#### Tire pressure

**Do not attempt to drive your vehicle if the tire pressure is below 200 kPa (29 psi). This could result in an accident due to sudden tire failure.**

7. Switch off the compressor.
8. Detach the hoses from the sealant bottle connector and from the tire valve.

Return the Tire Mobility Kit to its storage location in the vehicle.



### WARNING

#### Carbon monoxide

**Do not leave your vehicle running in a poorly ventilated area for extended periods of time. Carbon monoxide poisoning and suffocation can occur.**

## Distributing the sealant

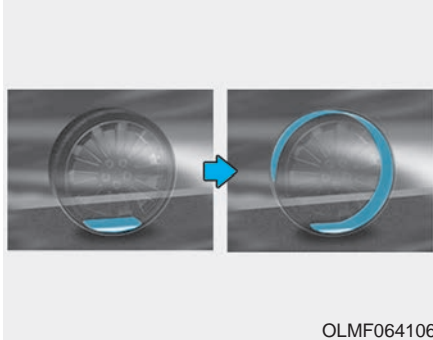

9. Immediately drive approximately 7~10 km (4~6 miles or, about 10min) to evenly distribute the sealant in the tire.

Do not exceed a speed of 80 km/h (50 mph). If possible, do not fall below a speed of 20 km/h (12 mph).

While driving, if you experience any unusual vibration, ride disturbance or noise, reduce your speed and drive with caution until you can safely pull off of the side of the road.

Call for road side service or towing. When you use the Tire Mobility Kit, the tire pressure sensors and wheel may be damaged by sealant, remove the sealant stained with tire pressure sensors and wheel and inspect in authorized dealer.

## Checking the tire inflation pressure

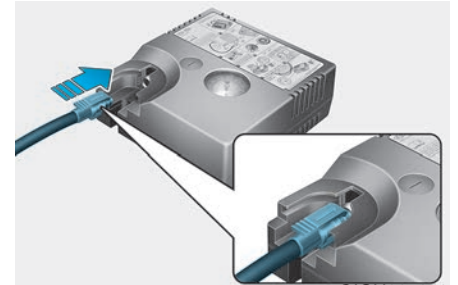

1. After driving approximately 7~10 km (4~6 miles or about 10 min), stop at a safety location.
2. Connect the filling hose (3) of the compressor directly to the tire valve.

3. Plug the compressor power cord into the vehicle power outlet.
4. Adjust the tire inflation pressure to the recommended tire inflation.  
With the ignition switched on, proceed as follows.
  - **To increase the inflation pressure** : Switch on the compressor. To check the current inflation pressure setting, briefly switch off the compressor.
  - **To reduce the inflation pressure**: Press the button (9) on the compressor.

### NOTICE

Do not let the compressor run for more than 10 minutes, otherwise the device will overheat and may be damaged.

### **i** Information

The pressure gauge may show higher than actual reading when the compressor is running. To get an accurate tire reading, the compressor needs to be turned off.

### CAUTION

If the inflation pressure is not maintained, drive the vehicle a second time, refer to Distributing the sealant. Then repeat steps 1 to 4.

Use of the TMK may be ineffective for tire damage larger than approximately 4 mm (0.16 in).

We recommend that you contact an authorized HYUNDAI dealer if the tire cannot be made road-worthy with the Tire Mobility Kit.

### WARNING

The tire inflation pressure must be at least 220 kPa (32 psi). If it is not, do not continue driving.

Call for road side service or towing.

### CAUTION

#### Tire pressure sensor

The sealant on the tire pressure sensor and wheel should be removed when you replace the tire with a new one and inspect the tire pressure sensors at an authorized dealer.

When reinstalling the repaired or replaced tire and wheel on the vehicle, tighten the wheel lug nut to 11~13 kgf·m (79~94 lbf·ft).

## TOWING

### Towing service

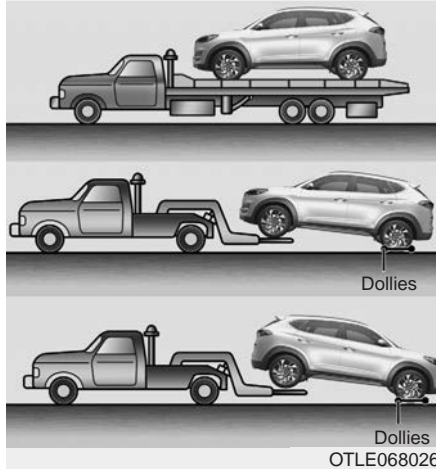

If emergency towing is necessary, we recommend having it done by an authorized HYUNDAI dealer or a commercial tow-truck service.

Proper lifting and towing procedures are necessary to prevent damage to the vehicle. The use of wheel dollies or flatbed is recommended.

On 4WD vehicles, your vehicle must be towed with a wheel lift and dollies or flatbed equipment with all the wheels off the ground.

#### CAUTION

**The 4WD vehicle should never be towed with the wheels on the ground. This can cause serious damage to the transaxle or the 4WD system.**

On 2WD vehicles, it is acceptable to tow the vehicle with the rear wheels on the ground (without dollies) and the front wheels off the ground.

If any of the loaded wheels or suspension components are damaged or the vehicle is being towed with the front wheels on the ground, use a towing dolly under the front wheels.

When being towed by a commercial tow truck and wheel dollies are not used, the front of the vehicle should always be lifted, not the rear.

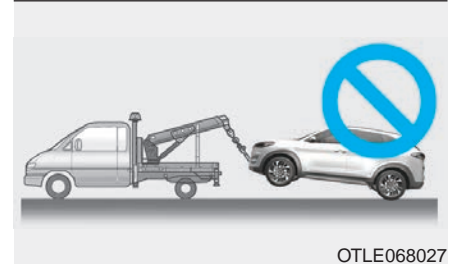

#### CAUTION

- Do not tow the vehicle with the front wheels on the ground as this may cause damage to the vehicle.
- Do not tow with sling-type equipment. Use wheel lift or flatbed equipment.

### **⚠ WARNING**

If your vehicle is equipped with a rollover sensor, place the ignition switch in the **LOCK/OFF** or **ACC** position when the vehicle is being towed. The side impact and curtain air bag may deploy if the sensor detects the situation as a rollover.

When towing your vehicle in an emergency without wheel dollies:

1. Place the ignition switch in the ACC position.
2. Place the shift lever in N (Neutral).
3. Release the parking brake.

### **⚠ CAUTION**

**Failure to place the shift lever in N (Neutral) may cause internal damage to the transaxle.**

## Removable towing hook



1. Open the tailgate, and remove the towing hook from the tool case.

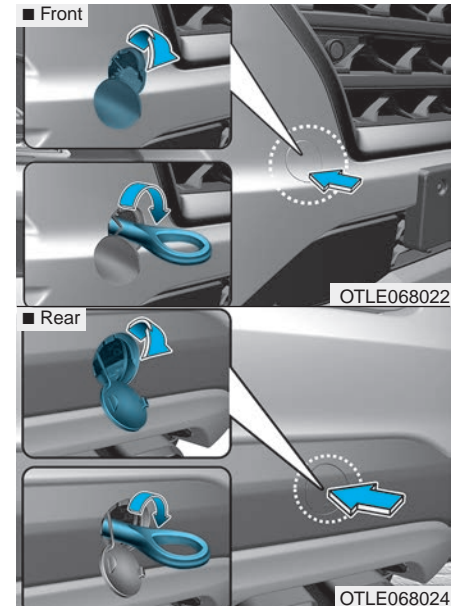

2. Remove the hole cover pressing the lower part of the cover on the front bumper.
3. Install the towing hook by turning it clockwise into the hole until it is fully secured.
4. Remove the towing hook and install the cover after use.



## Emergency towing

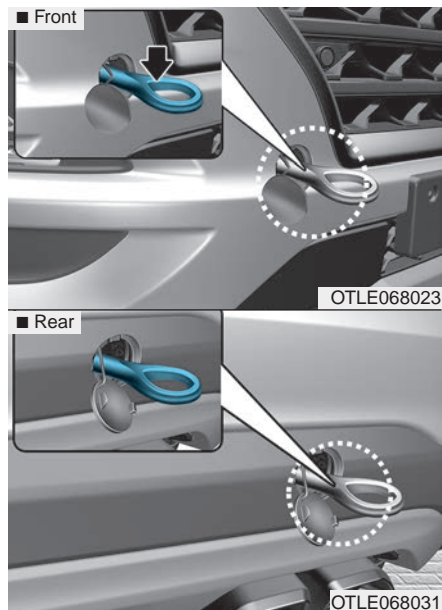

If towing is necessary, we recommend you have it done by an authorized HYUNDAI dealer or a commercial tow truck service.

If towing service is not available in an emergency, your vehicle may be temporarily towed using a cable or chain secured to the emergency towing hook at the front (or rear) of the vehicle.

Use extreme caution when towing the vehicle with a cable or chain. A driver must be in the vehicle to steer it and operate the brakes.

Towing in this manner may be done only on hard-surfaced roads for a short distance and at low speeds. Also, the wheels, axles, power train, steering and brakes must all be in good condition.

### CAUTION

**The driver must be in the vehicle for steering and braking operations when the vehicle is being towed. Passengers other than the driver must not be in the vehicle.**

Always follow these emergency towing precautions:

- Place the ignition switch in the ACC position so the steering wheel is not locked.
- Place the shift lever in N (Neutral).
- Release the parking brake.
- Depress the brake pedal with more force than normal since you will have reduced braking performance.
- More steering effort will be required because the power steering system will be disabled.
- Use a vehicle heavier than your own to tow your vehicle.
- The drivers of both vehicles should communicate with each other frequently.
- Before emergency towing, check that the hook is not broken or damaged.
- Fasten the towing cable or chain securely to the hook.
- Do not jerk the hook. Apply steady and even force.

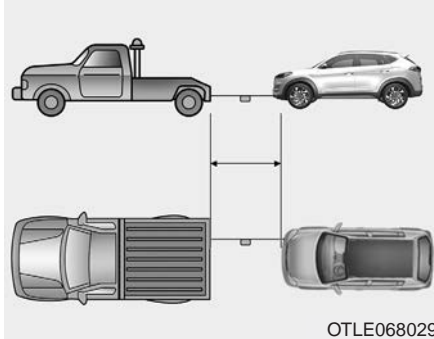

- Use a towing cable or chain less than 5 m (16 feet) long. Attach a white or red cloth (about 30 cm (12 inches) wide) in the middle of the cable or chain for easy visibility.
- Drive carefully so the towing cable or chain remains tight during towing.
- Before towing, check the automatic transaxle/dual clutch transmission for fluid leaks under your vehicle. If the automatic transaxle fluid is leaking, flatbed equipment or a towing dolly must be used.

### NOTICE

Accelerate or decelerate the vehicle in a slow and gradual manner while maintaining tension on the tow rope or chain to start or drive the vehicle, otherwise tow hooks and the vehicle may be damaged.

### NOTICE

To avoid damage to your vehicle and vehicle components when towing:

- Always pull straight ahead when using the towing hooks. Do not pull from the side or at a vertical angle.
- Do not use the towing hooks to pull a vehicle out of mud, sand or other conditions from which the vehicle cannot be driven out under its own power.
- Limit the vehicle speed to 15 km/h (10 mph) and drive less than 1.5 km (1 mile) when towing to avoid serious damage to the automatic transaxle.

## EMERGENCY COMMODITY (IF EQUIPPED)

Your vehicle is equipped with emergency commodities to help you respond to emergency situation.

### Fire extinguisher

If there is small fire and you know how to use the fire extinguisher, follow these steps carefully.

1. Pull out the safety pin at the top of the extinguisher that keeps the handle from being accidentally pressed.
2. Aim the nozzle towards the base of the fire.
3. Stand approximately 2.5 m (8 ft) away from the fire and squeeze the handle to discharge the extinguisher. If you release the handle, the discharge will stop.
4. Sweep the nozzle back and forth at the base of the fire. After the fire appears to be out, watch carefully since it may re-ignite.

### First aid kit

Supplies for use in giving first aid such as scissors, bandage and adhesive tape, etc. are provided.

### Triangle reflector

Place the triangle reflector on the road to warn oncoming vehicles during emergencies, such as when the vehicle is parked by the roadside due to problems.

### Tire pressure gauge (if equipped)

Tires normally lose some air in day-to-day use, and you may have to add a air periodically and usually it is not a sign of a leaking tire, but of normal wear. Always check tire pressure when the tires are cold because tire pressure increases with temperature.

To check the tire pressure, take the following steps:

1. Unscrew the inflation valve cap that is located on the rim of the tire.
2. Press and hold the gauge against the tire valve. Some air will leak as you begin and more will leak if you don't press the gauge in firmly.
3. A firm non-leaking push will activate the gauge.
4. Read the tire pressure on the gauge to see whether the tire pressure is low or high.
5. Adjust the tire pressure to the specified pressure. Refer to "Tires and Wheels" in chapter 8.
6. Reinstall the inflation valve cap.

# Maintenance

<b>Engine compartment</b> .....	7-3
<b>Maintenance services</b> .....	7-6
Owner's responsibility.....	7-6
Owner maintenance precautions .....	7-6
<b>Owner maintenance</b> .....	7-7
Owner maintenance schedule.....	7-8
<b>Scheduled maintenance services</b> .....	7-10
Normal Maintenance Schedule (For Europe, Except Russia) .....	7-11
Maintenance Under Severe Usage and Low Mileage Conditions (For Europe, Except Russia) .....	7-16
Normal Maintenance Schedule (Except Europe, For Russia) .....	7-18
Maintenance Under Severe Usage and Low Mileage Conditions (Except Europe, For Russia) .....	7-23
<b>Explanation of scheduled maintenance items</b> .....	7-26
<b>Engine oil</b> .....	7-29
Checking the engine oil level (Gasoline engine) .....	7-29
Checking the engine oil level (Diesel engine).....	7-30
Checking the engine oil and filter .....	7-32
<b>Engine coolant</b> .....	7-33
Checking the engine coolant level.....	7-33
Changing the engine coolant.....	7-36
<b>Brake/clutch fluid</b> .....	7-37
Checking the brake/clutch fluid level.....	7-37
<b>Washer fluid</b> .....	7-38
Checking the washer fluid level.....	7-38
<b>Parking brake</b> .....	7-38
Checking the parking brake .....	7-38
<b>Fuel Filter (For Diesel)</b> .....	7-39
Draining water from fuel filter.....	7-39
Fuel filter cartridge replacement.....	7-39
<b>Air cleaner</b> .....	7-40
Filter replacement.....	7-40
<b>Climate control air filter</b> .....	7-42
Filter inspection.....	7-42
Filter replacement.....	7-42
<b>Wiper blades</b> .....	7-43
Blade inspection .....	7-43
Blade replacement .....	7-43
<b>Battery</b> .....	7-46
For best battery service.....	7-46
Battery capacity label .....	7-48
Battery recharging .....	7-48
Reset items .....	7-49
<b>Tires and wheels</b> .....	7-50
Tire care .....	7-50
Recommended cold tire inflation pressures.....	7-50
Checking tire inflation pressure.....	7-52
Tire rotation .....	7-53

Wheel alignment and tire balance .....	7-54
Tire replacement .....	7-54
Wheel replacement .....	7-56
Tire traction.....	7-56
Tire maintenance .....	7-56
Tire sidewall labeling.....	7-56
Low aspect ratio tire .....	7-61
<b>Fuses</b> .....	<b>7-62</b>
Fuse/Relay panel description .....	7-67
<b>Light bulbs</b> .....	<b>7-81</b>
Headlamp, Low Beam Assist - Static, Position lamp, Turn signal lamp and Fog lamp light bulb replacement .....	7-82
Side repeater lamp replacement .....	7-87
Headlamp and front fog lamp aiming (for Europe).....	7-88
Rear combination light bulb replacement.....	7-93
High mounted stop lamp replacement.....	7-96
License plate light bulb replacement .....	7-96
Interior light bulb replacement.....	7-97
<b>Appearance care</b> .....	<b>7-99</b>
Exterior care .....	7-99
Interior care .....	7-105

<b>Emission control system</b> .....	<b>7-108</b>
Crankcase emission control system.....	7-108
Evaporative emission control system .....	7-108
Exhaust emission control system.....	7-109
Selective Catalytic Reduction .....	7-113

## ENGINE COMPARTMENT

### ■ Gasoline Engine (1.6 GDI)

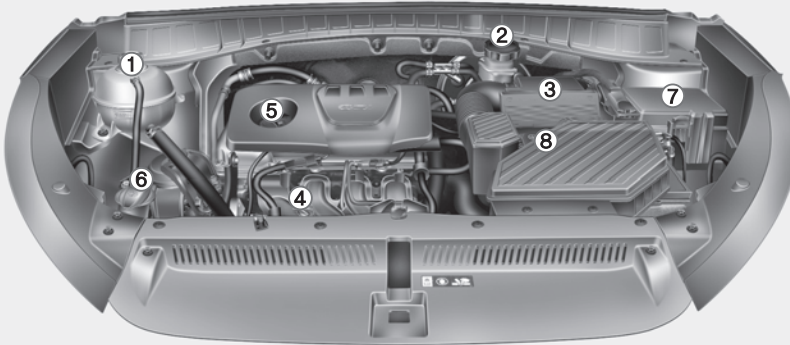

1. Engine coolant reservoir/Radiator cap
2. Brake/clutch fluid reservoir
3. Air cleaner
4. Engine oil dipstick
5. Engine oil filler cap
6. Windshield washer fluid reservoir
7. Fuse box
8. Battery

### ■ Gasoline Engine (1.6 T-GDI)

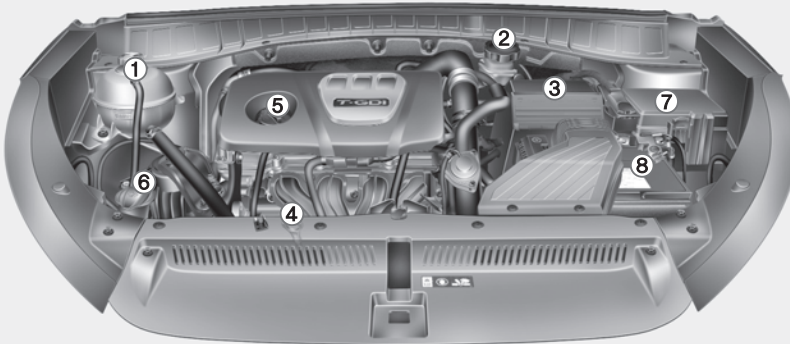

The actual engine room in the vehicle may differ from the illustration.

OTLE075001/OTLE075002

### ■ Gasoline Engine (2.0 MPI)

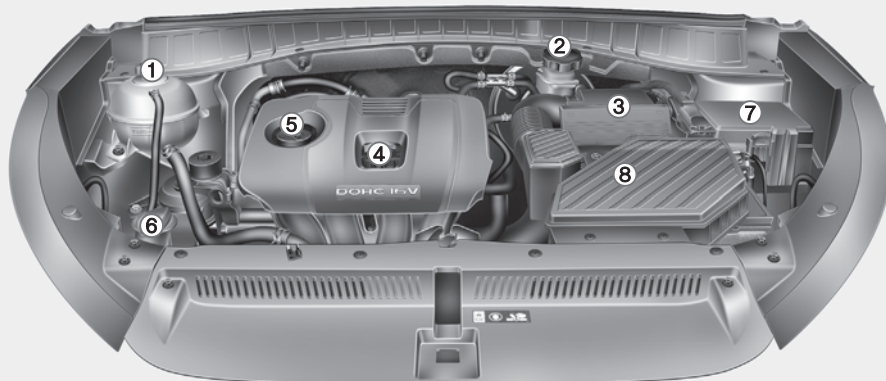

1. Engine coolant reservoir/Radiator cap
2. Brake/clutch fluid reservoir
3. Air cleaner
4. Engine oil dipstick
5. Engine oil filler cap
6. Windshield washer fluid reservoir
7. Fuse box
8. Battery

### ■ Gasoline Engine (2.4 GDI)

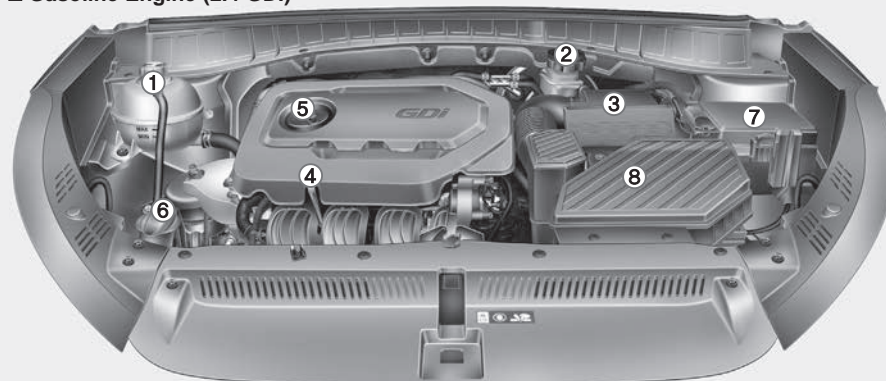

**The actual engine room in the vehicle may differ from the illustration.**

OTLE075003/OTLE075104

### ■ Diesel Engine (Smartstream D1.6 / Smartstream D1.6 48V MHEV)

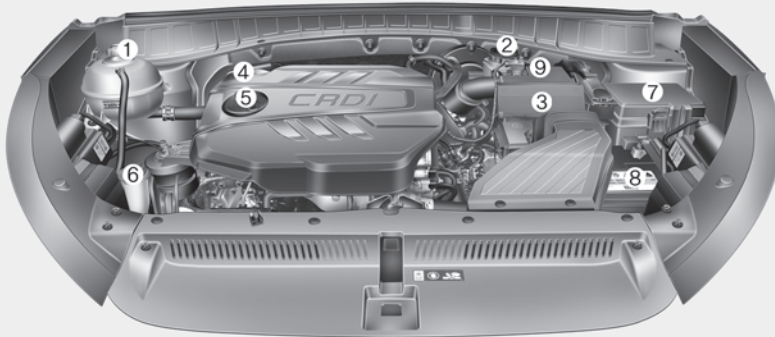

1. Engine coolant reservoir/Radiator cap
2. Brake/clutch fluid reservoir
3. Air cleaner
4. Engine oil dipstick
5. Engine oil filler cap
6. Windshield washer fluid reservoir
7. Fuse box
8. Battery
9. Fuel filter

### ■ Diesel Engine (2.0 TCI / 2.0 48V MHEV)

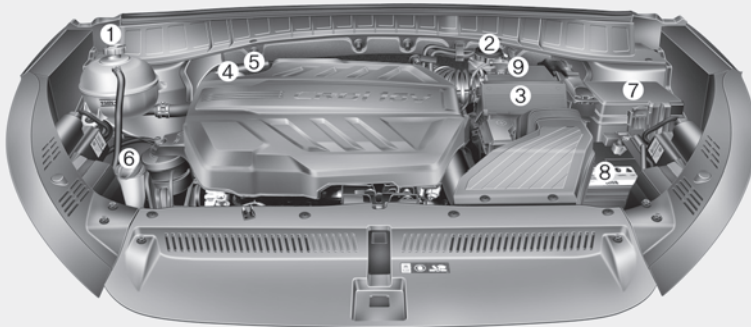

**The actual engine room in the vehicle may differ from the illustration.**

OTLE078002/OTLE078001



### MAINTENANCE SERVICES

You should exercise the utmost care to prevent damage to your vehicle and injury to yourself whenever performing any maintenance or inspection procedures.

We recommend you have your vehicle maintained and repaired by an authorized HYUNDAI dealer. An authorized HYUNDAI dealer meets HYUNDAI's high service quality standards and receives technical support from HYUNDAI in order to provide you with a high level of service satisfaction.

#### Owner's responsibility

Maintenance service and record retention are the owner's responsibility.

You should retain documents that show proper maintenance has been performed on your vehicle in accordance with the scheduled maintenance service charts shown on the following pages. You need this information to establish your compliance with the servicing and maintenance requirements of your vehicle warranties.

Detailed warranty information is provided in your Service Passport.

Repairs and adjustments required as a result of improper maintenance or a lack of required maintenance are not covered.

#### Owner maintenance precautions

Inadequate, incomplete or insufficient servicing may result in operational problems with your vehicle that could lead to vehicle damage, an accident, or personal injury. This chapter provides instructions only for the maintenance items that are easy to perform.

Several procedures can be done only by an authorized HYUNDAI dealer with special tools.

Your vehicle should not be modified in any way. Such modifications may adversely affect the performance, safety or durability of your vehicle and may, in addition, violate conditions of the limited warranties covering the vehicle.

#### **NOTICE**

**Improper owner maintenance during the warranty period may affect warranty coverage. For details, read the separate Service Passport provided with the vehicle. If you're unsure about any servicing or maintenance procedure, we recommend that the system be serviced by an authorized HYUNDAI dealer.**

## OWNER MAINTENANCE

### WARNING

Performing maintenance work on a vehicle can be dangerous. If you lack sufficient knowledge and experience or the proper tools and equipment to do the work, we recommend that the system be serviced by an authorized HYUNDAI dealer. ALWAYS follow these precautions for performing maintenance work:

- Park your vehicle on level ground, move the shift lever into the P (Park, for automatic transaxle/dual clutch transmission vehicle) position, apply the parking brake, place the ignition switch in the LOCK/OFF position.
- Block the tires (front and back) to prevent the vehicle from moving.

Remove loose clothing or jewelry that can become entangled in moving parts.

(Continued)

(Continued)

- If you must run the engine during maintenance, do so out doors or in an area with plenty of ventilation.
- Keep flames, sparks, or smoking materials away from the battery and fuel-related parts.

The following lists are vehicle checks and inspections that should be performed by the owner or an authorized HYUNDAI dealer at the frequencies indicated to help ensure safe, dependable operation of your vehicle.

Any adverse conditions should be brought to the attention of your dealer as soon as possible.

These Owner Maintenance vehicle checks are generally not covered by warranties and you may be charged for labor, parts and lubricants used.

### WARNING

#### Diesel Engine

Never manipulate or modify the injection system while running the diesel engine or within 30 seconds after turning OFF the diesel engine. The high-pressure pump, high-pressure pipes, rail, and injectors are still subject to the high pressure right after stopping the diesel engine.

When the fuel leakage vents out, it may cause serious body injury. Any people, who are implemented with the artificial cardiac pacemaker, should remain away from the ECU or the wiring harness by at least 30 cm, while running the diesel engine. The high currents of the electric engine control system produce a considerable amount of magnetic fields.

### Owner maintenance schedule

#### *When you stop for fuel:*

- Check the engine oil level.
- Check coolant level in the engine coolant reservoir.
- Check the windshield washer fluid level.
- Check for low or under-inflated tires.

#### **WARNING**

**Be careful when checking your engine coolant level when the engine is hot. This may result in coolant being blown out of the opening and cause serious burns and other injuries.**

#### *While operating your vehicle:*

- Note any changes in the sound of the exhaust or any smell of exhaust fumes in the vehicle.
- Check for vibrations in the steering wheel. Notice if there is any increased steering effort or looseness in the steering wheel, or change in its straight-ahead position.
- Notice if your vehicle constantly turns slightly or “pulls” to one side when traveling on smooth, level road.
- When stopping, listen and check for unusual sounds, pulling to one side, increased brake pedal travel or “hard-to-push” brake pedal.
- If any slipping or changes in the operation of your transaxle occurs, check the transaxle fluid level.
- Check the automatic transaxle/dual clutch transmission P (Park) function.
- Check the parking brake.
- Check for fluid leaks under your vehicle (water dripping from the air conditioning system during or after use is normal).

#### *At least monthly:*

- Check coolant level in the engine coolant reservoir.
- Check the operation of all exterior lights, including the stoplights, turn signals and hazard warning flashers.
- Check the inflation pressures of all tires including the spare for tires that are worn, show uneven wear, or are damaged.
- Check for loose wheel lug nuts.

***At least twice a year:  
(i.e., every Spring and Fall)***

- Check radiator, heater and air conditioning hoses for leaks or damage.
- Check windshield washer spray and wiper operation. Clean wiper blades with clean cloth dampened with washer fluid.
- Check headlamp alignment.
- Check muffler, exhaust pipes, shields and clamps.
- Check the seat belts for wear and function.

***At least once a year:***

- Clean body and door drain holes.
- Lubricate door hinges and hood hinges.
- Lubricate door and hood locks and latches.
- Lubricate door rubber weather strips.
- Check the air conditioning system.
- Inspect and lubricate automatic transaxle linkage and controls.
- Clean the battery and terminals.
- Check the brake fluid level.

### SCHEDULED MAINTENANCE SERVICES

Follow Normal Maintenance Schedule if the vehicle is usually operated where none of the following conditions apply. If any of the following conditions apply, you must follow the Maintenance Under Severe Usage Conditions.

- Repeated driving short distance of less than 8 km (5 miles) in normal temperature or less than 16 km (10 miles) in freezing temperature
- Extensive engine idling or low speed driving for long distances
- Driving on rough, dusty, muddy, unpaved, graveled or salt-spread roads
- Driving in areas using salt or other corrosive materials or in very cold weather
- Driving in the condition of inflowing sand or dust into engine
- Driving in heavy traffic area
- Driving on uphill, downhill, or mountain road repeatedly
- Towing a trailer or using a camper, or roof rack
- Driving as a patrol car, taxi, other commercial use of vehicle towing
- Driving over 170 km/h (106 mile/h)
- Frequently driving in stop-and-go condition

*If your vehicle is operated under the above conditions, you should inspect, replace or refill more frequently than the following Normal Maintenance Schedule. After the periods or distance shown in the chart, continue to follow the prescribed maintenance intervals.*

## Normal Maintenance Schedule (For Europe, Except Russia)

MAINTENANCE ITEM	MAINTENANCE INTERVALS		24	48	72	96	120	144	168	192
	Months		20	40	60	80	100	120	140	160
	Miles x 1,000		30	60	90	120	150	180	210	240
Drive belts (Gasoline) *1			First Inspect at 90,000 km (60,000 miles) or 72 months, after every 30,000 km (20,000 miles) or 24 months							
Drive belts (Diesel) *1	Smartstream D1.6		First Inspect at 90,000 km (60,000 miles) or 48 months, after every 30,000 km (20,000 miles) or 24 months							
	2.0 TCI		First Inspect at 90,000 km (60,000 miles) or 72 months, after every 30,000 km (20,000 miles) or 24 months							
MHEV (Mild Hybrid) belt	Smartstream D1.6 48V MHEV *1		First Inspect at 90,000 km (60,000 miles) or 48 months, after every 30,000 km (20,000 miles) or 24 months							
	2.0 48V MHEV *2		I	I	I	I	I	I	I	I
Timing belt	Smartstream D1.6/ 1.6 48V MHEV		Inspect every 120,000 km (80,000 miles), replace every 240,000 km (160,000 miles)							
Timing belt system (Oil belt, Tensioner, Idler)	Smartstream D1.6/ 1.6 48V MHEV		Replace every 240,000 km (160,000 miles)							

I : Inspect and if necessary, adjust, correct, clean or replace.

R : Replace or change.

\*1 : Inspect drive belt tensioner, idler and alternator pulley and if necessary correct or replace.

\*2 : Inspect drive belt tensioner, idler, alternator pulley, water pump drive belt and water pump pulley and if necessary correct or replace.

**Normal Maintenance Schedule (For Europe, Except Russia) (Cont.)**

MAINTENANCE ITEM	MAINTENANCE INTERVALS	Months	24	48	72	96	120	144	168	192
	Miles x 1,000	20	40	60	80	100	120	140	160	
	Km x 1,000	30	60	90	120	150	180	210	240	
Engine oil and engine oil filter *3	Diesel *4 *5 *6	R	R	R	R	R	R	R	R	R
	Gasoline (1.6 GDI) *4 *7	R	R	R	R	R	R	R	R	R
	Gasoline (1.6 T-GDI) *4	Replace every 15,000 km (10,000 miles) or 12 months								
	Gasoline (2.0 MPI) *4	Replace every 15,000 km (10,000 miles) or 12 months								
	Gasoline (2.4 GDI) *4	Replace every 15,000 km (10,000 miles) or 12 months								

I : Inspect and if necessary, adjust, correct, clean or replace.

R : Replace or change.

\*3 : The engine oil level should be checked regularly and maintained properly.

Operating with an insufficient amount of oil can damage the engine, and such damage is not covered by warranty.

\*4 : Check the engine oil level and leak every 500 km (350 miles) or before starting a long trip.

\*5 : This maintenance schedule depends on fuel quality. It is applicable only when using a qualified fuel <"EN590 or equivalent">. If the diesel fuel specifications don't meet the EN590, it must be replaced according to the severe maintenance schedule.

\*6 : If the recommended oil is not available, replace engine oil and engine oil filter every 20,000 km or 12 months.

\*7 : If the recommended oil is not available, replace engine oil and engine oil filter every 15,000 km.

## Normal Maintenance Schedule (For Europe, Except Russia) (Cont.)

MAINTENANCE ITEM	MAINTENANCE INTERVALS	Months	24	48	72	96	120	144	168	192
		Miles x 1,000	20	40	60	80	100	120	140	160
		Km x 1,000	30	60	90	120	150	180	210	240
Fuel additives (Gasoline) *8		Add every 15,000 km (10,000 miles) or 12 months								
Intercooler, in/out hose, air intake hose		1.6 T-GDI	Inspect every 10,000 km (6,500 miles)							
Air cleaner filter			I	R	I	R	I	R	I	R
Spark plugs		For 1.6 T-GDI	Replace every 75,000 km (50,000 miles) *9 or 60 months							
		Except 1.6 T-GDI	Replace every 160,000 km (100,000 miles) *9 or 120 months							
Vapor hose and fuel filler cap (Gasoline)			I		I		I		I	
Fuel tank air filter (Gasoline)			I		I		I		I	
Fuel filter (Gasoline) *10			I	I	I	I	I	I	I	I
Fuel lines, hoses and connections (Gasoline)			I		I		I		I	
Fuel lines, hoses and connections (Diesel)			I	I	I	I	I	I	I	I
Urea tube, connections (Diesel)			I	I	I	I	I	I	I	I
Urea cap (Diesel)			I	I	I	I	I	I	I	I

I : Inspect and if necessary, adjust, correct, clean or replace.

R : Replace or change.

\*8 : If good quality gasolines meet Europe Fuel standards (EN228) or equivalents including fuel additives is not available, one bottle of additive is recommended. Additives are available from your authorized HYUNDAI dealer along with information on how to use them. Do not mix other additives.

\*9 : For your convenience, it can be replaced prior to it's interval when you do maintenance of other items.

\*10 : The fuel filter is considered to be maintenance free but periodic inspection is recommended for this maintenance schedule depends on fuel quality. If there are some important matters like fuel flow restriction, surging, loss of power, hard starting problem etc, replace the fuel filter immediately regardless of maintenance schedule and consult an authorized HYUNDAI dealer for details.



**Normal Maintenance Schedule (For Europe, Except Russia) (Cont.)**

MAINTENANCE ITEM	MAINTENANCE INTERVALS	Months	24	48	72	96	120	144	168	192
		Miles x 1,000	20	40	60	80	100	120	140	160
		Km x 1,000	30	60	90	120	150	180	210	240
Fuel filter cartridge (Diesel) *11			I	R	I	R	I	R	I	R
Cooling system	Inspect "Coolant level adjustment and leak" every day. At first, inspect 60,000 km (40,000 miles) or 48 months after that, inspect every 30,000 km (20,000 miles) or 24 months									
Engine coolant *12	At first, replace at 210,000 km (120,000 miles) or 10 years : after that, replace every 30,000 km (20,000 miles) or 24 months *13									
Battery condition			I	I	I	I	I	I	I	I
Brake lines, hoses and connections			I	I	I	I	I	I	I	I
Parking brake			I	I	I	I	I	I	I	I
Brake/clutch fluid			R	R	R	R	R	R	R	R
Disc brakes and pads			I	I	I	I	I	I	I	I
Steering gear rack, linkage and boots			I	I	I	I	I	I	I	I

I : Inspect and if necessary, adjust, correct, clean or replace.

R : Replace or change.

\*11 : This maintenance schedule depends on fuel quality. It is applicable only when using a qualified fuel <"EN590 or equivalent">. If the diesel fuel specifications don't meet the EN590, it must be replaced more frequently. If there are some important safety matters like fuel flow restriction, surging, loss of power, hard starting problem etc., replace the fuel filter immediately regardless of maintenance schedule. We recommend that you consult an authorized HYUNDAI dealer for details.

\*12 : When adding coolant, use only deionized water or soft water for your vehicle and never mix hard water in the coolant filled at the factory. An improper coolant mixture can result in serious malfunction or engine damage.

\*13 : For your convenience, it can be replaced prior to it's interval when you do maintenance of other items.

## Normal Maintenance Schedule (For Europe, Except Russia) (Cont.)

MAINTENANCE ITEM	MAINTENANCE INTERVALS	Months	24	48	72	96	120	144	168	192
		Miles x 1,000	20	40	60	80	100	120	140	160
		Km x 1,000	30	60	90	120	150	180	210	240
Driveshaft and boots		I	I	I	I	I	I	I	I	I
Tire (pressure & tread wear)		I	I	I	I	I	I	I	I	I
Front suspension ball joints		I	I	I	I	I	I	I	I	I
Air conditioner refrigerant		I	I	I	I	I	I	I	I	I
Air conditioner compressor		I	I	I	I	I	I	I	I	I
Climate control air filter		R	R	R	R	R	R	R	R	R
Manual transaxle fluid <sup>*14</sup>			I		I		I		I	
Dual clutch transmission fluid <sup>*14</sup>			I		I		I		I	
Automatic transaxle fluid		No check, No service required								
Transfer case oil (4WD) <sup>*14</sup>			I		I		I		I	
Rear differential oil (4WD) <sup>*14</sup>			I		I		I		I	
Propeller shaft (4WD)		I	I	I	I	I	I	I	I	I
Valve clearance (Gasoline - 1.6 GDI, 1.6 T-GDI, 2.4 GDI) <sup>*15</sup>				I			I			
Exhaust system		I	I	I	I	I	I	I	I	I

I : Inspect and if necessary, adjust, correct, clean or replace.

R : Replace or change.

<sup>\*14</sup> : Manual transaxle/dual clutch transmission fluid, transfer case oil and differential oil should be changed anytime they have been submerged in water.

<sup>\*15</sup> : Inspect for excessive valve noise and/or engine vibration and adjust if necessary. We recommend that the system be checked by an authorized HYUNDAI dealer.

### Maintenance Under Severe Usage and Low Mileage Conditions (For Europe, Except Russia)

The following items must be serviced more frequently on cars mainly used under severe and low mileage driving conditions. Refer to the chart below for the appropriate maintenance intervals.

R : Replace or change. I : Inspect and if necessary, adjust, correct, clean or replace.

Maintenance item		Maintenance operation	Maintenance intervals	Driving condition
Engine oil and engine oil filter	Diesel	R	Every 15,000 km (10,000 miles) or 12 months	A, B, C, D, E, F, G, H, I, K, L
	Gasoline (1.6 GDI)			
	Gasoline (1.6 T-GDI)/		Every 7,500 km (4,500 miles) or 6 months	
	Gasoline (2.0 MPI)/ Gasoline (2.4 GDI)			
Air cleaner filter		R	Replace more frequently depending on the condition	C, E
Spark plugs		R	Replace more frequently depending on the condition	A, B, F, G, H, I, K
Steering gear rack, linkage and boots		I	Inspect more frequently depending on the condition	C, D, E, F, G
Front suspension ball joints		I	Inspect more frequently depending on the condition	C, D, E, F, G
Disc brakes and pads, calipers and rotors		I	Inspect more frequently depending on the condition	C, D, E, G, H
Parking brake		I	Inspect more frequently depending on the condition	C, D, G, H
Driveshaft and boots		I	Inspect more frequently depending on the condition	C, D, E, F, G, H, I

Maintenance item	Maintenance operation	Maintenance intervals	Driving condition
Climate control air filter	R	Replace more frequently depending on the condition	C, E, G
Manual transaxle fluid	R	Every 120,000 km (80,000 miles)	C, D, E, F, G, H, I, K
Automatic transaxle fluid	R	Every 100,000 km (62,000 miles)	A, C, D, E, F, G, H, I, K
Dual clutch transmission fluid	R	Every 120,000 km (80,000 miles)	C, D, E, G, H, I, K
Rear differential oil (4WD)	R	Every 120,000 km (80,000 miles)	C, D, E, G, I, K, H
Transfer case oil (4WD)	R	Every 120,000 km (80,000 miles)	C, D, E, G, I, K, H
Propeller shaft (4WD)	I	Every 20,000 km (12,500 miles) or 12 months	C, E

### Severe driving conditions

- A : Repeatedly driving short distance of less than 8 km (5 miles) in normal temperature or less than 16 km (10 miles) in freezing temperature
- B : Extensive engine idling or low speed driving for long distances
- C : Driving on rough, dusty, muddy, unpaved, graveled or salt spread roads
- D : Driving in areas using salt or other corrosive materials or in very cold weather

- E : Driving in the condition of inflowing sand or dust into engine
- F : Driving in heavy traffic area
- G : Driving on uphill, downhill, or mountain roads repeatedly
- H : Towing a trailer, or using a camper or roof rack
- I : Driving for patrol car, taxi, commercial car or vehicle towing
- J : Driving over 140 km/h (87 mile/h)
- K : Driving over 170 km/h (106 mile/h)
- L : Frequently driving in stop-and-go conditions and under 15,000 km per year.

**Normal Maintenance Schedule (Except Europe, For Russia)**

MAINTENANCE ITEM	MAINTENANCE INTERVALS		Months	12	24	36	48	60	72	84	96
			Miles x 1,000	10	20	30	40	50	60	70	80
			Km x 1,000	15	30	45	60	75	90	105	120
Drive belts *1	Gasoline			I			I		I		I
	Diesel (For Russia, Australia, New Zealand)		First Inspect at 90,000 km (60,000 miles) or 48 months, after every 30,000 km (20,000 miles) or 24 months								
	Diesel (Except Europe, Russia, Australia, New Zealand)		First Inspect at 80,000 km (50,000 miles) or 48 months, after every 20,000 km (12,500 miles) or 12 months								
MHEV (Mild Hybrid) belt	Smartstream D1.6 48V MHEV *1	For Russia	First Inspect at 90,000 km (60,000 miles) or 48 months, after every 30,000 km (20,000 miles) or 24 months								
		Except Russia	First Inspect at 80,000 km (50,000 miles) or 48 months, after every 20,000 km (12,500 miles) or 12 months								
	2.0 48V MHEV *2		I	I	I	I	I	I	I	I	I
Timing belt	Smartstream D1.6/ 1.6 48V MHEV		Inspect every 120,000 km (80,000 miles), replace every 240,000 km (160,000 miles)								
Timing belt system (Oil belt, Tensioner, Idler)	Smartstream D1.6/ 1.6 48V MHEV		Replace every 240,000 km (160,000 miles)								

I : Inspect and if necessary, adjust, correct, clean or replace.

R : Replace or change.

\*1 : Inspect drive belt tensioner, idler and alternator pulley and if necessary correct or replace.

\*2 : Inspect drive belt tensioner, idler, alternator pulley, water pump drive belt and water pump pulley and if necessary correct or replace.

## Normal Maintenance Schedule (Except Europe, For Russia) (Cont.)

MAINTENANCE ITEM	MAINTENANCE INTERVALS	Months	12	24	36	48	60	72	84	96
		Miles x 1,000	10	20	30	40	50	60	70	80
		Km x 1,000	15	30	45	60	75	90	105	120
Engine oil and engine oil filter * <sup>3</sup>	Diesel * <sup>4</sup> - For Russia	Replace every 15,000 km (10,000 miles) or 12 months								
	Diesel * <sup>4</sup> - Except Russia	Replace every 10,000 km (6,500 miles) or 12 months								
	Gasoline (1.6 GDI, 2.0 MPI, 2.4 GDI) - Except Middle East, Morocco, Egypt * <sup>4</sup>	R	R	R	R	R	R	R	R	R
	Gasoline (1.6 GDI, 2.0 MPI, 2.4 GDI) - For Middle East, Morocco, Egypt * <sup>4</sup>	Replace every 10,000 km (6,500 miles) or 12 months								
	Gasoline (1.6 T-GDI) - For South Africa * <sup>4</sup>	R	R	R	R	R	R	R	R	R
	Gasoline (1.6 T-GDI) - Except South Africa * <sup>4</sup>	Replace every 10,000 km (6,500 miles) or 12 months								

I : Inspect and if necessary, adjust, correct, clean or replace.

R : Replace or change.

\*<sup>3</sup> : The engine oil level should be checked regularly and maintained properly.

Operating with an insufficient amount of oil can damage the engine, and such damage is not covered by warranty.

\*<sup>4</sup> : Check the engine oil level and leak every 500 km (350 miles) or before starting a long trip.

**Normal Maintenance Schedule (Except Europe, For Russia) (Cont.)**

MAINTENANCE ITEM	MAINTENANCE INTERVALS	Months	12	24	36	48	60	72	84	96
		Miles x 1,000	10	20	30	40	50	60	70	80
		Km x 1,000	15	30	45	60	75	90	105	120
Fuel additives (Gasoline) *5		Add every 10,000 km (6,500 miles) or 6 months								
Intercooler, in/out hose, air intake hose	1.6 T-GDI	Inspect every 10,000 km (6,500 miles)								
Air cleaner filter	Except Middle East	I	I	R	I	I	R	I	I	
	For Middle East	R	R	R	R	R	R	R	R	
Spark plugs	For 1.6 T-GDI	Replace every 75,000 km (50,000 miles) *6 or 60 months								
	Except 1.6 T-GDI	Replace every 160,000 km (100,000 miles) *6 or 120 months								
Vapor hose and fuel filler cap (Gasoline)					I				I	
Fuel tank air filter (Gasoline)			I		R		I		R	
Fuel filter (Gasoline) *7			I		R		I		R	
Fuel lines, hoses and connections (Gasoline)					I				I	
Fuel lines, hoses and connections (Diesel)			I		I		I		I	

I : Inspect and if necessary, adjust, correct, clean or replace.

R : Replace or change.

\*5 : If good quality gasolines meet Europe Fuel standards (EN228) or equivalents including fuel additives is not available, one bottle of additive is recommended. Additives are available from your authorized HYUNDAI dealer along with information on how to use them. Do not mix other additives.

\*6 : For your convenience, it can be replaced prior to it's interval when you do maintenance of other items.

\*7 : The fuel filter is considered to be maintenance free but periodic inspection is recommended for this maintenance schedule depends on fuel quality. If there are some important matters like fuel flow restriction, surging, loss of power, hard starting problem etc, replace the fuel filter immediately regardless of maintenance schedule. We recommend that you consult an authorized HYUNDAI dealer for details.

## Normal Maintenance Schedule (Except Europe, For Russia) (Cont.)

MAINTENANCE ITEM	MAINTENANCE INTERVALS	Months	12	24	36	48	60	72	84	96
		Miles x 1,000	10	20	30	40	50	60	70	80
		Km x 1,000	15	30	45	60	75	90	105	120
Fuel filter cartridge (Diesel) *8				I		R		I		R
Cooling system		Inspect "Coolant level adjustment and leak" every day. At first, inspect 60,000 km (40,000 miles) or 48 months after that, inspect every 30,000 km (20,000 miles) or 24 months								
Engine coolant *9		At first, replace at 200,000 km (120,000 miles) or 120 months : after that, replace every 40,000 km (25,000 miles) or 24 months *6								
Battery condition		Except Middle East	I	I	I	I	I	I	I	I
		For Middle East	Inspect 10,000 km (6,200 miles) or 6 months							
Brake lines, hoses and connections			I	I	I	I	I	I	I	I
Parking brake			I	I	I	I	I	I	I	I
Brake/clutch fluid			I	I	I	I	I	I	I	I
Disc brakes and pads			I	I	I	I	I	I	I	I

I : Inspect and if necessary, adjust, correct, clean or replace.

R : Replace or change.

\*6 : For your convenience, it can be replaced prior to it's interval when you do maintenance of other items.

\*8 : This maintenance schedule depends on fuel quality. It is applicable only when using a qualified fuel <"EN590 or equivalent">. If the diesel fuel specifications don't meet the EN590, it must be replaced more frequently. HYUNDAI recommends "every 7,500km inspection, every 15,000km replacement". If there are some important safety matters like fuel flow restriction, surging, loss of power, hard starting problem etc., replace the fuel filter immediately regardless of maintenance schedule. We recommend that you consult an authorized HYUNDAI dealer for details.

\*9 : When adding coolant, use only deionized water or soft water for your vehicle and never mix hard water in the coolant filled at the factory. An improper coolant mixture can result in serious malfunction or engine damage. For your convenience, it can be replaced prior to it's interval when you do maintenance of other items.



**Normal Maintenance Schedule (Except Europe, For Russia) (Cont.)**

MAINTENANCE ITEM	MAINTENANCE INTERVALS		Months	12	24	36	48	60	72	84	96
			Miles x 1,000	10	20	30	40	50	60	70	80
			Km x 1,000	15	30	45	60	75	90	105	120
Steering gear rack, linkage and boots			I	I	I	I	I	I	I	I	I
Driveshaft and boots				I		I		I		I	I
Tire (pressure & tread wear)			I	I	I	I	I	I	I	I	I
Front suspension ball joints			I	I	I	I	I	I	I	I	I
Air conditioner refrigerant			I	I	I	I	I	I	I	I	I
Air conditioner compressor			I	I	I	I	I	I	I	I	I
Climate control air filter			R	R	R	R	R	R	R	R	R
Manual transaxle fluid *10						I					I
Dual clutch transmission fluid *10						I					I
Automatic transaxle fluid	Except Middle East	No check, No service required									
	For Middle East		I		I		I		I		I
Transfer case oil (4WD) *10						I					I
Rear differential oil (4WD) *10						I					I
Propeller shaft (4WD)				I		I		I		I	I
Valve clearance (Gasoline - 1.6 GDI, 1.6 T-GDI, 2.4 GDI) *11								I			
Exhaust system				I		I		I		I	I

I : Inspect and if necessary, adjust, correct, clean or replace.

R : Replace or change.

\*10 : Manual transaxle/Dual clutch transmission fluid, transfer case oil and differential oil should be changed anytime they have been submerged in water.

\*11 : Inspect for excessive valve noise and/or engine vibration and adjust if necessary. We recommend that the system be checked by an authorized HYUNDAI dealer.

## Maintenance Under Severe Usage and Low Mileage Conditions (Except Europe, For Russia)

The following items must be serviced more frequently on cars mainly used under severe driving conditions.

Refer to the chart below for the appropriate maintenance intervals.

R : Replace or change. I : Inspect and if necessary, adjust, correct, clean or replace.

Maintenance item		Maintenance operation	Maintenance intervals	Driving condition
Engine oil and engine oil filter	Diesel - For Russia	R	Every 7,500 km (4,500 miles) or 6 months	A, B, C, D, E, F, G, H, I, K, L
	Diesel - Except Russia		Every 5,000 km (3,000 miles) or 6 months	
	Gasoline (1.6 GDI, 2.0 MPI, 2.4 GDI) - Except Middle East, Morocco, Egypt		Every 7,500 km (4,500 miles) or 6 months	
	Gasoline (1.6 GDI, 2.0 MPI, 2.4 GDI) - For Middle East, Morocco, Egypt		Every 5,000 km (3,000 miles) or 6 months	
	Gasoline (1.6 T-GDI) - For South Africa		Every 7,500 km (4,500 miles) or 6 months	
	Gasoline (1.6 T-GDI) - Except South Africa		Every 5,000 km (3,000 miles) or 6 months	
Air cleaner filter		R	Replace more frequently depending on the condition	C, E
Spark plugs		R	Replace more frequently depending on the condition	A, B, F, G, H, I, K
Steering gear rack, linkage and boots		I	Inspect more frequently depending on the condition	C, D, E, F, G

Maintenance item	Maintenance operation	Maintenance intervals	Driving condition
Front suspension ball joints	I	Inspect more frequently depending on the condition	C, D, E, F, G
Disc brakes and pads, calipers and rotors	I	Inspect more frequently depending on the condition	C, D, E, G, H
Parking brake	I	Inspect more frequently depending on the condition	C, D, G, H
Driveshaft and boots	I	Inspect more frequently depending on the condition	C, D, E, F, G, H, I, K
Climate control air filter	R	Replace more frequently depending on the condition	C, E, G
Manual transaxle fluid	R	Every 120,000 km (80,000 miles)	C, D, E, F, G, H, I, K
Automatic transaxle fluid	R	Every 100,000 km (62,000 miles)	A, C, F, G, H, I, K
Dual clutch transmission fluid	R	Every 120,000 km (80,000 miles)	C, D, E, G, H, I, K
Rear differential oil (4WD)	R	Every 120,000 km (80,000 miles)	C, D, E, G, I, K, H
Transfer case oil (4WD)	R	Every 120,000 km (80,000 miles)	C, D, E, G, I, K, H
Propeller shaft (4WD)	I	Every 15,000 km (10,000 miles) or 12 months	C, E

## Severe driving conditions

- A : Repeatedly driving short distance of less than 8 km (5 miles) in normal temperature or less than 16 km (10 miles) in freezing temperature
- B : Extensive engine idling or low speed driving for long distances
- C : Driving on rough, dusty, muddy, unpaved, graveled or salt spread roads
- D : Driving in areas using salt or other corrosive materials or in very cold weather
- E : Driving in the condition of inflowing sand or dust into engine
- F : Driving in heavy traffic area
- G : Driving on uphill, downhill, or mountain roads repeatedly
- H : Towing a trailer, or using a camper or roof rack
- I : Driving for patrol car, taxi, commercial car or vehicle towing
- J : Driving over 140 km/h (87 mile/h)
- K : Driving over 170 km/h (106 mile/h)
- L : Frequently driving in stop-and-go conditions

## EXPLANATION OF SCHEDULED MAINTENANCE ITEMS

### Engine oil and filter

The engine oil and filter should be changed at the intervals specified in the maintenance schedule. If the car is being driven in severe conditions, more frequent oil and filter changes are required.

### Drive belts

Inspect all drive belts for evidence of cuts, cracks, excessive wear or oil saturation and replace if necessary. Drive belts should be checked periodically for proper tension and adjusted as necessary.

#### CAUTION

**When you are inspecting the belt, place the ignition switch to the LOCK/OFF or ACC position.**

### Fuel filter (cartridge)

A clogged-up fuel filter may limit the vehicle driving speed, damage the emission system, and cause the hard starting. When a considerable amount of foreign substances are accumulated in the fuel tank, the fuel filter should be replaced.

Upon installing a new fuel filter, operate the diesel engine for several minutes, and check the connections for any leakages. We recommend you to have the fuel filter replaced by an authorized HYUNDAI dealer.

### Fuel lines, fuel hoses and connections

Check the fuel lines, fuel hoses and connections for leakage and damage. We recommend that the fuel lines, fuel hoses and connections be replaced by an authorized HYUNDAI dealer.

#### WARNING

### Diesel Engine

**Never manipulate or modify the injection system while running the diesel engine or within 30 seconds after turning OFF the diesel engine. The high-pressure pump, high-pressure pipes, rail, and injectors are still subject to the high pressure right after stopping the diesel engine. When the fuel leakage vents out, it may cause serious body injury. Any people, who are implemented with the artificial cardiac pacemaker, should remain away from the ECU or the wiring harness by at least 30 cm while running the diesel engine. The high currents of the common rail system produce a considerable amount of magnetic fields.**

## Vapor hose and fuel filler cap

The vapor hose and fuel filler cap should be inspected at those intervals specified in the maintenance schedule. Make sure that a new vapor hose or fuel filler cap is correctly replaced.

## Vacuum crankcase ventilation hoses (if equipped)

Inspect the surface of hoses for evidence of heat and/or mechanical damage. Hard and brittle rubber, cracking, tears, cuts, abrasions, and excessive swelling indicate deterioration. Particular attention should be paid to examine those hose surfaces nearest to high heat sources, such as the exhaust manifold.

Inspect the hose routing to assure that the hoses do not come in contact with any heat source, sharp edges or moving component which might cause heat damage or mechanical wear. Inspect all hose connections, such as clamps and couplings, to make sure they are secure, and that no leaks are present.

Hoses should be replaced immediately if there is any evidence of deterioration or damage.

## Air cleaner filter

We recommend that the air cleaner filter be replaced by an authorized HYUNDAI dealer.

## Spark plugs (For Gasoline Engine)

Make sure to install new spark plugs of the correct heat range.

### WARNING

**Do not disconnect and inspect spark plugs when the engine is hot. You may burn yourself.**

## Valve clearance (For Gasoline Engine - 1.6 GDI, 1.6 T-GDI, 2.4 GDI)

Inspect excessive valve noise and/or engine vibration and adjust if necessary. We recommend that the system be serviced by an authorized HYUNDAI dealer.

## Cooling system

Check the cooling system parts, such as radiator, coolant reservoir, hoses and connections for leakage and damage. Replace any damaged parts.

## Engine coolant

The coolant should be changed at the intervals specified in the maintenance schedule.

## Automatic transaxle fluid

Automatic transaxle fluid should not be checked under normal usage conditions.

We recommend that the automatic transaxle fluid be changed by an authorized HYUNDAI dealer according to the maintenance schedule.

### Information

**Automatic transaxle fluid color is basically red.**

**As the vehicle is driven, the automatic transaxle fluid will begin to look darker.**

**It is normal condition and you should not judge the need to replace the fluid based upon the changed color.**

### NOTICE

**The use of a non-specified fluid could result in transaxle malfunction and failure.**

**Use only specified automatic transaxle fluid.**  
(Refer to “Recommended lubricants and capacities” in chapter 8.)

### Manual transaxle fluid (if equipped)

Inspect the manual transaxle fluid according to the maintenance schedule.

### Dual clutch transmission fluid (if equipped)

Inspect the dual clutch transmission fluid according to the maintenance schedule.

### Brake hoses and lines

Visually check for proper installation, chafing, cracks, deterioration and any leakage. Replace any deteriorated or damaged parts immediately.

### Brake/Clutch fluid (if equipped)

Check brake fluid level in the brake fluid reservoir. The level should be between “MIN” and “MAX” marks on the side of the reservoir. Use only hydraulic brake fluid conforming to DOT 3 or DOT 4 specification.

### Parking brake

Inspect the parking brake system including the parking brake lever and cables.

### Brake pads, calipers and rotors

Check the pads for excessive wear, discs for run out and wear, and calipers for fluid leakage.

For more details on checking the pads or lining wear limit, refer to the HYUNDAI web site.

(<http://service.hyundai-motor.com>)

### Suspension mounting bolts

Check the suspension connections for looseness or damage. Retighten to the specified torque.

### Steering gear box, linkage & boots/lower arm ball joint

With the vehicle stopped and engine off, check for excessive free-play in the steering wheel.

Check the linkage for bends or damage. Check the dust boots and ball joints for deterioration, cracks, or damage. Replace any damaged parts.

### Drive shafts and boots

Check the drive shafts, boots and clamps for cracks, deterioration, or damage. Replace any damaged parts and, if necessary, repack the grease.

### Air conditioning refrigerant/compressor

Check the air conditioning lines and connections for leakage and damage.

## ENGINE OIL

### Checking the engine oil level (Gasoline engine)

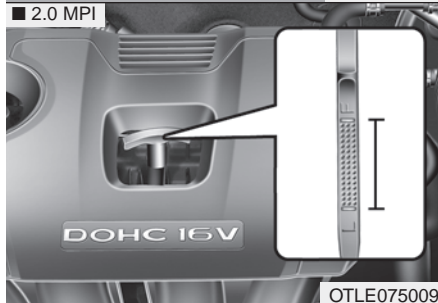
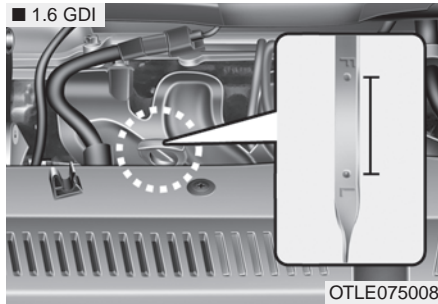

1. Be sure the vehicle is on level ground.
2. Start the engine and allow it to reach normal operating temperature.

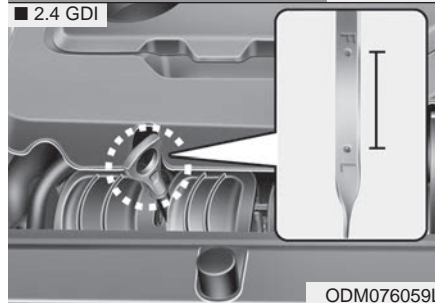
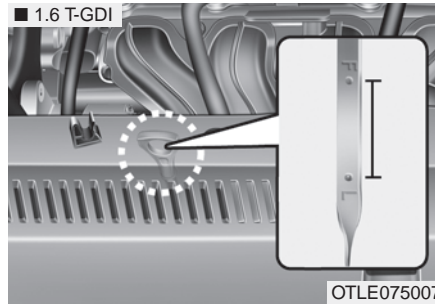

3. Turn the engine off and wait for a few minutes (about 5 minutes) for the oil to return to the oil pan.
4. Pull the dipstick out, wipe it clean, and re-insert it fully.

5. Pull the dipstick out again and check the level. The level should be between F (Full) and L (Low).
6. If it is near or at L, add enough oil to bring the level to F.

#### WARNING

##### Radiator hose

Be very careful not to touch the radiator hose when checking or adding the engine oil as it may be hot enough to burn you.

#### NOTICE

- Do not overfill the engine oil. It may damage the engine.
- Do not spill engine oil, when adding or changing engine oil. If you drop the engine oil on the engine room, wipe it off immediately.
- When you wipe the oil level gauge, you should wipe it with a clean cloth. When mixed with debris, it can cause engine damage.



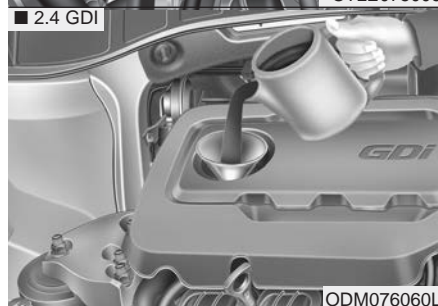
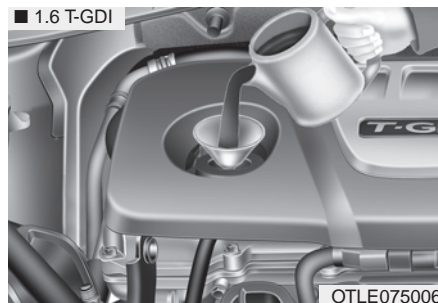
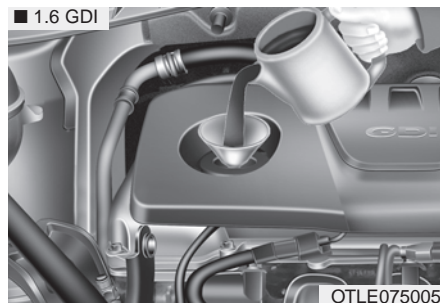

Use only the specified engine oil.  
(Refer to “Recommended lubricants and capacities” in chapter 8.)

## Checking the engine oil level (Diesel engine)

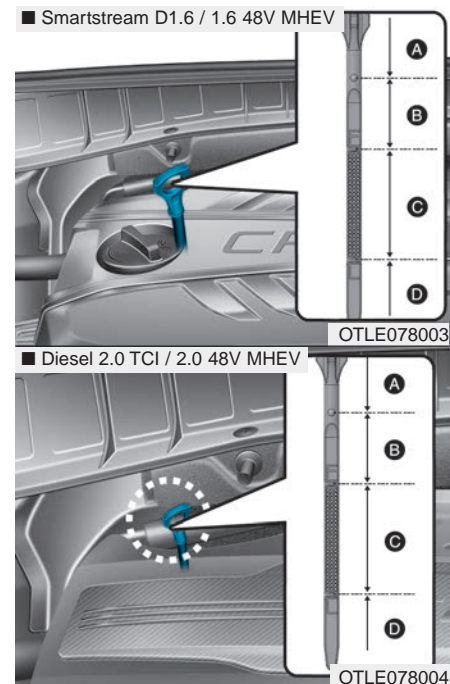

Figure	Required action
Range (A)	Recommend to contact an authorized HYUNDAI dealer
Range (B)	Do not refill engine oil.
Range (C)	Normal. You may add engine oil as long as the oil level does not go above the C range.
Range (D)	You must add oil and make sure that the oil level is in the C Range.

1. Be sure the vehicle is on level ground.
2. Start the engine and allow it to reach normal operating temperature.
3. Turn the engine off and wait for a few minutes (about 5 minutes) for the oil to return to the oil pan.
4. Pull the dipstick out, wipe it clean, and re-insert it fully.
5. Pull the dipstick out again and check the level.
6. The level should be in the C range. If the level is in the D range, add enough engine oil to bring the level up to the C range.

## WARNING

### Radiator hose

**Be very careful not to touch the radiator hose when checking or adding the engine oil as it may be hot enough to burn you.**

### NOTICE

- **Do not spill engine oil, when adding or changing engine oil. If you drop the engine oil on the engine room, wipe it off immediately.**
- **When you wipe the oil level gauge, you should wipe it with a clean cloth. When mixed with debris, it can cause engine damage.**

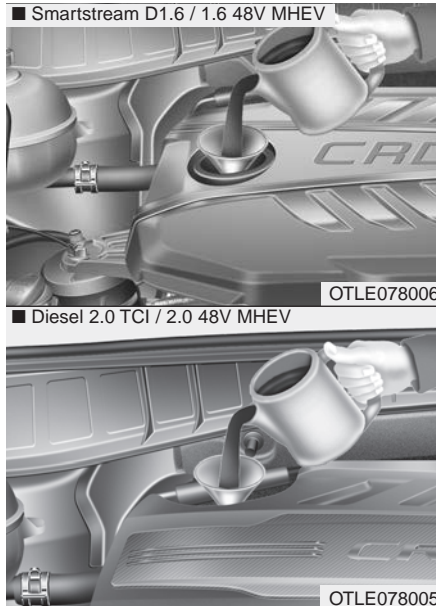

Use only the specified engine oil.  
(Refer to “Recommended lubricants and capacities” in chapter 8.)

### Checking the engine oil and filter



We recommend that the engine oil and filter be replaced by an authorized HYUNDAI dealer.

### ⚠ WARNING

Used engine oil may cause irritation or cancer of the skin if left in contact with the skin for prolonged periods of time. Used engine oil contains chemicals that have caused cancer in laboratory animals. Always protect your skin by washing your hands thoroughly with soap and warm water as soon as possible after handling used oil.

## ENGINE COOLANT

The high-pressure cooling system has a reservoir filled with year-round antifreeze coolant. The reservoir is filled at the factory.

Check the antifreeze protection and coolant concentration level at least once a year, at the beginning of the winter season, and before traveling to a colder climate.

### NOTICE

- **When the engine overheats from low engine coolant, suddenly adding engine coolant may cause cracks in the engine. To prevent damage, add engine coolant slowly in small quantities.**
- **Do not drive with no engine coolant. It may cause water pump failure and engine seizure, etc.**

### Checking the engine coolant level

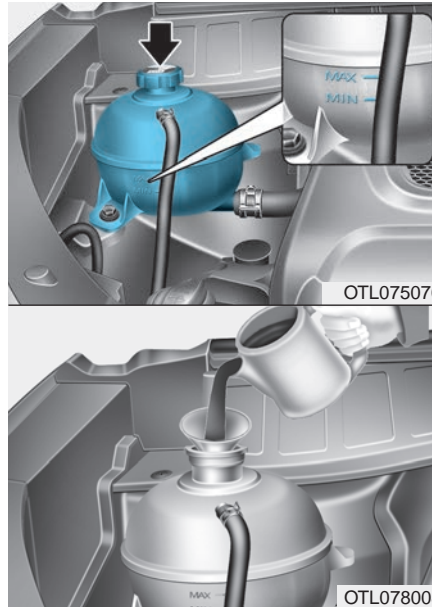

Check the condition and connections of all cooling system hoses and heater hoses. Replace any swollen or deteriorated hoses.

The coolant level should be filled between MAX and MIN marks on the side of the coolant reservoir when the engine is cool.

If the coolant level is low, add enough distilled (deionized) or soft water. Bring the level to MAX, but do not overfill.

If frequent additions are required, we recommend that the system be inspected by an authorized HYUNDAI dealer.

**⚠ WARNING**



**Removing radiator cap**

- Never attempt to remove the radiator cap while the engine is operating or hot. Doing so might lead to cooling system and engine damage and could result in serious personal injury from escaping hot coolant or steam.

(Continued)

(Continued)

- Turn the engine off and wait until it cools down. Use extreme care when removing the radiator cap. Wrap a thick towel around it, and turn it counterclockwise slowly to the first stop. Step back while the pressure is released from the cooling system.

When you are sure all the pressure has been released, press down on the cap, using a thick towel, and continue turning counterclockwise to remove it.

- Even if the engine is not operating, do not remove the radiator cap or the drain plug while the engine and radiator are hot. Hot coolant and steam may still blow out under pressure, causing serious injury.

**⚠ WARNING**



The electric motor (cooling fan) is controlled by engine coolant temperature, refrigerant pressure and vehicle speed. It may sometimes operate even when the engine is not running. Use extreme caution when working near the blades of the cooling fan so that you are not injured by a rotating fan blades. As the engine coolant temperature decreases, the electric motor will automatically shut off. This is a normal condition.

The electric motor (cooling fan) may operate until you disconnect the negative battery cable.

## NOTICE

Make sure the coolant cap is properly closed after refill of coolant. Otherwise the engine could be overheated while driving.

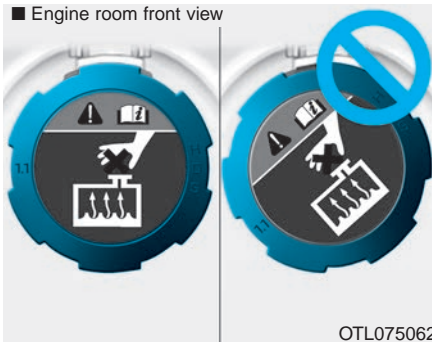

1. Check if the radiator cap label is straight in front.

(Continued)

(Continued)

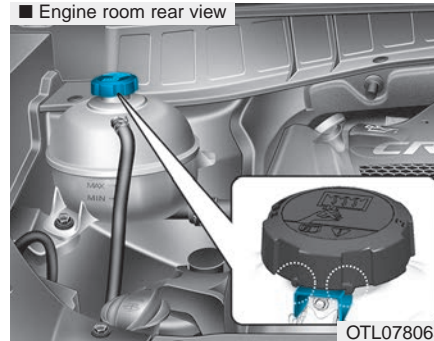

2. Make sure that the tiny protrusions inside the coolant cap should be securely interlocked.

## Recommended engine coolant

- When adding coolant, use only deionized water or soft water for your vehicle and never mix hard water in the coolant filled at the factory. An improper coolant mixture can result in serious malfunction or engine damage.
- The engine in your vehicle has aluminum engine parts and must be protected by an Phosphate-based Ethylene glycol coolant to prevent corrosion and freezing.
- DO NOT USE alcohol or methanol coolant or mix them with the specified coolant.
- Do not use a solution that contains more than 60% antifreeze or less than 35% antifreeze, which would reduce the effectiveness of the solution.

For mixture percentage, refer to the following table.

Ambient Temperature	Mixture Percentage (volume)	
	Antifreeze	Water
-15°C (5°F)	35	65
-25°C (-13°F)	40	60
-35°C (-31°F)	50	50
-45°C (-49°F)	60	40

### **i** Information

If in doubt about the mix ratio, a 50% water and 50% antifreeze mix is the easiest to mix together as it will be the same quantity of each. It is suitable to use for most temperature ranges of -35°C (-31°F) and higher.

### Changing the engine coolant

We recommend that the coolant be replaced by an authorized HYUNDAI dealer.

#### **NOTICE**

Put a thick cloth or fabric around the radiator cap before refilling the coolant in order to prevent the coolant from overflowing into engine parts such as generator.

#### **⚠ WARNING**

- Do not use engine coolant or antifreeze in the washer fluid reservoir.
- Engine coolant can severely obscure visibility when sprayed on the windshield and may cause loss of vehicle control or damage to paint and body trim.

## BRAKE/CLUTCH FLUID (IF EQUIPPED)

### Checking the brake/clutch fluid level

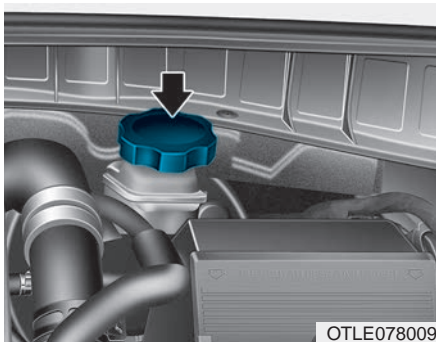

Check the fluid level in the reservoir periodically. The fluid level should be between MAX and MIN marks on the side of the reservoir.

Before removing the reservoir cap and adding brake/clutch fluid, clean the area around the reservoir cap thoroughly to prevent brake/clutch fluid contamination.

If the level is low, add fluid to the MAX level. The level will fall with accumulated mileage. This is a normal condition associated with the wear of the brake linings.

If the fluid level is excessively low, we recommend that the system be checked by an authorized HYUNDAI dealer.

#### **i** Information

Use only the specified brake/clutch fluid. (Refer to “Recommended lubricants and capacities” in chapter 8.)

#### **!** WARNING

In the event the brake/clutch system requires frequent additions of fluid, we recommend that the system be inspected by an authorized HYUNDAI dealer.

#### **i** Information

Before removing the brake/clutch filler cap, read the warning on the cap.

#### **i** Information

Clean filler cap before removing. Use only DOT3 or DOT4 brake/clutch fluid from a sealed container.

#### **!** WARNING

When changing and adding brake/clutch fluid, handle it carefully. Do not let it come in contact with your eyes. If brake/clutch fluid should come in contact with your eyes, immediately flush them with a large quantity of fresh tap water. Have your eyes examined by a doctor as soon as possible.

#### **NOTICE**

Do not allow brake/clutch fluid to contact the vehicle's body paint, as paint damage will result.

Brake/clutch fluid, which has been exposed to open air for an extended time should never be used as its quality cannot be guaranteed. It should be disposed of properly. Don't put in the wrong kind of fluid.

A few drops of mineral-based oil, such as engine oil, in your brake/clutch system can damage brake/clutch system parts.



## WASHER FLUID

### Checking the washer fluid level

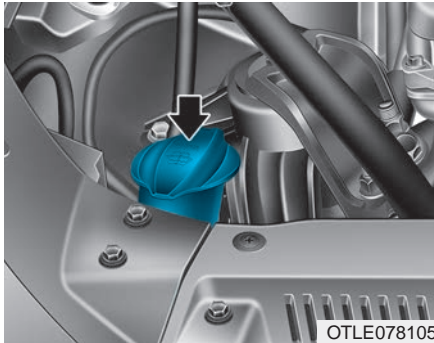

The reservoir is translucent so that you can check the level with a quick visual inspection.

Check the fluid level in the washer fluid reservoir and add fluid if necessary.

Plain water may be used if washer fluid is not available.

However, use washer solvent with antifreeze characteristics in cold climates to prevent freezing.

#### NOTICE

Do not use engine coolant or antifreeze in the washer fluid reservoir.

#### ⚠ WARNING

- Engine coolant can severely obscure visibility when sprayed on the windshield and may cause loss of vehicle control or damage to paint and body trim.
- Windshield Washer fluid agents contain some amounts of alcohol and can be flammable under certain circumstances. Do not allow sparks or flame to contact the washer fluid or the washer fluid reservoir. Damage to the vehicle or occupants could occur.
- Windshield washer fluid is poisonous to humans and animals. Do not drink and avoid contacting windshield washer fluid. Serious injury or death could occur.

## PARKING BRAKE

### Checking the parking brake

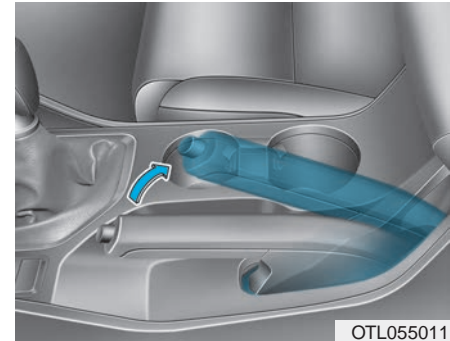

Check the stroke of the parking brake by counting the number of “clicks” heard while fully applying it from the released position. Also, the parking brake alone should securely hold the vehicle on a fairly steep grade. If the stroke is more or less than specified, we recommend that the system be serviced by an authorized HYUNDAI dealer.

**Stroke : 5~6 “clicks” at a force of 20 kg (44 lbs, 196 N).**

## FUEL FILTER (FOR DIESEL)

### Draining water from fuel filter

The fuel filter in the diesel engine operates the critical function of separating water from the fuels and accumulating the water in its bottom.

When enough water is accumulated inside the fuel filter, the warning light illuminates with the ignition switch in the ON position.

In this case, we recommend you to have the system checked by an authorized HYUNDAI dealer.

#### NOTICE

**When the accumulated water is not drained at a proper timing, water may permeate in the fuel filter, damaging the major vehicle components, such as the fuel system.**

### Fuel filter cartridge replacement

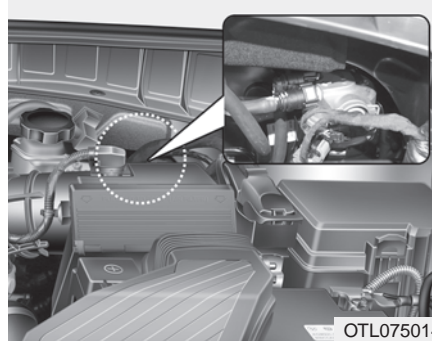

#### **i** Information

When replacing the fuel filter cartridge, we recommend that you use parts for replacement from an authorized HYUNDAI dealer.

## AIR CLEANER

### Filter replacement

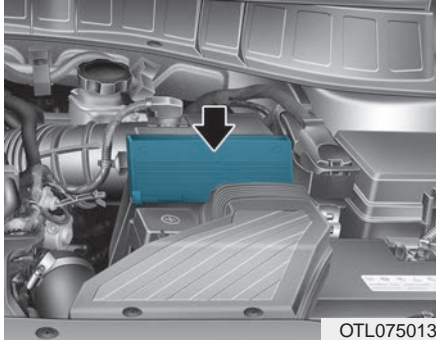

The air cleaner filter can be cleaned for inspection using compressed air. Do not attempt to wash or to rinse it, as water will damage the filter. If soiled, the air cleaner filter must be replaced.

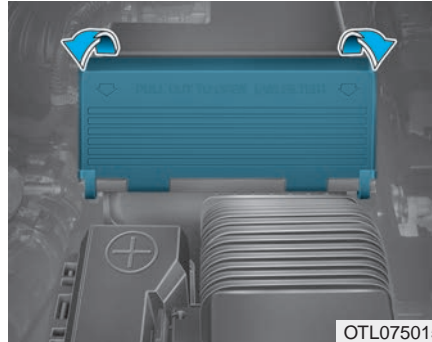

1. Pull down the air cleaner filter cover.
2. Wipe the inside of the air cleaner.

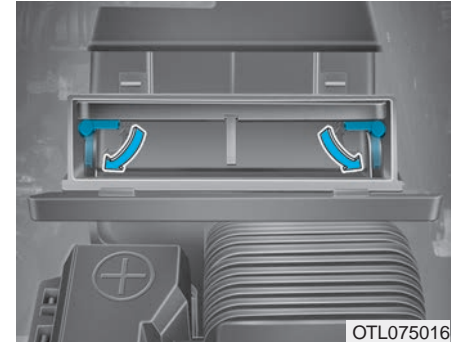

3. Pull down the lever to the UNLOCK position.

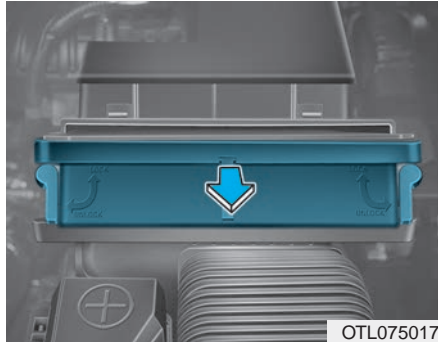

4. Replace the air cleaner filter.

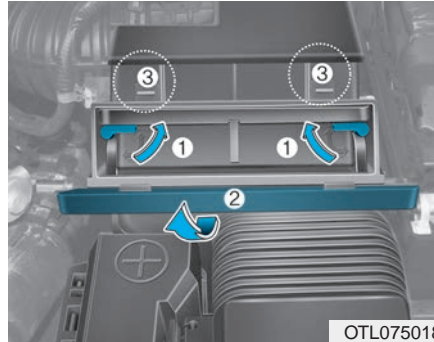

5. Pull up the lever (1) to the LOCK position.
6. Rise up the cover (2) until the hooks on the cover are securely fastened into the latches (3).
7. Check if the cover is firmly installed.

### **i** Information

If the vehicle is operated in extremely dusty or sandy areas, replace the element more often than the usual recommended intervals (refer to “Maintenance Under Severe Usage Conditions” in this chapter).

#### **NOTICE**

- Do not drive with the air cleaner filter removed. This will result in excessive engine wear.
- When removing the air cleaner filter, be careful that dust or dirt does not enter the air intake, or damage may result.
- Use HYUNDAI genuine parts, use of non-genuine parts could damage the air flow sensor.

## CLIMATE CONTROL AIR FILTER

### Filter inspection

If the vehicle is operated in the severely air-polluted cities or on dusty rough roads for a long period, it should be inspected more frequently and replaced earlier. When you, the owner, replace the climate control air filter, replace it performing the following procedure, and be careful to avoid damaging other components.

Replace the filter according to the Maintenance Schedule.

### NOTICE

**Install a new climate control air filter in the correct direction with the arrow symbol(↓) facing downwards. Otherwise, the climate control effects may decrease, possibly with a noise.**

### Filter replacement

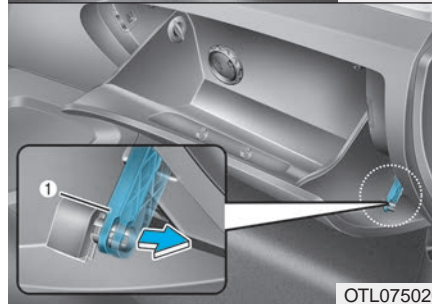
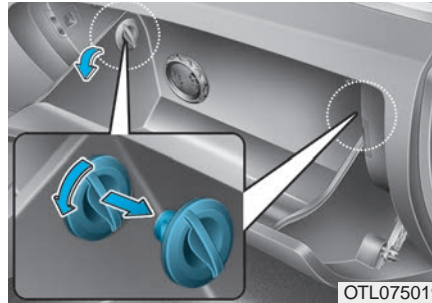

1. With the glove box open, remove the stoppers on both sides.
2. Remove the support strap (1).

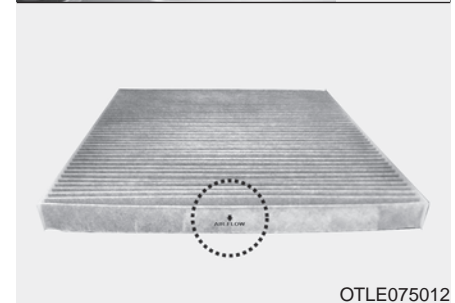
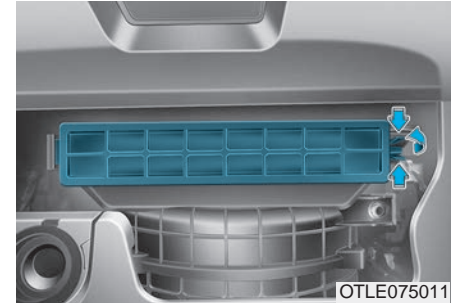

3. Remove the climate control air filter case while pressing the lock on the right side of the cover.
4. Replace the climate control air filter.
5. Reassemble in the reverse order of disassembly.

## WIPER BLADES

### Blade inspection

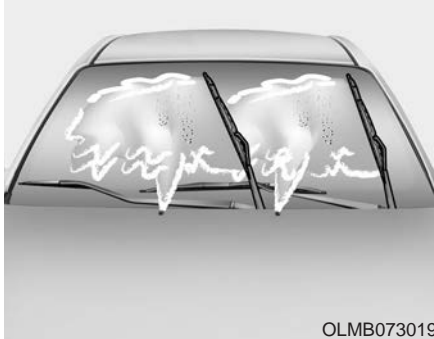

OLMB073019

#### **i** Information

Commercial hot waxes applied by automatic car washes have been known to make the windshield difficult to clean.

Contamination of either the windshield or the wiper blades with foreign matter can reduce the effectiveness of the windshield wipers.

Common sources of contamination are insects, tree sap, and hot wax treatments used by some commercial car washes. If the blades are not wiping properly, clean both the window and the blades with a good cleaner or mild detergent, and rinse thoroughly with clean water.

#### **NOTICE**

To prevent damage to the wiper blades, do not use gasoline, kerosene, paint thinner, or other solvents on or near them.

#### **i** Information

Wiper blades are consumable item and normal wear of the wipers may not be covered by your vehicle warranty.

### Blade replacement

When the wipers no longer clean adequately, the blades may be worn or cracked, and require replacement.

#### **NOTICE**

To prevent damage to the wiper arms or other components, do not attempt to move the wipers manually.

#### **NOTICE**

The use of a non-specified wiper blade could result in wiper malfunction and failure.

#### **CAUTION**

Do not allow the wiper arm to fall against the windshield, since it may chip or crack the windshield.

### Front windshield wiper blade



1. Raise the wiper arm.

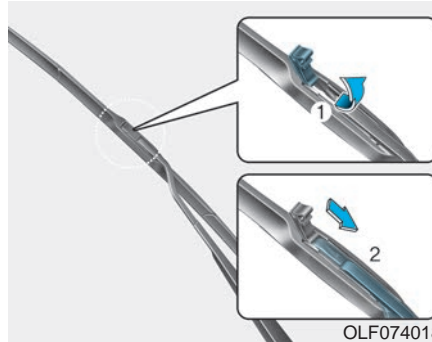

2. Lift up the wiper blade clip. Then pull down the blade assembly and remove it.

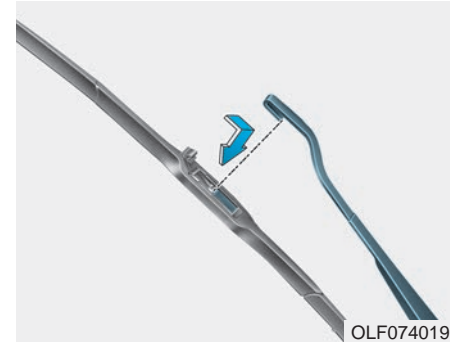

3. Install the new blade assembly in the reverse order of removal.  
4. Return the wiper arm on the windshield.

## Rear window wiper blade

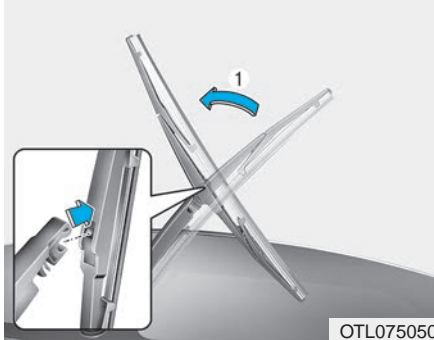

1. Raise the wiper arm and pull out the wiper blade assembly.

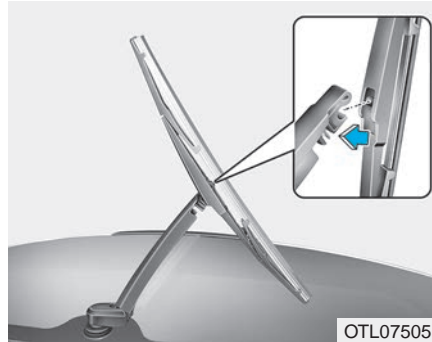

2. Install the new blade assembly by inserting the center part into the slot in the wiper arm until it clicks into place.
3. Make sure the blade assembly is installed firmly by trying to pull it slightly.

To prevent damage to the wiper arms or other components, we recommend that the wiper blade be replaced by an authorized HYUNDAI dealer.



## BATTERY

### For best battery service

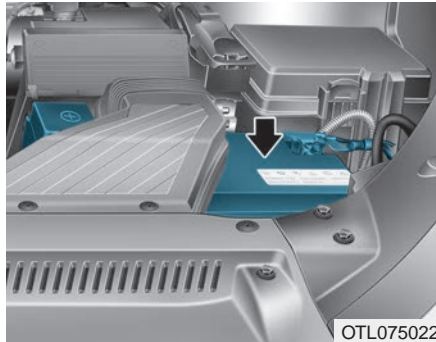

OTL075022

- Keep the battery securely mounted.
- Keep the battery top clean and dry.
- Keep the terminals and connections clean, tight, and coated with petroleum jelly or terminal grease.
- Rinse any spilled electrolyte from the battery immediately with a solution of water and baking soda.
- If the vehicle is not going to be used for an extended time, disconnect the battery cables.

**i** **Information** - For batteries marked with **UPPER** and **LOWER**

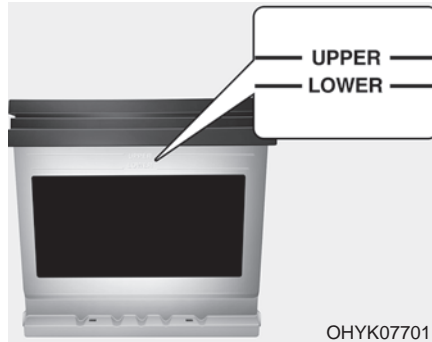

OHYK077011

If your vehicle is equipped with a battery marked with **LOWER (MIN)** and **UPPER (MAX)** on the side, you should check the electrolyte level.

The electrolyte level should be between **LOWER (MIN)** and **UPPER (MAX)**. When the electrolyte level is low, add distilled (or de-mineralized) water. (Never add sulfuric acids or other electrolyte).

Be careful not to spill distilled (or de-mineralized) water over the battery surface or other adjacent components.

(continued)

(continued)

Also, do not overfill the battery cells.

If not, it may corrode the battery or other components. Finally, securely close the cell cap. However, we recommend you to contact an authorized **HYUNDAI** dealer for better battery service.

### **WARNING**

To prevent **SERIOUS INJURY** or **DEATH** to you or bystanders, always follow these precautions when working near or handling the battery:



Always read and follow instructions carefully when handling a battery.



Wear eye protection designed to protect the eyes from acid splashes.



Keep all flames, sparks, or smoking materials away from the battery.



Hydrogen is always present in battery cells, is highly combustible, and may explode if ignited.

(Continued)

(Continued)



Keep batteries out of reach of children.



Batteries contain sulfuric acid which is highly corrosive. Do not allow acid to contact your eyes, skin or clothing.

If acid gets into your eyes, flush your eyes with clean water for at least 15 minutes and get immediate medical attention. If acid gets on your skin, thoroughly wash the area. If you feel pain or a burning sensation, get medical attention immediately.

- When lifting a plastic-cased battery, excessive pressure on the case may cause battery acid to leak. Lift with a battery carrier or with your hands on opposite corners.
- Do not attempt to jump start your vehicle if your battery is frozen.

(Continued)

(Continued)

- NEVER attempt to recharge the battery when the vehicle's battery cables are connected to the battery.
- The electrical ignition system works with high voltage. NEVER touch these components with the engine running or when the Engine Start/Stop button is in the ON position.
- Do not allow the (+) and (-) jumper cables to touch. It may cause sparks.
- The battery may rupture or explode when you jump start with a low or frozen battery.

## **i** Information



An inappropriately disposed battery can be harmful to the environment and human health. Dispose the battery according to your local law(s) or regulations.

### **NOTICE**

If you connect unauthorized electronic devices to the battery, the battery may be discharged. Never use unauthorized devices.

## Battery capacity label

■ Example



OLMB073072

The actual battery label in the vehicle may differ from the illustration.

1. CMF60L-BCI : The HYUNDAI model name of battery
2. 12V : The nominal voltage
3. 60Ah(20HR) : The nominal capacity (in Ampere hours)
4. 92RC : The nominal reserve capacity (in min.)
5. 550CCA : The cold-test current in amperes by SAE
6. 440A : The cold-test current in amperes by EN

### CAUTION

#### AGM battery (if equipped)

- **Absorbent Glass Matt (AGM) batteries are maintenance-free and we recommend that the AGM battery be serviced by an authorized HYUNDAI dealer. For charging your AGM battery, use only fully automatic battery chargers that are specially developed for AGM batteries.**
- **When replacing the AGM battery, we recommend that you use parts for replacement from an authorized HYUNDAI dealer.**
- **Do not open or remove the cap on top of the battery. This may cause leaks of internal electrolyte that could result in severe injury.**

## Battery recharging

Your vehicle has a maintenance-free, calcium-based battery.

- If the battery becomes discharged in a short time (because, for example, the headlights or interior lights were left on while the vehicle was not in use), recharge it by slow charging (trickle) for 10 hours.
- If the battery gradually discharges because of high electric load while the vehicle is being used, recharge it at 20-30A for two hours.

**⚠ WARNING**

When recharging the battery, observe the following precautions:

- Before performing maintenance or recharging the battery, turn off all accessories and stop the engine.
- Do not allow cigarettes, sparks, or flame near the battery.
- Wear eye protection when checking the battery during charging.
- The battery must be removed from the vehicle and placed in an area with good ventilation.
- Watch the battery during charging, and stop or reduce the charging rate if the battery cells begin gassing (boiling) violently or if the temperature of the electrolyte of any cell exceeds 49°C (120°F).

(Continued)

(Continued)

- The negative battery cable must be removed first and installed last when the battery is disconnected.
- Disconnect the battery charger in the following order.
  1. Turn off the battery charger main switch.
  2. Unhook the negative clamp from the negative battery terminal.
  3. Unhook the positive clamp from the positive battery terminal.

**Reset items**

Items should be reset after the battery has been discharged or the battery has been disconnected.

- Auto up/down window (See chapter 3)
- Sunroof (See chapter 3)
- Trip computer (See chapter 3)
- Climate control system (See chapter 3)

## TIRES AND WHEELS

### Tire care

For proper maintenance, safety, and maximum fuel economy, you must always maintain recommended tire inflation pressures and stay within the load limits and weight distribution recommended for your vehicle.

### Recommended cold tire inflation pressures

All tire pressures (including the spare) should be checked when the tires are cold. "Cold Tires" means the vehicle has not been driven for at least three hours or driven less than 1.6 km (1 mile).

Recommended pressures must be maintained for the best ride, top vehicle handling, and minimum tire wear.

**For recommended inflation pressure refer to "Tire and wheels" in chapter 8.**

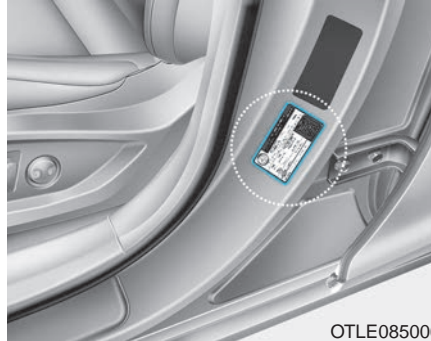

OTLE085006

All specifications (sizes and pressures) can be found on a label attached to the vehicle.

### WARNING

#### Tire underinflation

**Severe underinflation (70 kPa (10 psi) or more) can lead to severe heat build-up, causing blowouts, tread separation and other tire failures that can result in the loss of vehicle control leading to severe injury or death. This risk is much higher on hot days and when driving for long periods at high speeds.**

 **CAUTION**

- Underinflation also results in excessive wear, poor handling and reduced fuel economy. Wheel deformation also is possible. Keep your tire pressures at the proper levels. If a tire frequently needs refilling, we recommend that the tire be checked by an authorized HYUNDAI dealer.
- Overinflation produces a harsh ride, excessive wear at the center of the tire tread, and a greater possibility of damage from road hazards.

 **CAUTION**

- Warm tires normally exceed recommended cold tire pressures by 28 to 41 kPa (4 to 6 psi). Do not release air from warm tires to adjust the pressure or the tires will be underinflated.
- Be sure to reinstall the tire inflation valve caps. Without the valve cap, dirt or moisture could get into the valve core and cause air leakage. If a valve cap is missing, install a new one as soon as possible.

 **WARNING****Tire inflation**

Overinflation or underinflation can reduce tire life, adversely affect vehicle handling, and lead to sudden tire failure. This could result in loss of vehicle control and potential injury.

 **CAUTION****Tire pressure**

Always observe the following:

- Check tire pressure when the tires are cold. (After vehicle has been parked for at least three hours or hasn't been driven more than 1.6 km (1 mile) since startup.)
- Check the pressure of your spare tire each time you check the pressure of other tires.
- Never overload your vehicle. Be careful not to overload a vehicle luggage rack if your vehicle is equipped with one.
- Worn, old tires can cause accidents. If your tread is badly worn, or if your tires have been damaged, replace them.

### Checking tire inflation pressure

Check your tires once a month or more.

Also, check the tire pressure of the spare tire.

#### **How to check**

Use a good quality gage to check tire pressure. You can not tell if your tires are properly inflated simply by looking at them. Radial tires may look properly inflated even when they're underinflated.

Check the tire's inflation pressure when the tires are cold. - "Cold" means your vehicle has been sitting for at least three hours or driven no more than 1.6 km (1 mile).

Remove the valve cap from the tire valve stem. Press the tire gage firmly onto the valve to get a pressure measurement. If the cold tire inflation pressure matches the recommended pressure on the tire and loading information label, no further adjustment is necessary. If the pressure is low, add air until you reach the recommended amount.

If you overfill the tire, release air by pushing on the metal stem in the center of the tire valve. Recheck the tire pressure with the tire gage. Be sure to put the valve caps back on the valve stems. They help prevent leaks by keeping out dirt and moisture.

### WARNING

- **Inspect your tires frequently for proper inflation as well as wear and damage. Always use a tire pressure gauge.**
- **Tires with too much or too little pressure wear unevenly causing poor handling, loss of vehicle control, and sudden tire failure leading to accidents, injuries, and even death. The recommended cold tire pressure for your vehicle can be found in this manual and on the tire label located on the driver's side center pillar.**
- **Worn tires can cause accidents. Replace tires that are worn, show uneven wear, or are damaged.**
- **Remember to check the pressure of your spare tire.**  
**HYUNDAI recommends that you check the spare every time you check the pressure of the other tires on your vehicle.**

## Tire rotation

To equalize tread wear, it is recommended that the tires be rotated every 12,000 km (7,500 miles) or sooner if irregular wear develops.

During rotation, check the tires for correct balance.

When rotating tires, check for uneven wear and damage. Abnormal wear is usually caused by incorrect tire pressure, improper wheel alignment, out-of-balance wheels, severe braking or severe cornering. Look for bumps or bulges in the tread or side of tire. Replace the tire if you find either of these conditions. Replace the tire if fabric or cord is visible. After rotation, be sure to bring the front and rear tire pressures to specification and check lug nut tightness.

**Refer to “Tire and wheels” in chapter 8.**

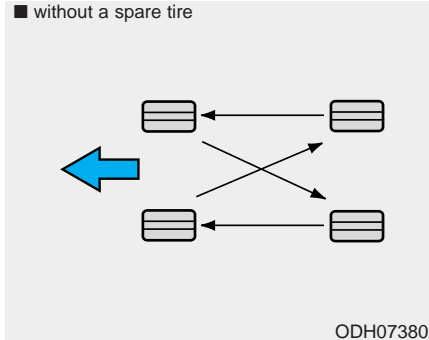

*Disc brake pads should be inspected for wear whenever tires are rotated.*

## **i** Information

The outside and inside of the unsymmetrical tire is distinguishable. When installing an unsymmetrical tire, be sure to install the side marked "outside" face the outside. If the side marked "inside" is installed on the outside, it will have a bad effect on vehicle performance.

## **⚠** WARNING

- Do not use the compact spare tire for tire rotation.
- Do not mix bias ply and radial ply tires under any circumstances. This may cause unusual handling characteristics that could result in death, severe injury, or property damage.



### Wheel alignment and tire balance

The wheels on your vehicle were aligned and balanced carefully at the factory to give you the longest tire life and best overall performance.

In most cases, you will not need to have your wheels aligned again. However, if you notice unusual tire wear or your vehicle pulling one way or the other, the alignment may need to be reset.

If you notice your vehicle vibrating when driving on a smooth road, your wheels may need to be rebalanced.

#### **NOTICE**

**Improper wheel weights can damage your vehicle's aluminum wheels. Use only approved wheel weights.**

### Tire replacement



If the tire is worn evenly, a tread wear indicator will appear as a solid band across the tread. This shows there is less than 1.6 mm (1/16 in.) of tread left on the tire. Replace the tire when this happens.

Do not wait for the band to appear across the entire tread before replacing the tire.

#### **⚠ WARNING**

**When replacing the tires, recheck and tighten the wheel nuts after driving about 1,000 km (620 miles). If the steering wheel shakes or the vehicle vibrates while driving, the tire is out of balance. Align the tire balance. If the problem is not solved, we recommend that you contact an authorized HYUNDAI dealer.**

## **⚠ WARNING**

- **Driving on worn-out tires is very hazardous and will reduce braking effectiveness, steering accuracy, and traction.**
- **Your vehicle is equipped with tires designed to provide for safe ride and handling capability. Do not use a size and type of tire and wheel that is different from the one that is originally installed on your vehicle. It can affect the safety and performance of your vehicle, which could lead to handling failure or rollover and serious injury. When replacing the tires, be sure to equip all four tires with the tire and wheel of the same size, type, tread, brand and load-carrying capacity.**

(Continued)

(Continued)

- **The use of any other tire size or type may seriously affect ride, handling, ground clearance, stopping distance, body to tire clearance, snow tire clearance, and speedometer reliability.**
- **When replacing tires (or wheels), it is recommended to replace the two front or two rear tires (or wheels) as a pair. Replacing just one tire can seriously affect your vehicle's handling.**
- **The ABS works by comparing the speed of the wheels. Tire size can affect wheel speed. When replacing tires, all 4 tires must use the same size originally supplied with the vehicle. Using tires of a different size can cause the ABS (Anti-lock Brake System) and ESC (Electronic Stability Control) (if equipped) to work irregularly.**

### ***Compact spare tire replacement (if equipped)***

A compact spare tire has a shorter tread life than a regular size tire. Replace it when you can see the tread wear indicator bars on the tire. The replacement compact spare tire should be the same size and design tire as the one provided with your new vehicle and should be mounted on the same compact spare tire wheel. The compact spare tire is not designed to be mounted on a regular size wheel, and the compact spare tire wheel is not designed for mounting a regular size tire.

### Wheel replacement

When replacing the metal wheels for any reason, make sure the new wheels are equivalent to the original factory units in diameter, rim width and offset.

#### WARNING

**A wheel that is not the correct size may adversely affect wheel and bearing life, braking and stopping abilities, handling characteristics, ground clearance, body-to-tire clearance, snow chain clearance, speedometer and odometer calibration, headlamp aim and bumper height.**

### Tire traction

Tire traction can be reduced if you drive on worn tires, tires that are improperly inflated or on slippery road surfaces. Tires should be replaced when tread wear indicators appear. To reduce the possibility of losing control, slow down whenever there is rain, snow or ice on the road.

### Tire maintenance

In addition to proper inflation, correct wheel alignment helps to decrease tire wear. If you find a tire is worn unevenly, have your dealer check the wheel alignment.

When you have new tires installed, make sure they are balanced. This will increase vehicle ride comfort and tire life. Additionally, a tire should always be rebalanced if it is removed from the wheel.

### Tire sidewall labeling

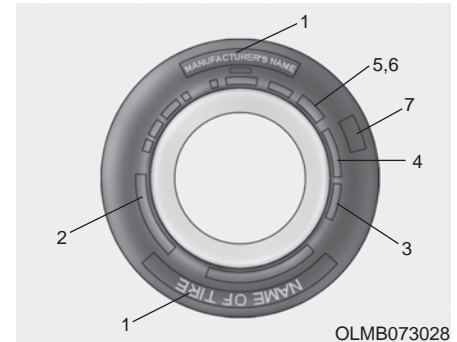

This information identifies and describes the fundamental characteristics of the tire and also provides the tire identification number (TIN) for safety standard certification. The TIN can be used to identify the tire in case of a recall.

#### **1. Manufacturer or brand name**

Manufacturer or Brand name is shown.

## 2. Tire size designation

A tire's sidewall is marked with a tire size designation. You will need this information when selecting replacement tires for your car. The following explains what the letters and numbers in the tire size designation mean.

Example tire size designation:

(These numbers are provided as an example only; your tire size designator could vary depending on your vehicle.)

### **215/70R16 100H**

215 - Tire width in millimeters.

70 - Aspect ratio. The tire's section height as a percentage of its width.

R - Tire construction code (Radial).

16 - Rim diameter in inches.

100 - Load Index, a numerical code associated with the maximum load the tire can carry.

H - Speed Rating Symbol. See the speed rating chart in this section for additional information.

## Wheel size designation

Wheels are also marked with important information that you need if you ever have to replace one. The following explains what the letters and numbers in the wheel size designation mean.

Example wheel size designation:

### **6.5JX16**

6.5 - Rim width in inches.

J - Rim contour designation.

16 - Rim diameter in inches.

### Tire speed ratings

The chart below lists many of the different speed ratings currently being used for passenger car tires. The speed rating is part of the tire size designation on the sidewall of the tire. This symbol corresponds to that tire's designed maximum safe operating speed.

Speed Rating Symbol	Maximum Speed
S	180 km/h (112 mph)
T	190 km/h (118 mph)
H	210 km/h (130 mph)
V	240 km/h (149 mph)
W	270 km/h (168 mph)
Y	300 km/h (186 mph)

### 3. Checking tire life (TIN : Tire Identification Number)

Any tires that are over 6 years old, based on the manufacturing date, tire strength and performance, decline with age naturally (even unused spare tires). Therefore, the tires (including the spare tire) should be replaced by new ones. You can find the manufacturing date on the tire sidewall (possibly on the inside of the wheel), displaying the DOT Code. The DOT Code is a series of numbers on a tire consisting of numbers and English letters. The manufacturing date is designated by the last four digits (characters) of the DOT code.

#### DOT : XXXX XXXX OOOO

The front part of the DOT means a plant code number, tire size and tread pattern and the last four numbers indicate week and year manufactured.

For example:

DOT XXXX XXXX 1619 represents that the tire was produced in the 16th week of 2019.

### WARNING

#### Tire age

**Tires degrade over time, even when they are not being used. Regardless of the remaining tread, it is recommended that tires generally be replaced after six (6) years of normal service. Heat caused by hot climates or frequent high loading conditions can accelerate the aging process. Failure to follow this Warning can result in sudden tire failure, which could lead to a loss of control and an accident involving serious injury or death.**

#### **4. Tire ply composition and material**

The number of layers or plies of rubber-coated fabric are in the tire. Tire manufacturers also must indicate the materials in the tire, which include steel, nylon, polyester, and others. The letter "R" means radial ply construction; the letter "D" means diagonal or bias ply construction; and the letter "B" means belted-bias ply construction.

#### **5. Maximum permissible inflation pressure**

This number is the greatest amount of air pressure that should be put in the tire. Do not exceed the maximum permissible inflation pressure. Refer to the Tire and Loading Information label for recommended inflation pressure.

#### **6. Maximum load rating**

This number indicates the maximum load in kilograms and pounds that can be carried by the tire. When replacing the tires on the vehicle, always use a tire that has the same load rating as the factory installed tire.

#### **7. Uniform tire quality grading**

Quality grades can be found where applicable on the tire sidewall between tread shoulder and maximum section width.

For example:

TREADWEAR 200

TRACTION AA

TEMPERATURE A

#### **Tread wear**

The tread wear grade is a comparative rating based on the wear rate of the tire when tested under controlled conditions on a specified government test course. For example, a tire graded 150 would wear one-and-a-half times (1½) as well on the government course as a tire graded 100.

The relative performance of tires depends upon the actual conditions of their use, however, and may depart significantly from the norm because of variations in driving habits, service practices and differences in road characteristics and climate.

These grades are molded on the side-walls of passenger vehicle tires. The tires available as standard or optional equipment on your vehicles may vary with respect to grade.

### Traction - AA, A, B & C

The traction grades, from highest to lowest, are AA, A, B and C. Those grades represent the tires ability to stop on wet pavement as measured under controlled conditions on specified government test surfaces of asphalt and concrete. A tire marked C may have poor traction performance.

#### WARNING

**The traction grade assigned to this tire is based on straight-ahead braking traction tests, and does not include acceleration, cornering, hydroplaning, or peak traction characteristics.**

### Temperature - A, B & C

The temperature grades are A (the highest), B and C representing the tire's resistance to the generation of heat and its ability to dissipate heat when tested under controlled conditions on a specified indoor laboratory test wheel.

Sustained high temperature can cause the material of the tire to degenerate and reduce tire life, and excessive temperature can lead to sudden tire failure. Grades B and A represent higher levels of performance on the laboratory test wheel than the minimum required by the law.

#### WARNING

##### Tire temperature

**The temperature grade for this tire is established for a tire that is properly inflated and not overloaded. Excessive speed, under-inflation, or excessive loading, either separately or in combination, can cause heat build-up and possible sudden tire failure. This can cause loss of vehicle control and serious injury or death.**

## Low aspect ratio tire (if equipped)

The low aspect ratio tires, of which aspect ratio is below 50, are equipped with for the sporty look.

Riding with high aspect ratio tires may be uncomfortable with unpleasant noises, because the low aspect ratio tires are optimized for handling and braking.

### NOTICE

The sidewall of the low aspect ratio tire is thinner than the high aspect ratio tire. Thus, the wheel and the tire may be easily damaged. Thus, follow the below instructions.

- **Cautiously drive the vehicle on a rough road or off the road. Otherwise, the tires and wheels may be damaged. After driving those areas, inspect the tires and wheels.**
- **Slowly drive the vehicle to pass over a pothole, speed bump, manhole, or curb stone. Otherwise, the tires and wheels may be damaged.**
- **Upon having an impact on the tire, we recommend you to have the tires inspected by an authorized HYUNDAI dealer.**
- **Inspect the tires every 3,000 km to prevent damage**

### NOTICE

- **It is difficult to recognize tire damage only with eyes. However, we recommend you to have the tire checked or replaced upon detecting even the slightest tire damage. The tire damage may leak air from the tire.**
- **Tire damage, caused by driving on a rough road, pothole, manhole or curb stone, or off the road, is not covered by the manufacturer's warranty.**
- **For further information about the tire, refer to the label on the tire sidewall.**



## FUSES

■ Blade type



Normal



Blown

■ Cartridge type



Normal



Blown

■ Multi fuse

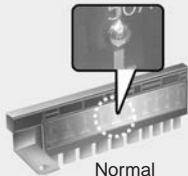

Normal

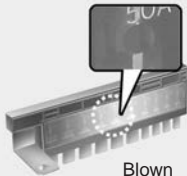

Blown

■ Battery fuse terminal



Normal



Blown

OLF074075

A vehicle's electrical system is protected from electrical overload damage by fuses.

This vehicle has 2 (or 3) fuse panels, one located in the driver's side panel bolster, the other in the engine compartment near the battery.

If any of your vehicle's lights, accessories, or controls do not work, check the appropriate circuit fuse. If a fuse has blown, the element inside the fuse will be melted.

If the electrical system does not work, first check the driver's side fuse panel. Before replacing a blown fuse, turn the engine and all switches off, and then disconnect the negative battery cable. Always replace a blown fuse with one of the same rating.

If the replacement fuse blows, this indicates an electrical problem. Avoid using the system involved and immediately consult an authorized HYUNDAI dealer.

**i** Information

**Four kinds of fuses are used : blade type for lower amperage rating, cartridge type/Multi fuse/Battery fuse terminal for higher amperage ratings.**

**⚠ WARNING****Fuse replacement**

- Never replace a fuse with anything but another fuse of the same rating.
- A higher capacity fuse could cause damage and possibly a fire.
- Never install a wire or aluminum foil instead of the proper fuse - even as a temporary repair. It may cause extensive wiring damage and a possible fire.

**NOTICE**

Do not use a screwdriver or any other metal object to remove fuses because it may cause a short circuit and damage the system.

**NOTICE**

- When replacing a blown fuse or relay with a new one, make sure the new fuse or relay fits tightly into the clips. The incomplete fastening fuse or relay may cause the vehicle wiring and electric systems damage and a possible fire.
- Do not remove fuses, relays and terminals fastened with bolts or nuts. The fuses, relays and terminals may be fastened incompletely, and it may cause a possible fire. If fuses, relays and terminals fastened with bolts or nuts are blown, we recommend that you consult an authorized HYUNDAI dealer.
- Do not input any other objects except fuses or relays into fuse/relay terminals such as a driver or wiring. It may cause contact failure and system malfunction.

### Inner panel fuse replacement



1. Turn the engine and all other switches off.
2. Open the fuse panel cover.

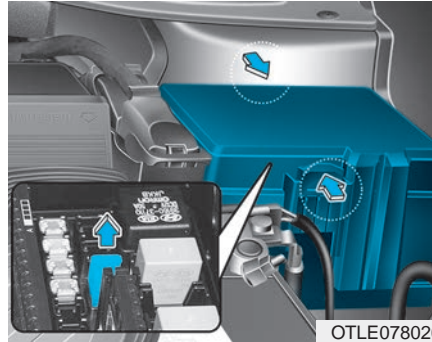

3. Pull the suspected fuse straight out. Use the removal tool provided in the engine compartment fuse panel.
4. Check the removed fuse; replace it if it is blown.
5. Push in a new fuse of the same rating, and make sure it fits tightly in the clips.

If it fits loosely, we recommend that you consult an authorized HYUNDAI dealer.

### **i** Information

If you do not have a spare, use a fuse of the same rating from a circuit you may not need for operating the vehicle, such as the cigar lighter fuse.

If the headlights or other electrical components do not work and the fuses are OK, check the fuse block in the engine compartment. If a fuse is blown, it must be replaced with the same rating.

## Fuse switch

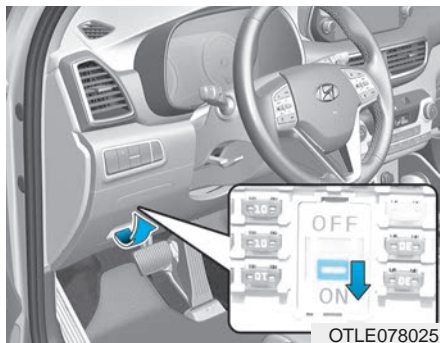

Always, place the fuse switch to the ON position.

If you move the switch to the OFF position, some items such as the audio system and digital clock must be reset and the smart key may not work properly.

## **i** Information



If the fuse switch is OFF, the above message will appear.

### **NOTICE**

- Always place the fuse switch in the ON position while driving the vehicle.
- Place the fuse switch in the OFF position when the vehicle is parked more than a month to prevent battery discharge.
- Do not move the transportation fuse switch repeatedly. The fuse switch may be damaged.

## Engine compartment panel fuse replacement

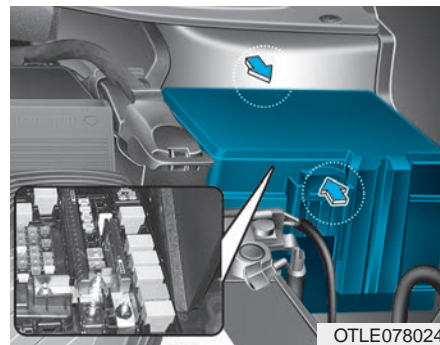

1. Turn the engine off and all other switches off.
2. Turn all the switches off.
3. Remove the fuse box cover by pressing the tab and pulling up.
4. Check the removed fuse; replace it if it is blown. To remove or insert the fuse, use the fuse puller in the engine compartment fuse panel.
5. Push in a new fuse of the same rating, and make sure it fits tightly in the clips. If it fits loosely, we recommend that you consult an authorized HYUNDAI dealer.

### NOTICE

After checking the fuse box in the engine compartment, securely install the fuse box cover. If not, electrical failures may occur from water leaking in.

### Main fuse

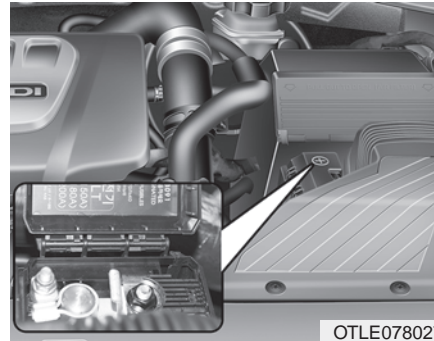

If an electrical system does not operate with no blown fuse in the engine room and inner fuse box, the main fuse inside the battery (+) cap may be blown.

The main fuse is heavily connected to many other parts. In this case, we recommend you to contact an authorized HYUNDAI dealer.

### Multi fuse

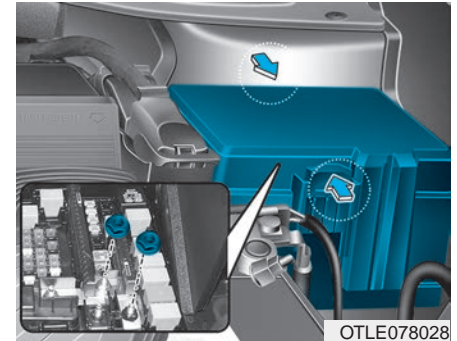

If the multi fuse is blown, it must be removed as follows:





1. Disconnect the negative battery cable.
2. Remove the nuts shown in the picture above.
3. Replace the fuse with a new one of the same rating.
4. Reinstall in the reverse order of removal.





### **i** Information

If the multi fuse is blown, we recommend that you consult an authorized HYUNDAI dealer.









## Driver's side fuse panel

Fuse Name	Symbol	Fuse Rating	Circuit Protected
A/CON 1	<sup>1</sup> A/C	7.5A	A/C Control Module, Cluster Ionizer (Auto A/C), E/R Junction Block (RLY.4, 5, 13)
WIPER RR		15A	ICM Relay Box (Rear Wiper Relay), Rear Wiper Motor
MODULE 6	<sup>6</sup> MODULE	10A	BCM, Smart Key Control Module
WASHER		15A	Multifunction Switch (Washer Switch)
MODULE 5	<sup>5</sup> MODULE	7.5A	Crash Pad Switch, Rear Parking Assist Buzzer, BCM, 4WD ECM, Forward Collision Avoidance Assist Unit, Steering Angle Sensor, Blind Spot Detection Radar LH/RH, Console Switch, Smart Parking Assist Control Module, Lane Keeping Assist Control Module
AIR BAG		15A	SRS Control Module
MODULE 1	<sup>1</sup> MODULE	10A	BCM, A/V & Navigation Head Unit, MTS E-Call Module, AUDIO, Low DC-DC Converter, Smart Key Control Module, AMP, Power Outside Mirror Switch, PCB Block (Power Outlet Relay), Surround View Monitor, Wireless Charger Unit, Rear USB Port
START		10A	ICM Relay Box (Burglar Alarm Relay), Transaxle Range Switch
MODULE 7	<sup>7</sup> MODULE	7.5A	Front Air Ventilation Seat Module, Front Seat Warmer Module, Rear Seat Warmer, Surround View Monitor
HEATED STEERING		15A	BCM
MODULE 8	<sup>8</sup> MODULE	7.5A	Driver/Passenger Power Outside Mirror, Driver/Passenger Smart Key Outside Handle, Forward Collision Avoidance Assist Unit, Data Link Connector









Fuse Name	Symbol	Fuse Rating	Circuit Protected
MODULE 4	<sup>4</sup> <b>MODULE</b>	7.5A	A/C Control Module, ATM Shift Lever Ill., Head Lamp LH/RH, A/V & Navigation Head Unit, Electro Chromic Mirror, AMP, Clutch Sensor, Crash Pad Switch, Multipurpose Check Connector, Auto Head Lamp Leveling Device Module, MTS E-Call Module, Front Air Ventilation Seat Module, Low DC-DC Converter, Front Seat Warmer Module, Rear Seat Warmer, Driver Curtain Air Bag
A/BAG IND	IND 	7.5A	Instrument Cluster, Center Facia Switch
MODULE 3	<sup>3</sup> <b>MODULE</b>	10A	BCM, ATM Shift Lever, Stop Lamp Switch
SMART KEY1	<sup>1</sup> SMART KEY	15A	Smart Key Control Module
4WD		20A	4WD ECM
TAILGATE OPEN		10A	Tail Gate Relay
S/HEATER RR	RR 	15A	Rear Seat Warmer
MDPS	 1	7.5A	MDPS Unit
SMART KEY 3	<sup>3</sup> <b>SMART KEY</b>	7.5A	Smart Key Control Module, Immobilizer Module
CLUSTER	<b>CLUSTER</b>	7.5A	Instrument Cluster
SMART KEY 2	<sup>2</sup> SMART KEY	10A	Smart Key Control Module, Start/Stop Button Switch, Immobilizer Module
MULTI MEDIA	<b>MULTI MEDIA</b>	15A	AUDIO, A/V & Navigation Head Unit, Low DC-DC Converter



## Driver's side fuse panel

Fuse Name	Symbol	Fuse Rating	Circuit Protected
INTERIOR LAMP		10A	Ignition Key Ill. & Door Warning Switch, Luggage Lamp, Glove Box Lamp, Overhead Console Lamp, Room Lamp, Front Vanity Lamp LH/RH, Rear Personal Lamp LH/RH, Wireless Charger Unit
DOOR LOCK		20A	Door Lock Relay, Door Unlock Relay, ICM Relay Box (Dead Lock Relay)
SUNROOF2	<sup>2</sup> 	20A	Panorama Sunroof
POWER OUTLET	<b>POWER OUTLET</b>	20A	Front Power Outlet & Cigarette Lighter, Front Power Outlet #2
BRAKE SWITCH	<b>BRAKE SWITCH</b>	7.5A	Smart Key Control Module, Stop Lamp Switch
MEMORY 2	<sup>2</sup> <b>MEMORY</b>	10A	BCM, Rain Sensor, Console Switch, Security IND. A/C Control Module, Instrument Cluster, ICM Relay Box (Outside Mirror Folding/Unfolding Relay)
MEMORY 1	<sup>1</sup> <b>MEMORY</b>	10A	MTS E-Call Module
P/SEAT (PASS)	<sup>PASS</sup> 	30A	Passenger Seat Manual Switch
S/HEATER FRT	<sup>FRT</sup> 	20A	Front Air Ventilation Seat Module, Front Seat Warmer Module
MODULE 2	<sup>2</sup> <b>MODULE</b>	20A	PCB Block (Fuse - F44, F45, F49, F50, F52, F53)
SUNROOF1	<sup>1</sup> 	20A	Panorama Sunroof
RR FOG	<sup>RR</sup> 	10A	ICM Relay Box (Rear Fog Lamp Relay)

## Driver's side fuse panel

Fuse Name	Symbol	Fuse Rating	Circuit Protected
A/CON 2	<sup>2</sup> A/C	7.5A	A/C Control Module
HEATED MIRROR		10A	Driver/Passenger Power Outside Mirror, A/C Control Module, ECM/PCM
P/SEAT (DRV)	DRV 	30A	Driver Seat Manual Switch
SAFETY P/WINDOW DRV	SAFETY 	25A	Driver Safety Power Window Module
P/WINDOW RH	RH  	25A	Power Window Main Switch, Passenger Power Window Switch
SAFETY P/WINDOW PASS	SAFETY 	25A	Passenger Safety Power Window Module
P/ WINDOW LH	LH  	25A	Power Window Main Switch, Passenger Power Window Switch

## Engine compartment fuse panel









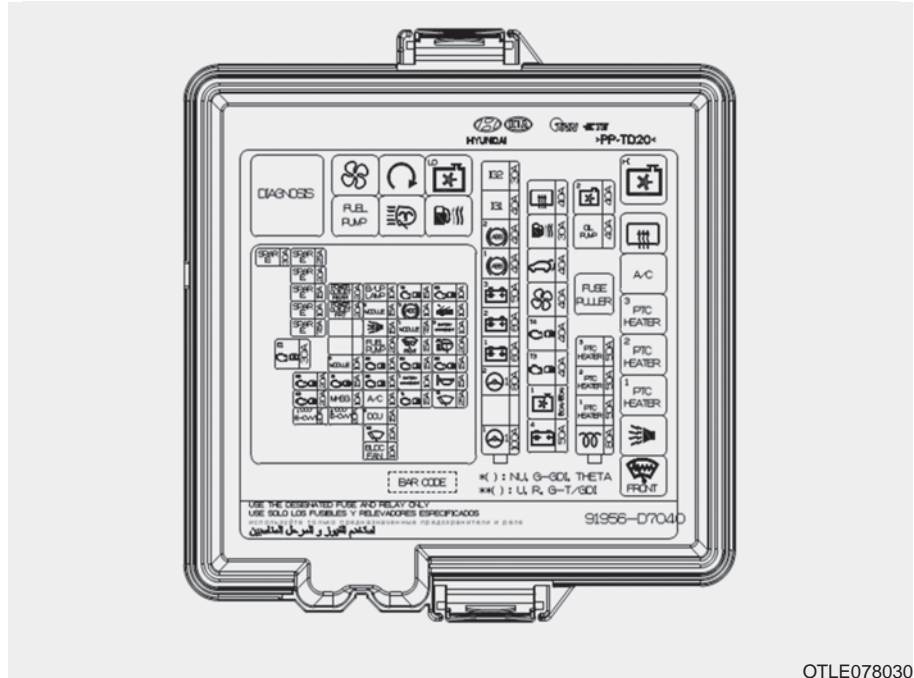

Inside the fuse/relay box covers, you can find the fuse/relay label describing fuse/relay name and capacity.

### **i** Information







Not all fuse panel descriptions in this manual may be applicable to your vehicle. It is accurate at the time of printing. When you inspect the fuse box on your vehicle, refer to the fuse box label.











## Engine compartment main fuse panel (Gasoline Engine)

	Fuse Name	Symbol	Fuse rating	Circuit Protected
MULTI FUZE	POWER STEERING1	 1	100A	MDPS Unit
	POWER STEERING2	 1	80A	MDPS Unit
	B+ 1	 1	60A	Smart Junction Block (IPS1, IPS2, IPS3, IPS4, Fuse - F50)
	B+ 2	 2	60A	Smart Junction Block (IPS5, IPS6, IPS7, IPS8, IPS9, Fuse - F19/F28/F35/F42)
	B+ 3	 3	50A	Smart Junction Block (Fuse - F23/F32/F39/F41/F46/F48, Power Window Relay)
	ABS 1	 1	40A	ESP Control Module, ABS Control Module
	ABS 2	 2	40A	ESP Control Module, ABS Control Module
	IG1	<b>IG1</b>	40A	W/O Smart Key : Ignition Switch, With Smart Key : PCB Block (PDM (IG1) Relay, PDM (ACC) Relay)
	IG2	<b>IG2</b>	30A	W/O Smart Key : Ignition Switch, With Smart Key : PCB Block (PDM (IG2) Relay)
FUZE	B+ 4	 4	50A	Smart Junction Block (Fuse - F14/F21/F22/F31/F38/F45, Leak Current Autocut Device)
	COOLING FAN1	 1	(50A) [60A]	(G4NA/G4FD/G4KJ) : E/R Junction Block (RLY. 1, RLY. 9) (G4FJ) : E/R Junction Block (RLY. 1)









Engine compartment main fuse panel (Gasoline Engine)

	Fuse Name	Symbol	Fuse rating	Circuit Protected
FUSE	TCU 3		40A	TCM
	TCU 4		40A	TCM
	BLOWER		40A	E/R Junction Block (RLY. 13)
	POWER TAILGATE		40A	Power Tail Gate Module
	REAR HEATED		40A	E/R Junction Block (RLY. 2)
	COOLING FAN2		40A	G4FJ : E/R Junction Block (RLY. 9)



## Engine compartment main fuse panel (Diesel Engine)

	Fuse Name	Symbol	Fuse rating	Circuit Protected
MULTI FUSE	POWER STEERING1	<sup>1</sup> 	100A	MDPS Unit
	POWER STEERING2	<sup>2</sup> 	80A	MDPS Unit
	B+ 1	<sup>1</sup> 	60A	Smart Junction Block (IPS1, IPS2, IPS3, IPS4, Fuse - F50)
	B+ 2	<sup>2</sup> 	60A	Smart Junction Block (IPS5, IPS6, IPS7, IPS8, IPS9, Fuse - F19/F28/F35/F42)
	B+ 3	<sup>3</sup> 	50A	Smart Junction Block (Fuse - F23/F32/F39/F41/F46/F48, Power Window Relay)
	ABS 1	<sup>1</sup> 	40A	ESP Control Module, ABS Control Module
	ABS 2	<sup>2</sup> 	40A	ESP Control Module, ABS Control Module
	IG1	<b>IG1</b>	40A	W/O Smart Key : Ignition Switch, With Smart Key : PCB Block (PDM (IG1) Relay, PDM (ACC) Relay)
	IG2	<b>IG2</b>	30A	W/O Smart Key : Ignition Switch, With Smart Key : PCB Block (PDM (IG2) Relay)
	GLOW PLUG		80A	Glow Relay Unit
	PTC 1 HEATER	<sup>1</sup> <b>PTC HEATER</b>	50A	E/R Junction Block (RLY. 6)
	PTC 2 HEATER	<sup>2</sup> <b>PTC HEATER</b>	50A	E/R Junction Block (RLY. 5)
	PTC 3 HEATER	<sup>3</sup> <b>PTC HEATER</b>	50A	E/R Junction Block (RLY. 4)

**Engine compartment main fuse panel (Diesel Engine)**



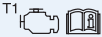

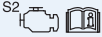

	Fuse Name	Symbol	Fuse rating	Circuit Protected
FUSE	B+ 4	<sup>4</sup> 	50A	Smart Junction Block (Fuse - F14/F21/F22/F31/F38/F45, Leak Current Autocut Device)
	COOLING FAN1	<sup>1</sup> 	60A	E/R Junction Block (RLY. 1)
	TCU 3	<sup>T3</sup> 	40A	TCM
	TCU 4	<sup>T4</sup> 	40A	TCM
	BLOWER		40A	E/R Junction Block (RLY. 13)
	POWER TAILGATE		40A	Power Tail Gate Module
	FUEL HEATER		30A	E/R Junction Block (RLY. 10)
	REAR HEATED		40A	E/R Junction Block (RLY. 2)
	COOLING FAN2	<sup>2</sup> 	40A	E/R Junction Block (RLY. 9)

### Engine compartment main fuse panel (PCB Block)

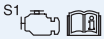

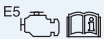

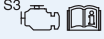
	Fuse Name	Symbol	Fuse rating	Circuit Protected
FUSE	DCU 3	<sup>3</sup> DCU	15A	Dosing Control Unit
	DCU2/ E-CVVT2	<sup>2</sup> DCU/ E-CVVT	20A	DCU2 : Dosing Control Unit E-CVVT2 : PCM
	DCU1/ E-CVVT1	<sup>1</sup> DCU/ E-CVVT	20A	DCU1 : Dosing Control Unit E-CVVT1 : PCM
	WIPER FRT1	<sup>w1</sup> 	25A	Front Wiper Motor
	TCU 1	<sup>T1</sup> 	15A	G4NA : PCM G4FJ/D4HA : TCM
	A/C COMP	A/C	10A	E/R Junction Block (RLY. 3)
	ECU 3	<sup>E3</sup> 	20A	G4NA/G4FD : PCM/ECM, G4FJ: ECM/TCM, G4KJ : PCM
	HORN		15A	Horn Relay
	BATTERY MANAGEMENT	<b>BATTERY MANAGEMENT</b>	10A	Battery Sensor
	SENSOR 2	<sup>S2</sup> 	10A	G4NA : Oil Control Valve #1/#2, Camshaft Position Sensor #1/#2, Purge Control Solenoid Valve, E/R Junction Block (RLY.3), Variable Intake Solenoid Valve G4FD/G4FJ : Oil Control Valve #1/#2, Oil Level Sensor (G4FD), Purge Control Solenoid Valve, E/R Junction Block (RLY.3) D4HA/D4FE : Crankshaft Position Sensor (D4HA), EGR Cooling Bypass Solenoid Valve (D4HA), Stop Lamp Switch, E/R Junction Block (RLY. 3/6/14) G4KJ : Oil Control Valve, Purge Control Solenoid Valve, Variable Intake Solenoid Valve, E/R Junction Block (RLY.3)





Engine compartment main fuse panel (PCB Block)

	Fuse Name	Symbol	Fuse rating	Circuit Protected
FUSE	SENSOR 1	S1 	15A	G4NA/G4KJ : Oxygen Sensor (Up/Down) G4FD : PCM/ECM, Oxygen Sensor (Up/Down) G4FJ : ECM, Oxygen Sensor (Up/Down) D4HA/D4FE : Electronic VGT Actuator (D4HA), Lambda Sensor #1/#2, PM Sensor, Mass Air Flow Sensor (D4FE), Fuel Pressure Regulating Valve (D4HA), Oil Pump Solenoid Valve (D4FE), Stop Lamp Switch (D4FE)
	ECU 2	E2 	20A	G4NA/G4FD : Ignition Coil #1/#2/#3/#4, Condenser, G4FJ : Ignition Coil #1/#2/#3/#4, D4HA/D4FE : ECM
	ECU 5	E5 	15A	G4FD : PCM/ECM, G4FJ : ECM
	ECU 4	E4 	15A	G4NA/G4FD : PCM/ECM, G4FJ/D4HA/D4FE : ECM, G4KJ : PCM
	SENSOR 3	S3 	10A	G4NA/G4FD/G4KJ : Injector #1/#2/#3/#4 (G4NA), E/R Junction Block (RLY. 1, RLY.9) G4FJ : RCV Control Solenoid Valve, Brake Booster Vacuum Pressure Switch, E/R Junction Block (RLY. 1, RLY.9) D4HA/D4FE : Mass Air Flow Sensor (D4HA), Oil Pump Solenoid Valve (D4HA), E/R Junction Block (RLY. 1, RLY.9), Electronic VGT Actuator (D4FE)
	H/LP WASHER		20A	E/R Junction Block (RLY. 12)
	DEICER		15A	E/R Junction Block (RLY. 8)

## Engine compartment main fuse panel (PCB Block)

	Fuse Name	Symbol	Fuse rating	Circuit Protected
FUSE	FUEL PUMP	<b>FUEL PUMP</b>	20A	E/R Junction Block (RLY.14)
	MODULE 1	<sup>1</sup> <b>MODULE</b>	7.5A	D4HA/D4FE : Glow Relay Unit, Fuel Filter Warning Sensor, E/R Junction Block (RLY. 10)
	B/ALARM HORN		10A	E/R Junction Block (RLY. 7)
	ACTIVE HOOD		10A	G4FD/G4FJ/D4HA/D4FE : Active Hood Lift Control Module
	ABS 3	<sup>3</sup> 	10A	ABS Control Module, ESP Control Module
	MODULE 2	<sup>2</sup> <b>MODULE</b>	15A	G4FJ : Vacuum Pump
	POWER OUTLET FRT	<b>POWER OUTLET FRT</b>	20A	Front Power Outlet & Cigarette Light
	ECU 6	<sup>E6</sup> 	10A	G4NA/G4FD : ECM/PCM G4FJ : ECM D4HA/D4FE : ECM, Oil Level Sensor G4KJ : PCM

Engine compartment main fuse panel (PCB Block)

	Fuse Name	Symbol	Fuse rating	Circuit Protected
FUSE	TCU 2	<sup>T2</sup> 	15A	[A/T] Transaxle Range Switch,TCM, ATM Shift Lever [M/T] Back-Up Lamp Switch
	B/UP LAMP	<b>B/UP LAMP</b>	10A	Transaxle Range Switch, Electro Chromic Mirror, Rear Combination Lamp (IN) LH/RH, TCM, Back-Up Lamp Switch, MTS E-Call Module, Smart Junction Block (IPS Control Module)
	POWER OUTLET REAR	<b>POWER OUTLET REAR</b>	20A	Rear Power Outlet
	WIPER FRT2	<sup>W2</sup> 	10A	BCM, G4NA/G4KJ : PCM/ECM
	MODULE 3	<sup>3</sup> <b>MODULE</b>	10A	E/R Junction Block (RLY. 14)
	ECU 1	<sup>E1</sup> 	30A	Engine Control Relay

## LIGHT BULBS

Consult an authorized HYUNDAI dealer to replace most vehicle light bulbs. It is difficult to replace vehicle light bulbs because other parts of the vehicle must be removed before you can get to the bulb. This is especially true for removing the headlamp assembly to get to the bulb(s).

Removing/installing the headlamp assembly can result in damage to the vehicle.

### WARNING

Prior to working on the light, firmly apply the parking brake, ensure that the ignition switch is in the LOCK/OFF position and turn off the lights to avoid sudden movement of the vehicle and burning your fingers or receiving an electric shock.

### NOTICE

**Be sure to replace the burned-out bulb with one of the same wattage rating. Otherwise, it may cause damage to the fuse or electric wiring system.**

### Information

After heavy driving, rain or washing, headlamp and tail lamp lenses could appear frosty. This condition is caused by the temperature difference between the lamp inside and outside. This is similar to the condensation on your windows inside your vehicle during the rain and doesn't indicate a problem with your vehicle. If the water leaks into the lamp bulb circuitry, we recommend that the system be checked by an authorized HYUNDAI dealer.

### Information - Desiccant (if equipped)

This vehicle is equipped with desiccant to reduce fogging inside the headlamp due to moisture.

The desiccant is consumable and its performance may change based on the used period or environment.

If fogging inside the headlamp due to moisture continues for a long time, we recommend that you consult an authorized HYUNDAI dealer.

### Information - Traffic Change (for Europe)

The low beam light distribution is asymmetric. If you go abroad to a country with opposite traffic direction, this asymmetric part will dazzle oncoming car driver. To prevent dazzle, ECE regulation demand several technical solutions (ex. automatic change system, adhesive sheet, down aiming). These headlamps are designed not to dazzle opposite drivers. So, you need not change your headlamps in a country with opposite traffic direction.

## Headlamp, Low Beam Assist - Static, Position lamp, Turn signal lamp and Fog lamp light bulb replacement

### Type A

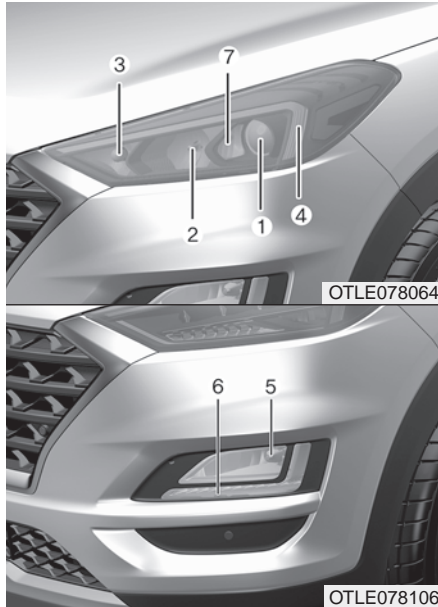

- (1) Headlamp (Low)
- (2) Headlamp (High)
- (3) Turn signal lamp
- (4) Position lamp

### Type B

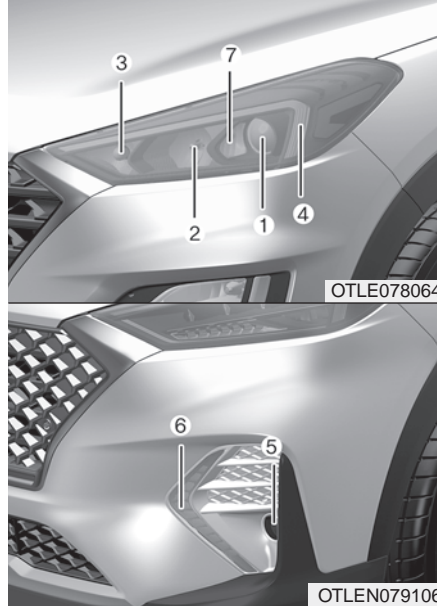

- (5) Fog lamp
- (6) Daytime running lamp
- (7) Low Beam Assist – Static (if equipped)

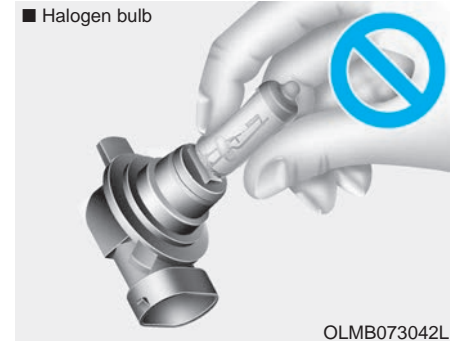

OLMB073042L

### Headlamp and Low Beam Assist – Static

#### WARNING

- Handle halogen bulbs with care. Halogen bulbs contain pressurized gas that will produce flying pieces of glass that could cause injuries if broken.
- Wear eye protection when changing a bulb. Allow the bulb to cool down before handling it.

- Always handle them carefully, and avoid scratches and abrasions. If the bulbs are lit, avoid contact with liquids.
- Never touch the glass with bare hands. Residual oil may cause the bulb to overheat and burst when lit.
- A bulb should be operated only when installed in a headlamp.
- If a bulb becomes damaged or cracked, replace it immediately and carefully dispose of it.

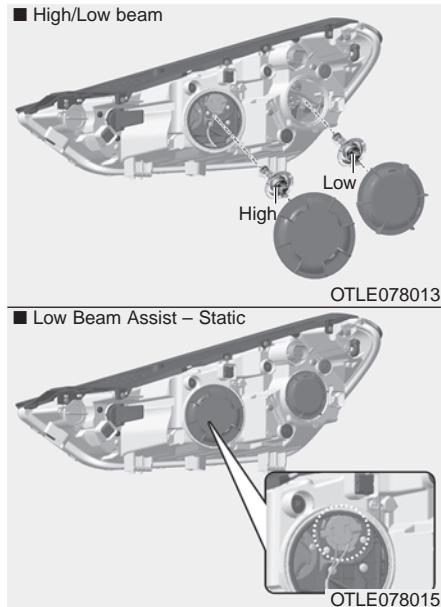

1. Open the hood.
2. Disconnect the negative battery cable.
3. Remove the bulb cover by turning it counterclockwise.
4. Disconnect the bulb socket-connector.

5. Unsnap the bulb retaining wire by pressing the end and pushing it upward.
6. Remove the bulb from the headlamp assembly.
7. Install a new bulb and snap the bulb retaining wire into position by aligning the wire with the groove on the bulb.
8. Connect the bulb socket-connector.
9. Install the bulb cover by turning it clockwise.

### **i** Information

The headlamp aiming should be adjusted after an accident or after the headlamp assembly is reinstalled at an authorized HYUNDAI dealer.

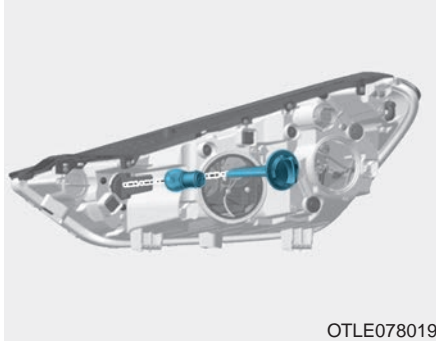

### Turn signal lamp

1. Open the hood.
2. Disconnect the negative battery cable.
3. Remove the socket from the assembly by turning the socket counterclockwise until the tabs on the socket align with the slots on the assembly.
4. Remove the bulb from the socket by pressing it in and rotating it counterclockwise until the tabs on the bulb align with the slots in the socket. Pull the bulb out of the socket.

5. Insert a new bulb by inserting it into the socket and rotating it until it locks into place.
6. Install the socket in the assembly by aligning the tabs on the socket with the slots in the assembly.
7. Push the socket into the assembly and turn the socket clockwise.

### Position lamp/Daytime running lamp

If the LED lamp does not operate, we recommend you to have the vehicle checked by an authorized HYUNDAI dealer.

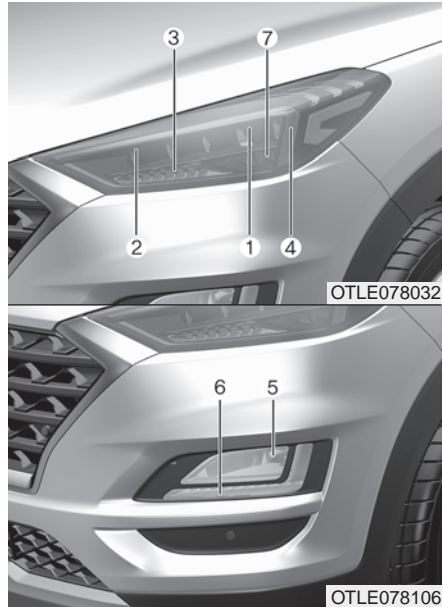
**Type C**

- (1) Headlamp (Low)
- (2) Headlamp (High)
- (3) Turn signal lamp
- (4) Position lamp

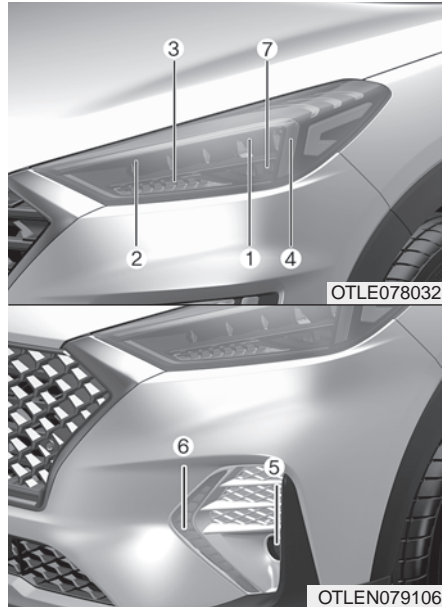
**Type D**

- (5) Fog lamp
- (6) Daytime running lamp
- (7) Low Beam Assist – Static

**Lamps**

If the LED lamp does not operate, we recommend that you have the vehicle checked by an authorized HYUNDAI dealer.



### Front fog lamp (if equipped)

■ Type A, C

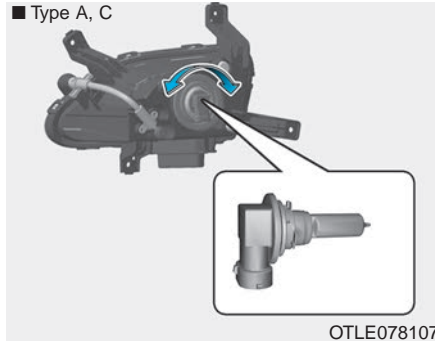

1. Loosen the pin-type retainers of the under cover and then remove the undercover.
2. Reach your hand into the back of the front bumper.
3. Disconnect the power connector from the socket.

4. Remove the bulb-socket from the housing by turning the socket counterclockwise until the tabs on the socket align with the slots of the housing.
5. Install a new bulb-socket into the housing by aligning the tabs on the socket with the slots in the housing. Push the socket into the housing and turn the socket clockwise.

■ Type B, D

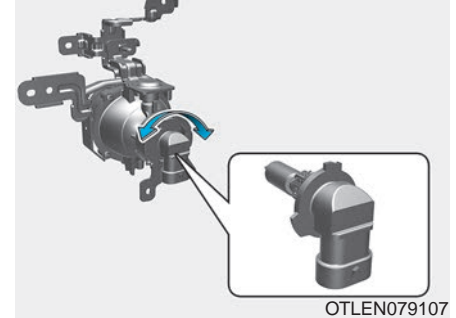

1. Loosen the pin-type retainers of the under cover and then remove the undercover.
2. Reach your hand into the back of the front bumper.
3. Disconnect the power connector from the socket.
4. Remove the bulb-socket from the housing by turning the socket counterclockwise until the tabs on the socket align with the slots of the housing.
5. Install a new bulb-socket into the housing by aligning the tabs on the socket with the slots in the housing. Push the socket into the housing and turn the socket clockwise.

## Side repeater lamp replacement

### Type A

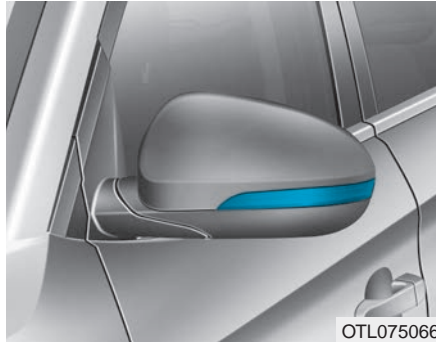

If the LED lamp does not operate, we recommend you to have the vehicle checked by an authorized HYUNDAI dealer.

### Type B

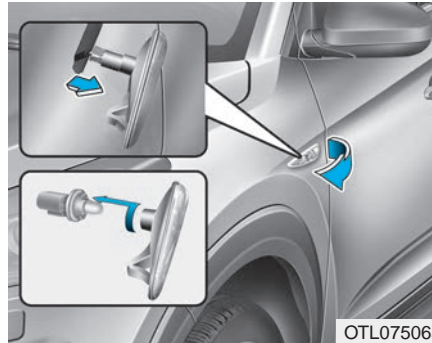

1. Remove the lamp assembly from the vehicle by prying the lens and pulling the assembly out.
2. Disconnect the bulb electrical connector.
3. Separate the socket and the lens parts by turning the socket counterclockwise until the tabs on the socket align with the slots on the lens part.
4. Remove the bulb by pulling it straight out.
5. Insert a new bulb in the socket.

6. Reassemble the socket and the lens part.
7. Connect the bulb electrical connector.
8. Reinstall the lamp assembly to the body of the vehicle.

## Headlamp and front fog lamp aiming (for Europe)

### Headlamp aiming

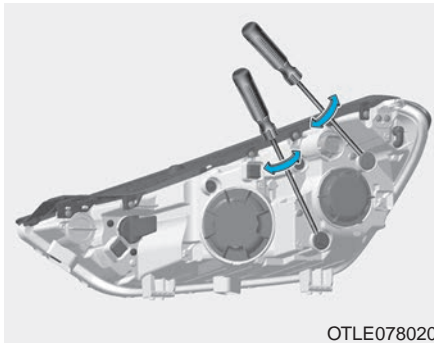

1. Inflate the tires to the specified pressure and remove any loads from the vehicle except the driver, spare tire, and tools.
2. The vehicle should be placed on a flat floor.
3. Draw vertical lines (Vertical lines passing through respective head lamp centers) and a horizontal line (Horizontal line passing through center of head lamps) on the screen.

4. With the headlamp and battery in normal condition, aim the headlamps so the brightest portion falls on the horizontal and vertical lines.

5. To aim the low beam left or right, turn the driver clockwise or counterclockwise. To aim the low beam up or down, turn the driver clockwise or counterclockwise.

To aim the high beam up or down, turn the driver clockwise or counterclockwise.

### Front fog lamp aiming

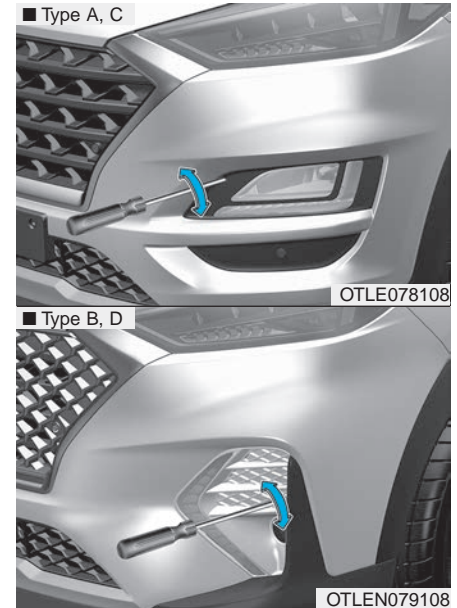

The front fog lamp can be aimed in the same manner as the headlamps. With the front fog lamps and battery in normal condition, aim the front fog lamps. To aim the front fog lamp up or down, turn the driver clockwise or counterclockwise.

## Aiming point

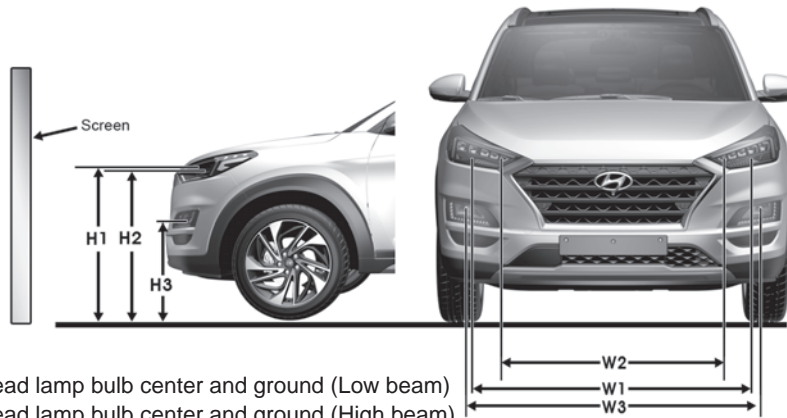

- H1 : Height between the head lamp bulb center and ground (Low beam)  
 H2 : Height between the head lamp bulb center and ground (High beam)  
 H3 : Height between the fog lamp bulb center and ground  
 W1 : Distance between the two head lamp bulbs centers (Low beam)  
 W2 : Distance between the two head lamp bulbs centers (High beam)  
 W3 : Distance between the two fog lamp bulbs centers

OTLE078022

Unit: mm (in)

Vehicle condition	Lamp type	H1	H2	H3			W1	W2	W3		
				FOG	FOG+DRL	N Line			FOG	FOG+DRL	N Line
Without driver	Halogen	881 (34.68)	852 (33.54)	576 (22.68)	593 (23.35)	454 (17.87)	1492 (58.74)	1274 (50.16)	1460 (57.48)	1474 (58.03)	1512 (59.53)
	LED	893 (35.16)	859 (33.82)				1460 (57.48)	1188 (46.77)			
With driver	Halogen	874 (34.41)	845 (33.27)	569 (22.4)	586 (23.07)	447 (17.60)	1492 (58.74)	1274 (50.16)	1460 (57.48)	1474 (58.03)	1512 (59.53)
	LED	886 (34.88)	852 (33.54)				1460 (57.48)	1188 (46.77)			

## Headlamp low beam (LHD side)

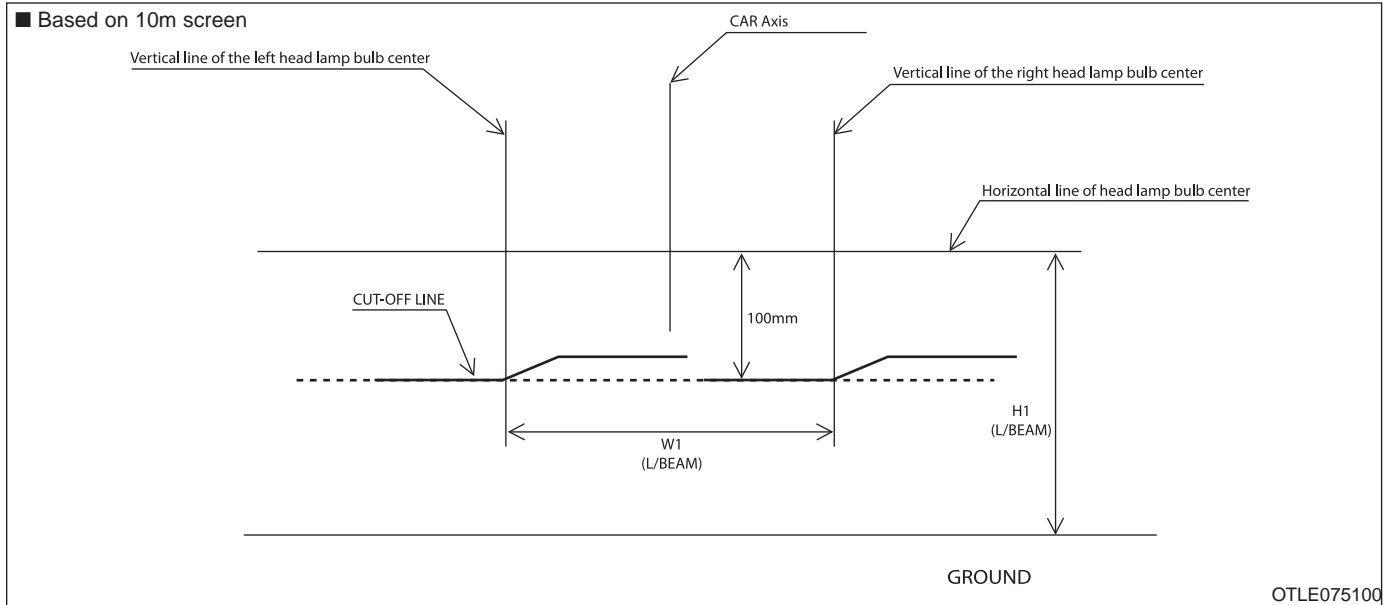

1. Turn the low beam on without driver aboard.
2. The cut-off line should be projected in the cut-off line shown in the picture.
3. When aiming the low beam, vertical aiming should be adjusted after adjusting the horizontal aiming.
4. If headlamp leveling device is equipped, adjust the head lamp leveling device switch with 0 positions.

## Headlamp low beam (RHD side)

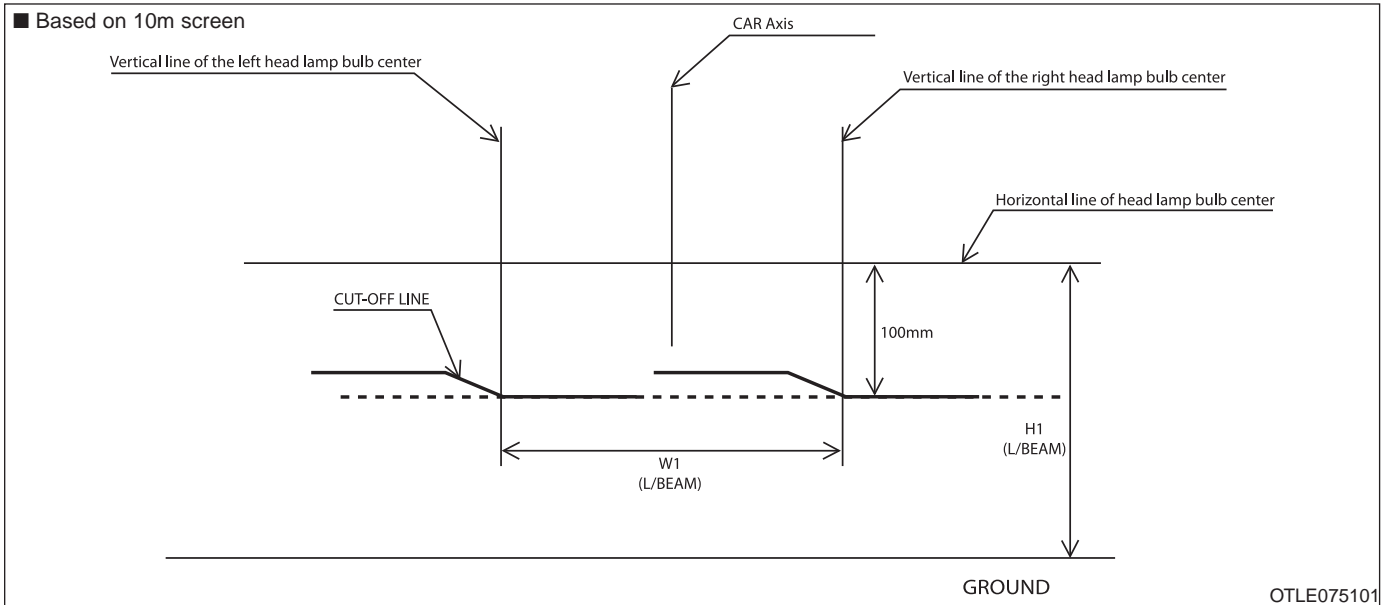

1. Turn the low beam on without driver aboard.
2. The cut-off line should be projected in the cut-off line shown in the picture.
3. When aiming the low beam, vertical aiming should be adjusted after adjusting the horizontal aiming.
4. If headlamp leveling device is equipped, adjust the head lamp leveling device switch with 0 positions.

## Front fog lamp

■ Based on 10m screen

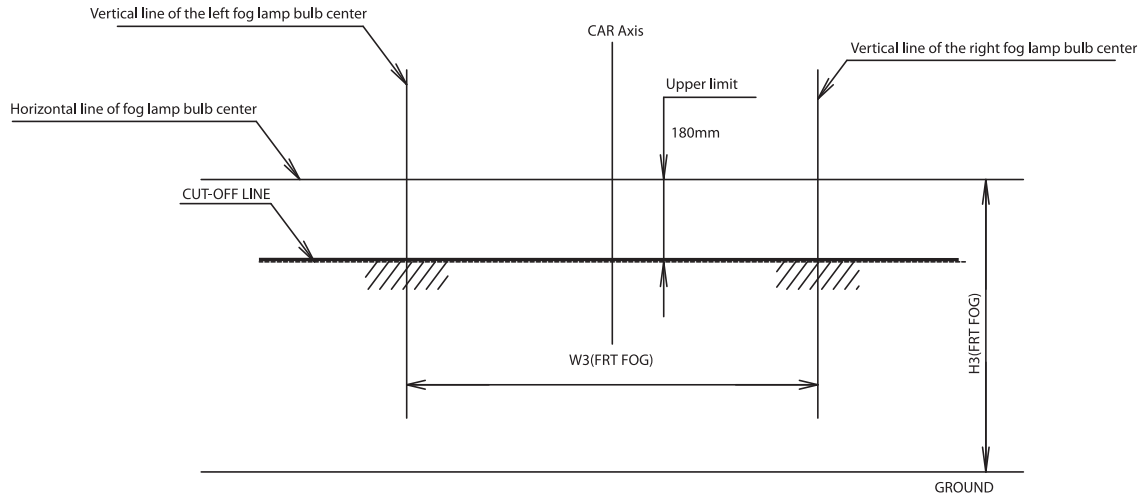

OTLE075102

1. Turn the front fog lamp on without the driver aboard.
2. The cut-off line should be projected in the allowable range (shaded region).

## Rear combination light bulb replacement

### Type A



- (1) Tail/Stop lamp
- (2) Turn signal lamp
- (3) Tail lamp
- (4) Rear fog lamp
- (5) Backup lamp

### Type B



- (1) Tail/Stop lamp, Tail lamp
- (2) Turn signal lamp
- (3) Tail lamp
- (4) Rear fog lamp
- (5) Backup lamp

## Outside lamp

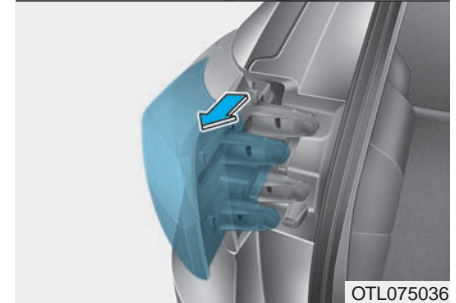
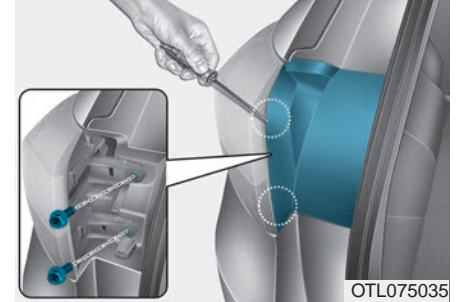

### Stop/tail Lamp and Turn signal lamp

1. Turn off the engine.
2. Open the tailgate.



- Loosen the lamp assembly retaining screws with a cross-tip screwdriver.
- Remove the rear combination lamp assembly from the body of the vehicle.

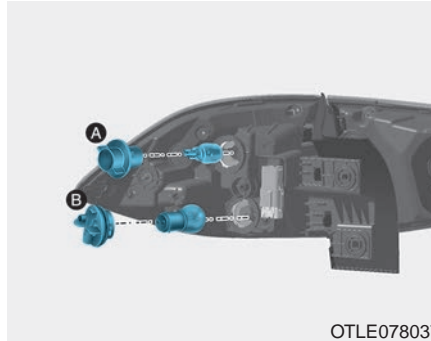

[A] : Stop/tail lamp , [B] : Turn signal lamp

- Remove the socket from the assembly by turning the socket counterclockwise until the tabs on the socket align with the slots on the assembly.
- Remove the bulb from the socket by pressing it in and rotating it counterclockwise until the tabs on the bulb align with the slots in the socket. Pull the bulb out of the socket.
- Insert a new bulb by inserting it into the socket and rotating it until it locks into place.

- Install the socket in the assembly by aligning the tabs on the socket with the slots in the assembly. Push the socket into the assembly and turn the socket clockwise.
- Reinstall the lamp assembly to the body of the vehicle.

### Stop/tail lamp, Tail lamp (Type B, LED)

If the LED lamp does not operate, we recommend you to have the vehicle checked by an authorized HYUNDAI dealer.

## Inside lamp



## Tail lamp, Back-up lamp, Rear fog lamp

1. Turn off the engine.
2. Open the tailgate.
3. Remove the service cover using a flat-blade screwdriver.

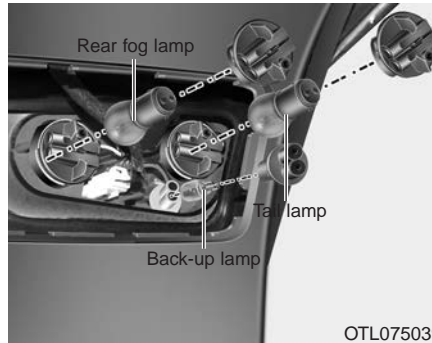

4. Remove the socket from the assembly by turning the socket counterclockwise until the tabs on the socket align with the slots on the assembly.
5. Pull the bulb out of the socket.
6. Insert a new bulb into the socket.
7. Install the socket into the assembly by aligning the tabs on the socket with the slots on the assembly and turning the socket clockwise.
8. Reinstall the lamp assembly to the body of the vehicle

## Tail lamp, Rear fog lamp (Type B, LED)

If the LED lamp does not operate, we recommend you to have the vehicle checked by an authorized HYUNDAI dealer.

### ***Rear fog lamp (if equipped)***

1. Remove the socket from the assembly by turning the socket counterclockwise until the tabs on the socket align with the slots on the assembly.
2. Remove the bulb from the socket by pressing it in and rotating it counterclockwise until the tabs on the bulb align with the slots in the socket. Pull the bulb out of the socket.
3. Insert a new bulb in the socket.
4. Reinstall the light assembly to the body of the vehicle.

### **High mounted stop lamp replacement**

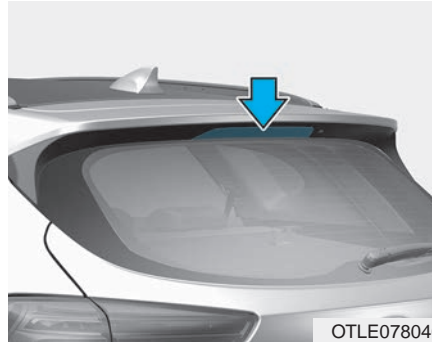

If the high mounted stop lamp does not operate, we recommend that you contact an authorized HYUNDAI dealer.

### **License plate light bulb replacement**

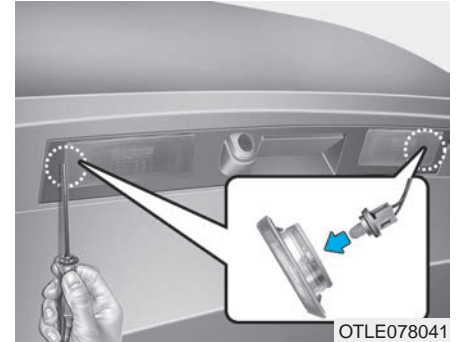

1. Loosen the lens retaining screws with a screwdriver.
2. Remove the lens.
3. Remove the bulb by pulling it straight out.
4. Install a new bulb.
5. Reinstall the lens securely with the lens retaining screws.

## Interior light bulb replacement

### Map lamp and Room lamp (LED type)

■ Map lamp



■ Room lamp

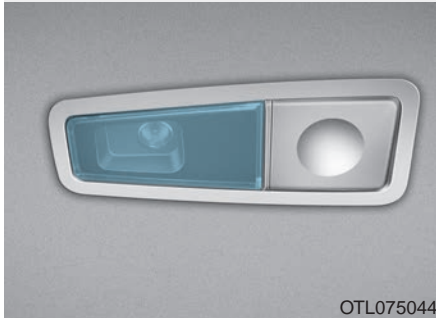

If the LED lamp does not operate, we recommend you to have the vehicle checked by an authorized HYUNDAI dealer.

### Map lamp, Room lamp, Vanity mirror lamp, Tailgate room lamp and glove box lamp

■ Map lamp

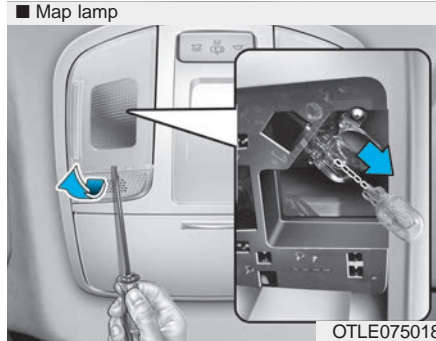

■ Room lamp

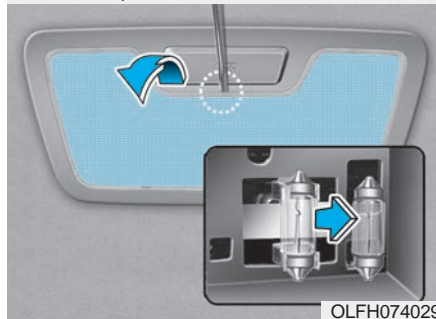

■ Vanity mirror lamp

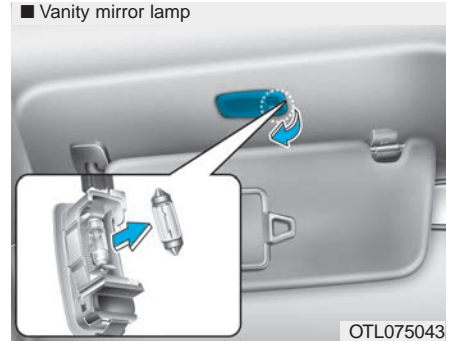

■ Tailgate room lamp

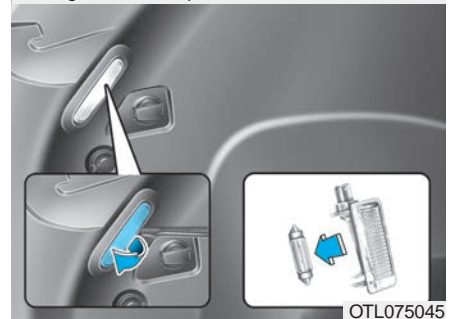

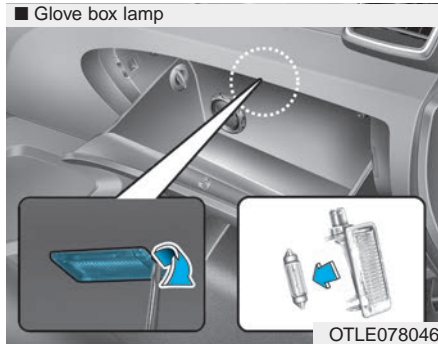

### **NOTICE**

**Be careful not to damage the cover, tab, and plastic housing.**

1. Using a flat-head screwdriver, gently pry the lens from the interior light housing.
2. Remove the bulb by pulling it straight out.
3. Install a new bulb in the socket.
4. Align the lens tabs with the interior light housing notches and snap the lens into place.

## APPEARANCE CARE

### Exterior care

#### *Exterior general caution*

It is very important to follow the label directions when using any chemical cleaner or polish. Read all warning and caution statements that appear on the label.

#### *Finish maintenance*

##### **Washing**

To help protect your vehicle's finish from rust and deterioration, wash it thoroughly and frequently at least once a month with lukewarm or cold water.

If you use your vehicle for off-road driving, you should wash it after each off-road trip. Pay special attention to the removal of any accumulation of salt, dirt, mud, and other foreign materials. Make sure the drain holes in the lower edges of the doors and rocker panels are kept clear and clean.

Insects, tar, tree sap, bird droppings, industrial pollution and similar deposits can damage your vehicle's finish if not removed immediately.

Even prompt washing with plain water may not completely remove all these deposits.

A mild soap, safe for use on painted surfaces, may be used.

After washing, rinse the vehicle thoroughly with lukewarm or cold water. Do not allow soap to dry on the finish.

#### **NOTICE**

- **Do not use strong soap, chemical detergents or hot water, and do not wash the vehicle in direct sunlight or when the body of the vehicle is warm.**
- **Be careful when washing the side windows of your vehicle. Especially, with high-pressure water, water may leak through the windows and wet the interior.**
- **To prevent damage to the plastic parts and lamps, do not clean with chemical solvents or strong detergents.**

#### **WARNING**

##### **Wet brakes**

**After washing the vehicle, test the brakes while driving slowly to see if they have been affected by water. If braking performance is impaired, dry the brakes by applying them lightly while maintaining a slow forward speed.**

### High-pressure washing

- When using high-pressure washers, make sure to maintain sufficient distance from the vehicle.

Insufficient clearance or excessive pressure can lead to component damage or water penetration.

- Do not spray the camera, sensors or its surrounding area directly with a high pressure washer. Shock applied from high pressure water may cause the device to not operate normally.
- Do not bring the nozzle tip close to boots (rubber or plastic covers) or connectors as they may be damaged if they come into contact with high pressure water.



#### NOTICE

- **Water washing in the engine compartment including high pressure water washing may cause the failure of electrical circuits located in the engine compartment.**
- **Never allow water or other liquids to come in contact with electrical/electronic components inside the vehicle as this may damage them.**

#### NOTICE

##### **Matte paint finish vehicle (if equipped)**

Automatic car wash which uses rotating brushes should not be used as this can damage the surface of your vehicle. A steam cleaner which washes the vehicle surface at high temperature may result the oil to adhere and leave stains that is difficult to remove.

Use a soft cloth (e.g. microfiber towel or sponge) when washing your vehicle and dry with a microfiber towel. When you hand wash your vehicle, you should not use a cleaner that finishes with wax. If the vehicle surface is too dirty (sand, dirt, dust, contaminant, etc.), clean the surface with water before washing the car.

## Waxing

Wax the vehicle when water will no longer bead on the paint.

Always wash and dry the vehicle before waxing. Use a good quality liquid or paste wax, and follow the manufacturer's instructions. Wax all metal trim to protect it and to maintain its luster. Removing oil, tar, and similar materials with a spot remover will usually strip the wax from the finish. Be sure to re-wax these areas even if the rest of the vehicle does not yet need waxing.

### NOTICE

- Wiping dust or dirt off the body with a dry cloth will scratch the finish.
- Do not use steel wool, abrasive cleaners, or strong detergents containing highly alkaline or caustic agents on chrome-plated or anodized aluminum parts. This may result in damage to the protective coating and cause discoloration or paint deterioration.

### NOTICE

#### Matte paint finish vehicle (if equipped)

**Do not use any polish protector such as a detergent, an abrasive and a polish. In case wax is applied, remove the wax immediately using a silicon remover and if any tar or tar contaminant is on the surface use a tar remover to clean. However, be careful not to apply too much pressure on the painted area.**

## Finish damage repair

Deep scratches or stone chips in the painted surface must be repaired promptly. Exposed metal will quickly rust and may develop into a major repair expense.

### NOTICE

**If your vehicle is damaged and requires any metal repair or replacement, be sure the body shop applies anti-corrosion materials to the parts repaired or replaced.**

### NOTICE

#### Matte paint finish vehicle (if equipped)

In case of matte paint finish vehicles, it is impossible to modify only the damaged area and repair of the whole part is necessary. If the vehicle is damaged and painting is required, we recommend that you have your vehicle maintained and repaired by an authorized HYUNDAI dealer. Take extreme care, as it is difficult to restore the quality after the repair.



### ***Bright-metal maintenance***

- To remove road tar and insects, use a tar remover, not a scraper or other sharp object.
- To protect the surfaces of bright-metal parts from corrosion, apply a coating of wax or chrome preservative and rub to a high luster.
- During winter weather or in coastal areas, cover the bright metal parts with a heavier coating of wax or preservative. If necessary, coat the parts with non-corrosive petroleum jelly or other protective compound.

### ***Underbody maintenance***

Corrosive materials used for ice and snow removal and dust control may collect on the underbody. If these materials are not removed, accelerated rusting can occur on underbody parts such as the fuel lines, frame, floor pan and exhaust system, even though they have been treated with rust protection.

Thoroughly flush the vehicle underbody and wheel openings with lukewarm or cold water once a month, after off-road driving and at the end of each winter. Pay special attention to these areas because it is difficult to see all the mud and dirt. It will do more harm than good to wet down the road grime without removing it. The lower edges of doors, rocker panels, and frame members have drain holes that should not be allowed to clog with dirt; trapped water in these areas can cause rusting.

### **WARNING**

**After washing the vehicle, test the brakes while driving slowly to see if they have been affected by water. If braking performance is impaired, dry the brakes by applying them lightly while maintaining a slow forward speed.**

### **Aluminum wheel maintenance**

The aluminum wheels are coated with a clear protective finish.

#### **NOTICE**

- **Do not use any abrasive cleaner, polishing compound, solvent, or wire brushes on aluminum wheels.**
- **Clean the wheel when it has cooled.**
- **Use only a mild soap or neutral detergent, and rinse thoroughly with water. Also, be sure to clean the wheels after driving on salted roads.**
- **Do not wash the wheels with high-speed car wash brushes.**
- **Do not use any cleanser containing acid or alkaline detergents.**

### **Corrosion protection**

#### **Protecting your vehicle from corrosion**

By using the most advanced design and construction practices to combat corrosion, we produce cars of the highest quality. However, this is only part of the job. To achieve the long-term corrosion resistance your vehicle can deliver, the owner's cooperation and assistance is also required.

#### **Common causes of corrosion**

The most common causes of corrosion on your car are:

- Road salt, dirt and moisture that is allowed to accumulate underneath the car.
- Removal of paint or protective coatings by stones, gravel, abrasion or minor scrapes and dents which leave unprotected metal exposed to corrosion.

#### **High-corrosion areas**

If you live in an area where your car is regularly exposed to corrosive materials, corrosion protection is particularly important. Some of the common causes of accelerated corrosion are road salts, dust control chemicals, ocean air and industrial pollution.

#### **Moisture breeds corrosion**

Moisture creates the conditions in which corrosion is most likely to occur. For example, corrosion is accelerated by high humidity, particularly when temperatures are just above freezing. In such conditions, the corrosive material is kept in contact with the car surfaces by moisture that is slow to evaporate.

Mud is particularly corrosive because it is slow to dry and holds moisture in contact with the vehicle. Although the mud appears to be dry, it can still retain the moisture and promote corrosion.

High temperatures can also accelerate corrosion of parts that are not properly ventilated so the moisture can be dispersed. For all these reasons, it is particularly important to keep your car clean and free of mud or accumulations of other materials. This applies not only to the visible surfaces but particularly to the underside of the car.

### **To help prevent corrosion**

You can help prevent corrosion from getting started by observing the following:

### **Keep your car clean**

The best way to prevent corrosion is to keep your car clean and free of corrosive materials. Attention to the underside of the car is particularly important.

- If you live in a high-corrosion area — where road salts are used, near the ocean, areas with industrial pollution, acid rain, etc.—, you should take extra care to prevent corrosion. In winter, hose off the underside of your car at least once a month and be sure to clean the underside thoroughly when winter is over.
- When cleaning underneath the car, give particular attention to the components under the fenders and other areas that are hidden from view. Do a thorough job; just dampening the accumulated mud rather than washing it away will accelerate corrosion rather than prevent it. Water under high pressure and steam are particularly effective in removing accumulated mud and corrosive materials.

- When cleaning lower door panels, rocker panels and frame members, be sure that drain holes are kept open so that moisture can escape and not be trapped inside to accelerate corrosion.

### **Keep your garage dry**

Don't park your car in a damp, poorly ventilated garage. This creates a favorable environment for corrosion. This is particularly true if you wash your car in the garage or drive it into the garage when it is still wet or covered with snow, ice or mud. Even a heated garage can contribute to corrosion unless it is well ventilated so moisture is dispersed.

### **Keep paint and trim in good condition**

Scratches or chips in the finish should be covered with "touch-up" paint as soon as possible to reduce the possibility of corrosion. If bare metal is showing through, the attention of a qualified body and paint shop is recommended.

**Bird droppings :** Bird droppings are highly corrosive and may damage painted surfaces in just a few hours. Always remove bird droppings as soon as possible.

### **Don't neglect the interior**

Moisture can collect under the floor mats and carpeting to cause corrosion. Check under the mats periodically to be sure the carpeting is dry. Use particular care if you carry fertilizers, cleaning materials or chemicals in the car.

These should be carried only in proper containers and any spills or leaks should be cleaned up, flushed with clean water and thoroughly dried.

### **Interior care**

#### ***Interior general precautions***

Prevent chemicals such as perfume, cosmetic oil, sun cream, hand cleaner and air freshener from contacting the interior parts because they may cause damage or discoloration. If they do contact the interior parts, wipe them off immediately.

See the instructions that follow for the proper way to clean vinyl.

#### **NOTICE**

**Never allow water or other liquids to come in contact with electrical/electronic components inside the vehicle as this may damage them.**

#### **NOTICE**

**When cleaning leather products (steering wheel, seats etc.), use neutral detergents or low alcohol content solutions. If you use high alcohol content solutions or acid/alkaline detergents, the color of the leather may fade or the surface may get stripped off.**

### ***Cleaning the upholstery and interior trim***

#### **Vinyl (if equipped)**

Remove dust and loose dirt from vinyl with a whisk broom or vacuum cleaner. Clean vinyl surfaces with a vinyl cleaner.

#### **Fabric (if equipped)**

Remove dust and loose dirt from fabric with a whisk broom or vacuum cleaner. Clean with a mild soap solution recommended for upholstery or carpets.

Remove fresh spots immediately with a fabric spot cleaner. If fresh spots do not receive immediate attention, the fabric can be stained and its color can be affected. Also, its fire-resistant properties can be reduced if the material is not properly maintained.

#### **NOTICE**

**Using anything but recommended cleaners and procedures may affect the fabric's appearance and fire-resistant properties.**

#### **Leather (if equipped)**

##### • Feature of Seat Leather

- Leather is made from the outer skin of an animal, which goes through a special process to be available for use. Since it is a natural object, each part differs in thickness or density.

Wrinkles may appear as a natural result of stretching and shrinking depending on the temperature and humidity.

- The seat is made of stretchable fabric to improve comfort.
- The parts contacting the body are curved and the side supporting area is high which provides driving comfort and stability.
- Wrinkles may appear naturally from usage. It is not a fault of the products.

#### **CAUTION**

- **Wrinkles or abrasions which appear naturally from usage are not covered by warranty.**
- **Belts with metallic accessories, zippers or keys inside the back pocket may damage the seat fabric.**
- **Make sure not to wet the seat. It may change the nature of natural leather.**
- **Jeans or clothes which could bleach may contaminate the surface of the seat covering fabric.**

- Caring for the leather seats
  - Vacuum the seat periodically to remove dust and sand on the seat. It will prevent abrasion or damage of the leather and maintain its quality.
  - Wipe the natural leather seat cover often with dry or soft cloth.
  - Use of proper leather protective may prevent abrasion of the cover and helps maintain the color. Be sure to read the instructions and consult a specialist when using leather coating or protective agent.
  - Light colored (beige, cream beige) leather is easily contaminated and the stain is noticeable. Clean the seats frequently.
  - Avoid wiping with wet cloth. It may cause the surface to crack.
- Cleaning the leather seats
  - Remove all contaminations instantly. Refer to instructions below for removal of each contaminant.
  - Cosmetic products (sunscreen, foundation, etc.)  
Apply cleansing cream on a cloth and wipe the contaminate spot. Wipe off the cream with a wet cloth and remove water with a dry cloth.
  - Beverages (coffee, soft drink, etc.)  
Apply a small amount of neutral detergent and wipe until contaminations do not smear.
  - Oil  
Remove oil instantly with absorbable cloth and wipe with stain remover used only for natural leather.
  - Chewing gum  
Harden the gum with ice and remove gradually.

### ***Cleaning the lap/shoulder belt webbing***

Clean the belt webbing with any mild soap solution recommended for cleaning upholstery or carpet. Follow the instructions provided with the soap. Do not bleach or re-dye the webbing because this may weaken it.

### ***Cleaning the interior window glass***

If the interior glass surfaces of the vehicle become fogged (that is, covered with an oily, greasy or waxy film), they should be cleaned with glass cleaner. Follow the directions on the glass cleaner container.

#### **NOTICE**

**Do not scrape or scratch the inside of the rear window. This may result in damage to the rear window defroster grid.**

## EMISSION CONTROL SYSTEM

The emission control system of your vehicle is covered by a written limited warranty. Please see the warranty information contained in the Service Passport in your vehicle.

Your vehicle is equipped with an emission control system to meet all emission regulations.

There are three emission control systems which are as follows.

- (1) Crankcase emission control system
- (2) Evaporative emission control system
- (3) Exhaust emission control system

In order to assure the proper function of the emission control systems, it is recommended that you have your car inspected and maintained by an authorized HYUNDAI dealer in accordance with the maintenance schedule in this manual.

### CAUTION

#### **For the Inspection and Maintenance Test (With Electronic Stability Control (ESC) system)**

- **To prevent the vehicle from misfiring during dynamometer testing, turn the Electronic Stability Control (ESC) system off by pressing the ESC switch.**
- **After dynamometer testing is completed, turn the ESC system back on by pressing the ESC switch again.**

### 1. Crankcase emission control system

The positive crankcase ventilation system is employed to prevent air pollution caused by blow-by gases being emitted from the crankcase. This system supplies fresh filtered air to the crankcase through the air intake hose. Inside the crankcase, the fresh air mixes with blow-by gases, which then pass through the PCV valve into the induction system.

### 2. Evaporative emission control system

The Evaporative Emission Control System is designed to prevent fuel vapors from escaping into the atmosphere.

### **Canister**

Fuel vapors generated inside the fuel tank are absorbed and stored in the onboard canister. When the engine is running, the fuel vapors absorbed in the canister are drawn into the surge tank through the purge control solenoid valve.

### **Purge Control Solenoid Valve (PCSV)**

The purge control solenoid valve is controlled by the Engine Control Module (ECM); when the engine coolant temperature is low during idling, the PCSV closes so that evaporated fuel is not taken into the engine. After the engine warms-up during ordinary driving, the PCSV opens to introduce evaporated fuel to the engine.

### **3. Exhaust emission control system**

The Exhaust Emission Control System is a highly effective system which controls exhaust emissions while maintaining good vehicle performance.

#### **Vehicle modifications**

This vehicle should not be modified. Modification of your vehicle could affect its performance, safety or durability and may even violate governmental safety and emissions regulations.

In addition, damage or performance problems resulting from any modification may not be covered under warranty.

- If you use unauthorized electronic devices, it may cause the vehicle to operate abnormally, wire damage, battery discharge and fire. For your safety, do not use unauthorized electronic devices.

### **Engine exhaust gas precautions (carbon monoxide)**

- Carbon monoxide can be present with other exhaust fumes. Therefore, if you smell exhaust fumes of any kind inside your vehicle, have it inspected and repaired immediately. If you ever suspect exhaust fumes are coming into your vehicle, drive it only with all the windows fully open. Have your vehicle checked and repaired immediately.

#### **WARNING**

**Engine exhaust gases contain carbon monoxide (CO). Though colorless and odorless, it is dangerous and could be lethal if inhaled. Follow the instructions following to avoid CO poisoning.**



- Do not operate the engine in confined or closed areas (such as garages) any more than what is necessary to move the vehicle in or out of the area.
- When the vehicle is stopped in an open area for more than a short time with the engine running, adjust the ventilation system (as needed) to draw outside air into the vehicle.
- Never sit in a parked or stopped vehicle for any extended time with the engine running.
- When the engine stalls or fails to start, excessive attempts to restart the engine may cause damage to the emission control system.

### ***Operating precautions for catalytic converters (if equipped)***

#### **WARNING**

- **A hot exhaust system can ignite flammable items under your vehicle. Do not park, idle, or drive the vehicle over or near flammable objects, such as dry grass, paper, leaves, etc.**
- **The exhaust system and catalytic system are very hot while the engine is running or immediately after the engine is turned off. Keep away from the exhaust system and catalytic, you may get burned.**

**Also, do not remove the heat sink around the exhaust system, do not seal the bottom of the vehicle or do not coat the vehicle for corrosion control. It may present a fire risk under certain conditions.**

Your vehicle is equipped with a catalytic converter emission control device.

Therefore, the following precautions must be observed:

#### **CAUTION**

- **Use only UNLEADED FUEL for gasoline engine.**
- **Do not operate the vehicle when there are signs of engine malfunction, such as misfire or a noticeable loss of performance.**
- **Do not misuse or abuse the engine. Examples of misuse are coasting with the engine off and descending steep grades in gear with the engine off.**

**(Continued)**

**(Continued)**

- **Do not operate the engine at high idle speed for extended periods (5 minutes or more).**
- **Do not modify or tamper with any part of the engine or emission control system. All inspections and adjustments must be made by an authorized HYUNDAI dealer.**
- **Avoid driving with a very low fuel level. If you run out of gasoline, it could cause the engine to misfire and result in excessive loading of the catalytic converter.**

Failure to observe these precautions could result in damage to the catalytic converter and to your vehicle.

Additionally, such actions could void your warranties.

***Gasoline Particulate Filter (GPF) (if equipped)***

The Gasoline Particulate Filter (GPF) system removes the soot in the exhaust gas.

The GPF system automatically burns (or oxidizes) the accumulated soot in accordance with driving situations, unlike a disposable air filter.

In other words, the accumulated soot is automatically purged out by the engine control system and by the high exhaust-gas temperature at normal/high driving speeds.

However, when the vehicle is continually driven at repeated short distances or driven at low speed for a long time, the accumulated soot may not be automatically removed because of low exhaust gas temperature. In this case, the accumulated soot may reach a certain amount regardless of the soot oxidization process, then the GPF lamp will illuminate.

The Gasoline Particulate Filter (GPF) Lamp stops illuminating, when the driving speed exceeds 80 km/h (50 mph) with engine rpm 1,500 ~ 4,000 and the gear in the 3rd position or above for approximately 30 minutes.

When the GPF lamp starts to blink or the warning message “Check exhaust system” pops up even though the vehicle was driven as mentioned above, we recommend that you have the GPF system checked by an authorized HYUNDAI dealer.

With the GPF lamp blinking for an extended period of time, it may damage the GPF system and lower the fuel economy.

 **CAUTION**

**Gasoline Fuel  
(if equipped with GPF)**

**We recommend you to use only the regulated gasoline fuels, when your vehicle is equipped with the GPF system.**

**When you use other gasoline fuels which contain unspecified additives, they may damage the GPF system and cause exhaust emission problems.**

***Diesel particulate filter (DPF)  
(if equipped)***

The Diesel Particulate Filter (DPF) system removes the soot in the exhaust gas. Unlike a disposable air filter, the DPF system automatically burns (oxidizes) and removes the accumulated soot according to the driving condition. In order words, the active burning by engine control system and high exhaust gas temperature caused by normal/high diving condition burns and removes the accumulated soot.

However, if the vehicle continues to be driven at repeated short distance or driven at low speed for a long time, the accumulated soot may not be automatically removed because of low exhaust gas temperature. More than a certain amount of soot deposited, the malfunction indicator light (  ) illuminates.

When the malfunction indicator light illuminates, it may turn-off after driving the vehicle at more than 60km/h (37 mph) or at more than second gear with 1500~2500 engine rpm for a certain time (for about 25 minutes).

If the malfunction indicator light (  ) continues to be blinked or the warning message “Check exhaust system” illuminates in spite of the procedure, visit a professional workshop and check the DPF system. HYUNDAI recommends to visit an authorized HYUNDAI dealer/service partner.

If you continue to drive with the malfunction indicator light blinking for a long time, the DPF system can be damaged and fuel consumption can be worsen and the engine durability can be worsen by oil dilution.

 **CAUTION**

**Diesel Fuel  
(if equipped with DPF)**

**We recommend you to use only the regulated diesel fuels, when your vehicle is equipped with the DPF system.**

**When you use other diesel fuels, which is high in sulfurs (above 50 ppm) or contains unspecified additives, it may damage the DPF system and cause the white smoke emission.**

***Lean NOx Trap (if equipped)***

The Lean NOx Trap (LNT) system removes the nitrogen oxide in the exhaust gas. The smell can occur in the exhaust gas depending on the quality of the fuel and it can degrade NOx reduction performance, please use the regulated automotive diesel fuel.

**Selective Catalytic Reduction  
(if equipped)**

The Selective Catalytic Reduction (SCR) system is to catalytically convert NOx to Nitrogen and Water by using the reduction agent, the urea solution.

***Urea gauge (if equipped)***



The urea solution gauge indicates the approximate amount of remaining urea solution inside the urea solution tank.

**Low urea warning message  
(if equipped)**

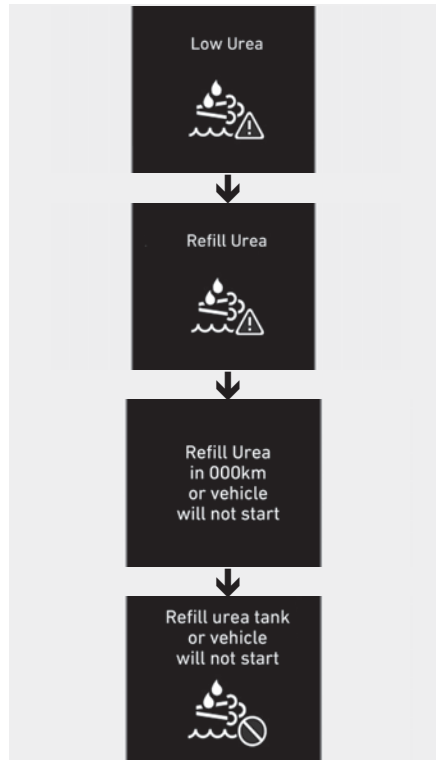

OTM078072L/OTM078075L/OTLE078110/OTLE078111





The lack warning messages of Urea appear below Urea 5.4 liter. When the warning message "Low Urea" is displayed with SCR warning lamp (⚠️), the urea tank needs to be refilled. If not refilled for a considerable mileage, visual warning system will escalate the intensity by displaying the message "Refill Urea" with SCR warning lamp (⚠️).

In this case, the tank soon needs to be refilled. The remaining urea in the tank approaches to too low level the warning message "Refill Urea in 000km or vehicle will not start" with SCR warning lamp (⚠️). "xxx km(mile)" represents the remaining travel distance allowed, so do not continue driving to the limit of the remaining travel distance without refilling.

Otherwise, the vehicle can't be restarted once the engine is turned off by ignition key. Based on the driving pattern, environmental condition and road profile, the deducted remaining mileage may differ from the actual travel distance.

When "Low Urea" or "Refill Urea" message is displayed, add at least 4 liters of urea. When "Refill Urea in 000km or vehicle will not start" message is displayed, fill up urea at least 6 liters. When "Refill Urea tank or vehicle will not start" message is displayed with SCR warning lamp (⚠️), the vehicle can't be restarted once the engine is turned off by ignition key. For the above cases, full replenishment is always recommended.

### Malfunction with the SCR system (if equipped)

	Upon detecting a malfunction		Driving 50 km after detecting a malfunction	
Urea system failure (= no fuel injection)		Urea system failure 		Check urea system 
Incorrect urea detected (= abnormal urea)		Incorrect urea detected 		Refill Urea in 000km or vehicle will not start
Abnormal urea-solution consumption (= post treatment failure)		Check urea system 		Service Urea system in 000km or vehicle will not start

SCR system has malfunction due to disconnected electrical components, incorrect urea and so on.

"xxx km(mile)" represents the remaining travel distance allowed, so do not continue driving to the limit of the remaining travel distance without fixing the source of the malfunction. Otherwise, the vehicle can't be restarted once the engine is turned off by ignition key. In this case, we recommend that the system be inspected by an authorized HYUNDAI dealer.

**Clearing the vehicle-restarting restriction (if equipped)**

No restart			
Low urea solution level		Refill Urea in 000km or vehicle will not start	
Urea system failure (= no fuel injection)		Service Urea system in 000km or vehicle will not start	
Incorrect urea detected (= abnormal urea)		Refill with correct urea in 000km or vehicle will not start	
Abnormal urea-solution consumption (= post treatment failure)		Service Urea system in 000km or vehicle will not start	

Once the inducement system reached to final status and disabled the vehicle restart, it will only be deactivated in case the urea tank is replenished or the malfunctions have been rectified. If the vehicle can't be restarted with "Refill Urea tank or vehicle will not start " message, refill more than 6 liters urea, wait for minutes and try vehicle starting again. If vehicle starting is not possible regardless of urea level, we recommend that the system be inspected by an authorized HYUNDAI dealer.

## Adding the urea solution



### To refill the urea solution from the refill hose

1. Press the ignition switch to the OFF position.
  2. Turn the urea solution tank cap in a counterclockwise direction to open it.
  3. Fully insert the refill hose to add the ISO 22241-specified urea solution over 5 liters or above the mark on the urea solution tank.
- ※ When "Refill Urea tank or vehicle will not start" message is displayed, fill up urea at least 6 liters.

- ※ Pay the great caution not to add the urea solution into the fuel tank. If not, it surely applies adverse impact on the vehicle performance, causing various malfunctions.
  - ※ Never use the urea solution mixture with additives or water. It may allow foreign substances to enter the urea solution tank. If so, it surely applies adverse impact on the vehicle performance, causing various malfunctions.
  - ※ Use only the ISO 22241-specified urea solution. Any unauthorized urea solution surely applies adverse impacts on the vehicle performance, causing various malfunctions.
4. Turn the urea solution tank cap in a clockwise direction to securely close it.

### To refill the urea solution from the refill bottle

1. Press the ignition switch to the OFF position
2. Turn the urea solution tank cap in a counterclockwise direction to open it.
3. Add the ISO 22241-specified urea solution over 5 liters or above the mark on the urea solution tank.
  - ※ Pay the great caution not to add the urea solution into the fuel tank. If not, it surely applies adverse impact on the vehicle performance, causing various malfunctions.
- ※ Pay the great caution not to over-fill the (completely) fulfilled urea solution tank by force while refilling the urea solution from the refill bottle. The over-filled urea solution tank will be expanded when it becomes frozen and this can cause a serious malfunction of the urea solution tank or urea solution system.



- \* Never use the urea solution mixture with additives or water. It may allow foreign substances to enter the urea solution tank. If so, it surely applies adverse impact on the vehicle performance, causing various malfunctions.
  - \* Use only the ISO 22241-specified urea solution. Any unauthorized urea solution surely applies adverse impacts on the vehicle performance, causing various malfunctions.
4. Turn the urea solution tank cap in a clockwise direction to securely close it.

Adding the urea solution: Every approximately 6,000 km (The urea solution consumption is dependent on the road profile, driving pattern and environmental condition)

- \* It takes some time to update the cluster gauges after the UREA injection.

### **WARNING**

- **Do not apply any external impact on the DPF system. It may damage the catalyst, which is equipped inside the DPF system.**
- **Do not arbitrarily modify or manipulate the DPF system by redirecting or lengthen the exhaust pipe. It may adversely impact the DPF system.**
- **Avoid contact with the drained water from the exhaust pipe. The water is slightly acid and harmful to skin. If contacted, thoroughly wash it.**

- **Any arbitrary manipulation or modification of the DPF system may cause a system malfunction. The DPF system is controlled by the complex device.**
- **Wait for the DPF system to cool down before the maintenance service, as it is hot due to the heat generation. Otherwise, it may cause a skin burn.**
- **Add only the specified urea solution, when your vehicle is equipped with the urea solution system.**
- **The urea solution system (i.e. urea solution nozzle, urea solution pump, and DCU) operates for approximately 2 minutes more to eliminate the remaining urea solution inside, even after the ignition switch is pressed to the OFF position. Before the maintenance service, make sure that the urea solution system is completely turned OFF.**

- The poor urea solution or the unauthorized liquids may damage the vehicle components, including the DPF system. Any unverified additives in the urea solution may clog the SCR catalyst and cause other malfunctions, which require the expensive DPF system to be replaced.
- When the urea solution contacts with the eyes or the skin, you should thoroughly wash the contaminated skin area. .
- When you swallow the urea solution, thoroughly rinse your mouth and drink a lot of fresh water. Then, immediately consult a doctor.
- When your cloth is contaminated with the urea solution, immediately change your cloth.

- When you have an allergic reaction to the urea solution, immediately consult a doctor.
- Do not allow a child to contact the urea solution.
- Wipe off any urea solution spillage with water or cloth. When the urea solution is crystalized, wipe it off with the sponge or the cloth, which is dampened in the cold water. When the urea solution spillage is exposed in the air for an extended period of time, it is crystalized in white, damaging the vehicle surface.
- The urea solution is not the fuel additives. Thus, it should not be injected to the fuel tank. Otherwise, it may damage the engine.
- The urea solution is the aqueous solution, which is inflammable, non-toxic, colorless and odorless.

- Store the urea solution tank only in the well-ventilated locations. When the urea solution is exposed to the hot temperature at approximately 50°C for an extended period of time (i.e. under the direct sunlight), the chemical decomposition may occur, emitting the ammonia vapor.

### ***Storing the urea solution***

- It is improper to store the urea solution in the containers made with the certain materials (i.e. aluminum, copper, copper alloy, non-alloyed steel, and galvanized steel). The urea solution dissolves the metal materials, severely damaging the exhaust purification system to be non-repairable.
- Store the urea solution only in the containers made with the following materials.  
(DIN EN 10 088-1/-2/-3-specified CR-Ni steel, Mo-Cr-Ni steel, polypropylene, and polyethylene)

### ***Urea solution purity***

- The following situations may damage the DPF system.
  - Fuels or any unauthorized liquids are added into the urea solution tank.
  - Additives are mixed in the urea solution.
  - Water is added to dilute the urea solution.
- Use only the ISO 22241- or DIN70070-specified urea solution. When any unauthorized urea solution is added to the tank, we recommend you to contact an authorized HYUNDAI dealer.
- When any unauthorized impurities enter the urea solution tank, it may occur the following problems.
  - Increased emission
  - Malfunction with the DPF system
  - Engine failure

Never add the used urea solution, which is drained from the tank (i.e. while maintaining the vehicle). Its purity cannot be guaranteed. Always add the new urea solution.

---

### **Specification of the standard urea solution**

---

Liquid such as diesel, gasoline and alcohol shall never be used for SCR system. Any fluid other than recommended urea solution (conform to ISO22241 or DIN70070) can damage SCR system hardware and deteriorate vehicle emission.

---

**⚠ WARNING**

- When opening the urea solution tank cap at high outside temperatures, ammonia vapors may escape. Ammonia vapors have a pungent smell and primarily cause irritation of the:

- Skin
- Mucous membranes
- Eyes

You may experience a burning sensation in your eyes, nose and throat, as well as coughing and watering of the eyes. Do not inhale ammonia vapors. Do not allow urea solution to come in direct contact with your skin. It is hazardous to your health. Wash any affected areas off with plenty of clean water. If necessary, consult a doctor.

- When handling with urea solution in closed space, ensure good ventilation. When the bottle of urea solution container is opened, pungent smelling fumes may escape.
  - Keep urea solution out of reach of children.
  - When urea solution overflows into vehicle surface, wash out vehicle surface with clean water to prohibit corrosion from occurring.
  - When replenishing, be careful lest the urea solution should overflow.
- In case the vehicle was parked at very low ambient temperature (below 11 degree Celcius) for a long time, the urea solution will be frozen in the urea solution tank. With frozen urea, the tank level may not be detected correctly until the urea solution will be defrosted by activated heater. Incorrect urea or diluted urea can increase the freezing point, and thus defrosting may not be properly done by the heater which is activated below certain temperatures. This phenomenon may cause malfunction of the SCR system which can lead to the prohibition of engine restarting.
  - The time to defrost the urea solution varies in accordance with driving conditions and outside temperatures.



### **CAUTION**

- **If defective urea solution or liquid that is not recommended is supplied, there may be damage on the parts of the vehicle such as processing device. If defective fuel is used, foreign objects will be accumulated to SCR catalyst and cause catalyst pushed away or breaking.**

**After adding the incorrect urea solution, please visit the closest service center as early as possible.**

- **Liquid that are not recommended such as diesel, gasoline, and alcohol shall never be used other than the recommended urea solution that satisfy ISO22241 or DIN70070.**

# Specifications & Consumer information

Dimensions .....	8-2
Engine .....	8-2
Bulb wattage .....	8-3
Air conditioning system .....	8-4
Tires and wheels .....	8-5
Load and speed capacity tires .....	8-6
Gross vehicle weight .....	8-7
Luggage volume .....	8-8
Recommended lubricants and capacities .....	8-9
Recommended engine oil .....	8-12
Recommended SAE viscosity number .....	8-12
Vehicle identification number (VIN) .....	8-14
Vehicle certification label .....	8-14
Tire specification and pressure label .....	8-15
Engine number .....	8-15
Air conditioner compressor label .....	8-16
Refrigerant label .....	8-16
Declaration of conformity .....	8-16
Fuel label .....	8-17
Gasoline engine .....	8-17
Diesel engine .....	8-17

## DIMENSIONS

Item		mm (in)	
Overall length		4,480 (176.38)	
Overall width		1,850 (72.83)	
Overall height	For Western Europe	1,645 (64.76) / 1,650 (66.34) *1	
	Except Western Europe	1,655 (65.16) / 1,660 (65.35) *1	
Front tread	215/70 R16	1,620 (63.78)	
	225/60 R17	1,608 (63.31)	
	225/55 R18	1,608 (63.31)	
	245/45 R19	1,604 (63.15)	
Rear tread	215/70 R16	1,631 (64.21)	
	225/60 R17	1,620 (63.78)	
	225/55 R18	1,620 (63.78)	
	245/45 R19	1,615 (63.58)	
Wheelbase		2,670 (105.12)	

\*1 with roof rack

## ENGINE

Item	1.6 GDI / 1.6 T-GDI	2.0 MPI	2.4 GDI	Smartstream D1.6 / 1.6 48V MHEV	Diesel 2.0 TCI / 2.0 48V MHEV
Displacement cc (cu. in)	1,591 (97.09)	1,999 (121.99)	2,359 (143.96)	1,598 (97.52)	1,995 (121.74)
Bore x Stroke mm (in.)	77X85.4 (3.03X3.36)	81X97 (3.19X3.81)	88X96 (3.46X3.78)	77.0X85.8 (3.03X3.38)	84X90 (3.30X3.54)
Firing order	1-3-4-2	1-3-4-2	1-3-4-2	1-3-4-2	1-3-4-2
No. of cylinders	4. In-line	4. In-line	4. In-line	In-line 4 cylinder	4. In-line

## BULB WATTAGE

Light Bulb				Bulb type	Wattage
Front	Type A, B	Headlamp	Low	H7	55
			High	HB3	60
		Turn signal lamp		PY21W	21
		Position lamp		LED	LED
		Low Beam Assist – Static		H7	55
	Type C, D	Headlamp	Low	LED	LED
			High	LED	LED
		Turn signal lamp		LED	LED
		Position lamp		LED	LED
		Low Beam Assist – Static		LED	LED
	Type A, C	Fog lamp		H8	35
		Daytime running lamp (DRL)		LED	LED
	Type B, D	Fog lamp		HB4	51
		Daytime running lamp (DRL)		LED	LED
Rear	Rear combination lamp	Type A	Tail/Stop	21/5W	21/5
			Tail	W5W	5
			Turn signal	P21W	21
			Back up	W16W	16
			Fog lamp	P21W	21
		Type B	Tail/Stop	LED	LED
			Tail	LED	LED
			Turn signal	P21W	21
			Back up	W16W	16
			Fog lamp	LED	LED
	High mounted stop lamp		LED	LED	
	License plate lamp		W5W	5	





Light Bulb		Bulb type	Wattage
Interior	Map lamp	Type A	W10W
		Type B	LED
	Room lamp	Type A	FESTOON
		Type B	LED
	Sunvisor lamp	FESTOON	5
	Tailgate room lamp	FESTOON	10
Glove box lamp	W5W	5	
Exterior	Puddle lamp		LED
	Side Repeater lamp	Type A	LED
		Type B	W5W

## AIR CONDITIONING SYSTEM

Items	Weight of Volume	Classification
Refrigerant g (oz.)	R-1234yf : 600 (21.16) ± 25 (0.88) R-134a : 600 (21.16) ± 25 (0.88)	R-1234yf (For Europe) R-134a (Except Europe)
Compressor lubricant g (oz.)	100 (3.53) ± 10 (0.35)	PAG

Contact an authorized HYUNDAI dealer for more details.

## TIRES AND WHEELS

Item	Tire size	Wheel size	Inflation pressure bar (kPa, psi)				Wheel lug nut torque kgf-m (lbf-ft, N-m)
			Normal load (  + $\emptyset$ )		Maximum load (  + $\emptyset$ )		
			Front	Rear	Front	Rear	
Full size tire	215/70 R16	6.5J X 16	2.4 (240, 35)	2.4 (240, 35)	2.4 (240, 35)	For Europe : 2.75 (275, 40)  Except Europe : 2.4 (240, 35)	11~13 (79~94, 107~127)
	225/60 R17	7.0J X 17	2.4 (240, 35)	2.4 (240, 35)	2.4 (240, 35)		
	225/55 R18	7.0J X 18	2.4 (240, 35)	2.4 (240, 35)	2.4 (240, 35)		
	245/45 R19	7.5J X 19	2.4 (240, 35)	2.4 (240, 35)	2.4 (240, 35)		
Compact spare tire	T135/90 D17	4.0T X 17	4.2 (420, 60)	4.2 (420, 60)	4.2 (420, 60)	4.2 (420, 60)	
	T135/90 R17	4.0T X 17	4.2 (420, 60)	4.2 (420, 60)	4.2 (420, 60)	4.2 (420, 60)	

### NOTICE

- It is permissible to add 20 kPa (3 psi) to the standard tire pressure specification if colder temperatures are expected soon. Tires typically lose 7 kPa (1 psi) for every 7°C (12°F) temperature drop. If extreme temperature variations are expected, recheck your tire pressure as necessary to keep them properly inflated.
- An air pressure generally decreases, as you drive up to a high-altitude area above sea level. Thus, if you plan to drive a high-altitude area, check the tire pressures in advance. If necessary, inflate them to a proper level (Air inflation per altitude: +10 kPa/1 km (+2.4 psi/1 mile).

 **CAUTION**

**When replacing tires, use the same size originally supplied with the vehicle.  
Using tires of a different size can damage the related parts or make it work irregularly.**

**LOAD AND SPEED CAPACITY TIRES (FOR EUROPE)**

Item	Tire size	Wheel size	Load Capacity		Speed Capacity	
			LI *1	kg	SS *2	km/h
Full size tire	215/70 R16	6.5J X 16	100	800	H	210
	225/60 R17	7.0J X 17	99	775	H	210
					V	240
	225/55 R18	7.0J X 18	98	750	V	240
245/45 R19	7.5J X 19	98	750	W	270	
Compact spare tire	T135/90 D17	4.0T X 17	103	875	M	130
			104	900	M	130
	T135/90 R17	4.0T X 17	104	900	M	130

\*1 LI : LOAD INDEX

\*2 SS : SPEED SYMBOL

## GROSS VEHICLE WEIGHT

### Diesel Engine

kg (lbs)

Item	1.6 TCI (Low)	1.6 TCI (High)				1.6 TCI (48V MHEV)				2.0 TCI (High)		2.0 TCI (48V MHEV)	
	2WD M/T	2WD M/T	2WD DCT	4WD M/T	4WD DCT	2WD M/T	2WD DCT	4WD M/T	4WD DCT	4WD M/T	4WD A/T	4WD M/T	4WD A/T
5 seater	2120 (4674)	2120 (4674)	2145 (4729)	2195 (4839)	2210 (4872)	2150 (4740)	2175 (4795)	2225 (4905)	2240 (4938)	2230 (4916)	2250 (4960)	2230 (4916)	2250 (4960)

### Gasoline Engine (For Europe)

kg (lbs)

Item	1.6 GDI		2.0 MPI				2.4 GDI	1.6 T-GDI			
	2WD M/T	2WD A/T	2WD M/T	2WD A/T	4WD M/T	4WD A/T	4WD A/T	2WD M/T	2WD DCT	4WD M/T	4WD DCT
5 seater	2030 (4475)	2050 (4519)	2060 (4542)	2080 (4586)	2130 (4696)	2150 (4740)	2135 (4707)	2110 (4652)	2140 (4718)	2170 (4784)	2200 (4850)

### Gasoline Engine (Except Europe)

kg (lbs)

Item	1.6 GDI	2.0 MPI				1.6 T-GDI	2.4 GDI
	2WD A/T	2WD M/T	2WD A/T	4WD M/T	4WD A/T	2WD DCT	4WD A/T
5 seater	2030 (4475)	2030 (4475)	2040 (4497)	2100 (4630)	2120 (4674)	2070 (4564)	2140 (4718)

## LUGGAGE VOLUME

l (cu. ft.)

Item		Gasoline Engine/Except Euro 6C Diesel Engine		
		Tire Mobility Kit (TMK)	Compact spare tire	Full size tire
VDA	MIN	513 (18.12)	513 (18.12)	488 (17.23)
	MAX	1,503 (53.08)	1,503 (53.08)	1,478 (52.20)

Item		For Euro 6C Diesel Engine					
		Smartstream D1.6		Smartstream D1.6 (48V MHEV)	2.0 TCI		2.0 TCI (48V MHEV)
		Tire Mobility Kit (TMK)	Compact spare tire	Tire Mobility Kit (TMK)	Tire Mobility Kit (TMK)	Compact spare tire	Tire Mobility Kit (TMK)
VDA	MIN	502 (17.73)	484 (17.09)	459 (16.21)	502 (17.73)	484 (17.09)	459 (16.21)
	MAX	1,492 (52.69)	1,474 (52.05)	1,449 (51.17)	1,492 (52.69)	1,474 (52.05)	1,449 (51.17)

Min : Behind rear seat to upper edge of the seat back.

Max : Behind front seat to roof.

## RECOMMENDED LUBRICANTS AND CAPACITIES

To help achieve proper engine and powertrain performance and durability, use only lubricants of the proper quality. The correct lubricants also help promote engine efficiency that results in improved fuel economy.

These lubricants and fluids are recommended for use in your vehicle.

	Lubricant	Volume	Classification	
Engine oil *1 *2 (drain and refill)  Recommends 	Gasoline 1.6 GDI	3.6 l (3.8 US qt.)	ACEA C2/C3	
	Gasoline 1.6 T-GDI	4.5 l (4.76 US qt.)		
	Gasoline 2.0 MPI	4.0 l (4.23 US qt.)	For Middle East, Morocco, Egypt	SAE 5W-30 / ACEA A5/B5 *3
			Except Middle East, Morocco, Egypt	SAE 5W-20 / API Latest (ILSAC Latest)
	Gasoline 2.4 GDI	4.8 l (5.07 US qt.)	ACEA A5/B5 *3	
	Smartstream D1.6 TCI /1.6 48V MHEV	4.4 l (4.65 US qt.)	ACEA C5 or C2 or C3	
	Diesel 2.0 TCI /2.0 48V MHEV	7.6 l (8.03 US qt.)	with DPF	ACEA C2 or C3
without DPF			ACEA A3/B4	
Manual transaxle fluid	Gasoline 1.6 GDI	1.6~1.7 l (1.7~1.8 US qt.)	HK SYN MTF 70W (SK) SPIRAX S6 GHME 70W (H.K.SHELL) GS MTF HD 70W (GS CALTEX) (API GL-4, SAE 70W)	
	Gasoline 1.6 T-GDI	2WD : 1.5~1.6 l (1.6~1.7 US qt.)		
	Gasoline 2.0 MPI	4WD : 1.4~1.5 l (1.5~1.6 US qt.)		
	Smartstream D1.6 TCI (Low power)	1.5~1.6 l (1.6~1.7 US qt.)		
	Smartstream D1.6 TCI (High power)/1.6 48V MHEV	1.8~1.9 l (1.9~2.0 US qt.)		
	Diesel 2.0 TCI/2.0 48V MHEV	1.8~1.9 l (1.9~2.0 US qt.)		

## Specifications & Consumer information

Lubricant		Volume	Classification
Automatic transaxle fluid	Gasoline 1.6 GDI 2WD	6.7 l (7.08 US qt.)	MICHANG ATF SP-IV, SK ATF SP-IV, NOCA ATF SP-IV, HYUNDAI genuine ATF SP-IV
	Gasoline 2.0 MPI 2WD	7.3 l (7.71 US qt.)	
	Gasoline 2.0 MPI 4WD	7.1 l (7.50 US qt.)	
	Gasoline 2.4 GDI 4WD	6.7 l (7.08 US qt.)	
	Diesel 2.0 TCI /2.0 48V MHEV	7.0 l (7.40 US qt.)	
Dual clutch transmission fluid		1.9~2.0 l (2.01~2.11 US qt.)	HK DCTF 70W (SK) SPIRAX S6 GHME 70W DCTF (H.K.SHELL) GS DCTF HD 70W (GS CALTEX) (API GL-4, SAE 70W)
Engine coolant	Gasoline 1.6 GDI A/T	7.1 l (7.50 US qt.)	Mixture of antifreeze and water (Phosphate-based Ethylene glycol coolant for aluminum radiator)
	Gasoline 1.6 GDI M/T	7.3 l (7.71 US qt.)	
	Gasoline 1.6 T-GDI	7.2 l (7.61 US qt.)	
	Gasoline 2.0 MPI A/T	6.9 l (7.29 US qt.)	
	Gasoline 2.0 MPI M/T	7.0 l (7.40 US qt.)	
	Gasoline 2.4 GDI A/T	7.1 l (7.50 US qt.)	
	Smartstream D1.6 TCI /1.6 48V MHEV M/T	7.1 l (7.50 US qt.)	
	Smartstream D1.6 TCI /1.6 48V MHEV DCT	7.5 l (7.93 US qt.)	
	Diesel 2.0 TCI /2.0 48V MHEV	8.5~8.8 l (8.98~9.3 US qt.)	
Brake/Clutch fluid		0.7~0.8 l (0.74~0.85 US qt.)	FMVSS116 DOT-3 or DOT-4

Lubricant		Volume	Classification
Rear differential oil (4WD)		0.53~0.63 / (0.56~0.67 US qt.)	HYPOID GEAR OIL API GL-5, SAE 75W/85 (SK HCT-5 GEAR OIL 75W/85 or EQUIVALENT)
Transfer case oil (4WD)	Gasoline 1.6 T-GDI / Gasoline 2.0 MPI (M/T <sup>*4</sup> ) / Smartstream D1.6 TCI /1.6 48V MHEV	0.48~0.52 / (0.51~0.55 US qt.)	
	Gasoline 2.0 MPI (A/T <sup>*4</sup> ) / Gasoline 2.4 GDI / Diesel 2.0 TCI /2.0 48V MHEV	0.42~0.47 / (0.44~0.5 US qt.)	
Fuel		58 / (61.3 US qt.) <sup>*5</sup> 62 / (65.51 US qt.)	Refer to "Fuel requirements" in Foreword chapter
Urea (Diesel only, if equipped)		14 / (14.8 US qt.)	ISO22241 DIN70070

<sup>\*1</sup> : Refer to the recommended SAE viscosity numbers on the next page.

<sup>\*2</sup> : Engine oils labeled Energy Conserving Oil are now available. Along with other additional benefits, they contribute to fuel economy by reducing the amount of fuel necessary to overcome engine friction. Often, these improvements are difficult to measure in everyday driving, but in a year's time, they can offer significant cost and energy savings.

<sup>\*3</sup> : If the ACEA A5/B5 engine oil is not available in your country, you are able to use ACEA A3/B3, A3/B4.

<sup>\*4</sup> : M/T : Manual transaxle, A/T : Automatic transaxle

<sup>\*5</sup> : For MHEV (Mild Hybrid)



## Recommended engine oil (For Europe)

Supplier	Product	
	Gasoline Engine	Diesel Engine
Shell	ACEA C2/C3 : Helix Ultra ECT C2/C3 0W30	ACEA C3 : HELIX ULTRA AP 5W30
	ACEA A5/B5 : Helix Ultra AH 5W30, Helix Ultra A5/B5 0W30	ACEA C2 : HELIX ULTRA AP-L 5W30

## Recommended SAE viscosity number

Engine oil viscosity (thickness) has an effect on fuel economy and cold weather operating (engine start and engine oil flowability). Lower viscosity engine oils can provide better fuel economy and cold weather performance, however, higher viscosity engine oils are required for satisfactory lubrication in hot weather. Using oils of any viscosity other than those recommended could result in engine damage.

 **CAUTION**

**Always be sure to clean the area around any filler plug, drain plug, or dipstick before checking or draining any lubricant. This is especially important in dusty or sandy areas and when the vehicle is used on unpaved roads. Cleaning the plug and dipstick areas will prevent dirt and grit from entering the engine and other mechanisms that could be damaged.**

When choosing an oil, consider the range of temperature your vehicle will be operated in before the next oil change. Proceed to select the recommended oil viscosity from the chart.

		Temperature Range for SAE Viscosity Numbers								
Temperature		°C	-30	-20	-10	0	10	20	30	40
		(°F)	-10	0	20	40	60	80	100	
Gasoline Engine Oil	1.6 GDI, T-GDI	20W-50								
		15W-40								
	10W-30									
	5W-30, 5W-40									
	2.4 GDI	20W-50								
2.0 MPI (for Middle East, Morocco, Egypt)	15W-40									
	10W-30									
2.0 MPI (for Europe)	0W-40, 5W-20, 5W-30, 5W-40									
2.0 MPI (except Europe, for Russia)	20W-50									
	15W-40									
	10W-30									
		5W-20, 5W-30								
Diesel Engine Oil	Smartstream D1.6 /1.6 48V MHEV	10W-30								
		5W-30								
	0W-20/30									
	2.0 TCI /2.0 48V MHEV	10W-30/40								
5W-30/40										
		0W-30/40								

## VEHICLE IDENTIFICATION NUMBER (VIN)

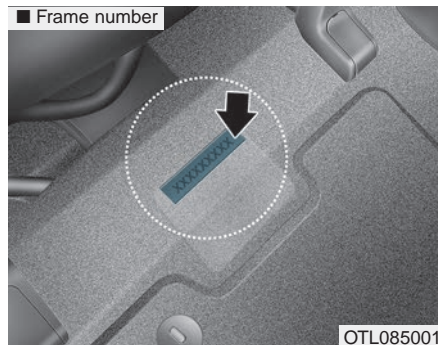

The vehicle identification number (VIN) is the number used in registering your vehicle and in all legal matters pertaining to its ownership, etc. The number is punched on the floor under the passenger seat. To check the number, open the cover.

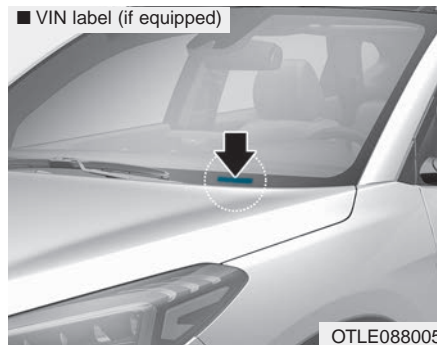

The VIN is also on a plate attached to the top of the dashboard. The number on the plate can easily be seen through the windshield from outside.

## VEHICLE CERTIFICATION LABEL

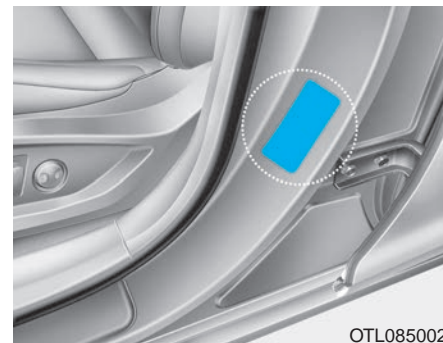

The vehicle certification label attached on the driver's (or front passenger's) side center pillar gives the vehicle identification number (VIN).

## TIRE SPECIFICATION AND PRESSURE LABEL

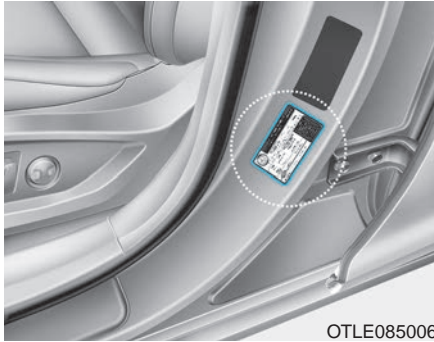

The tires supplied on your new vehicle are chosen to provide the best performance for normal driving.

The tire label located on the driver's side center pillar gives the tire pressures recommended for your vehicle.

## ENGINE NUMBER

■ Smartstream D1.6 / 1.6 48V MHEV

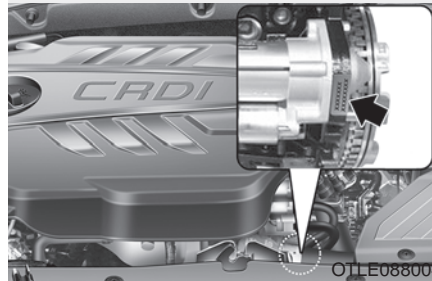

■ Diesel 2.0 TCI / 2.0 48V MHEV

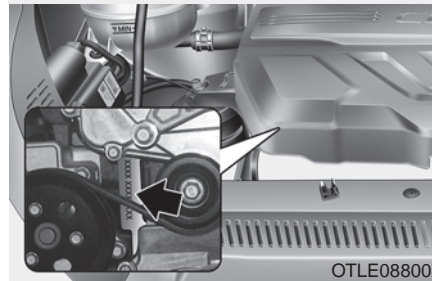

■ Gasoline 2.0 MPI

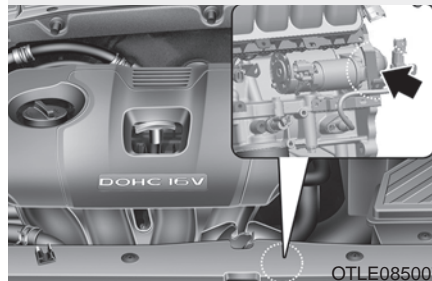

■ Gasoline 1.6 GDI / 1.6 T-GDI

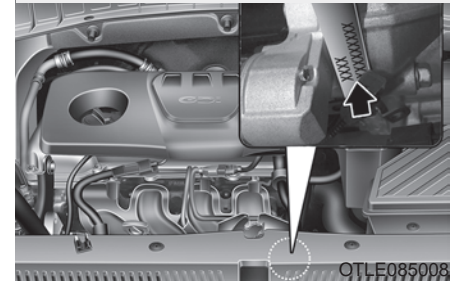

■ Gasoline 2.4 GDI

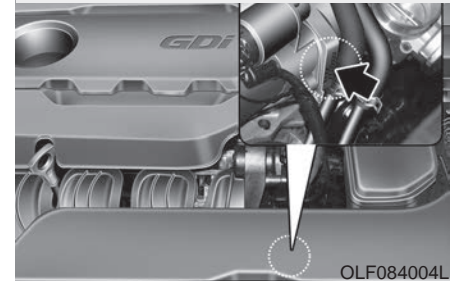

The engine number is stamped on the engine block as shown in the drawing.

## AIR CONDITIONER COMPRESSOR LABEL

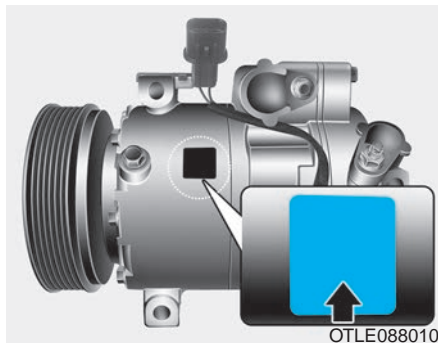

A compressor label informs you the type of compressor your vehicle is equipped with such as model, supplier part number, production number, refrigerant and refrigerant oil.

## REFRIGERANT LABEL



The refrigerant label provides information such as refrigerant type and amount.

The label is located on the underside of the hood.

## DECLARATION OF CONFORMITY (IF EQUIPPED)

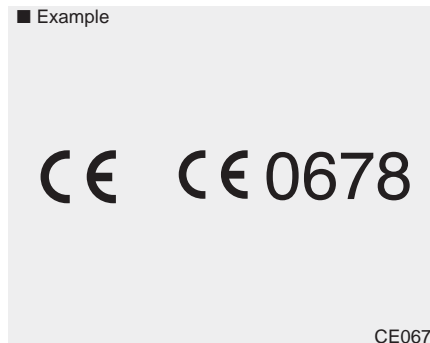

The radio frequency components of the vehicle comply with requirements and other relevant provisions of Directive 1995/5/EC.

Further information including the manufacturer's declaration of conformity is available on HYUNDAI web site as follows;

<http://service.hyundai-motor.com>

## FUEL LABEL (IF EQUIPPED)

### Gasoline engine

The fuel label is attached on the fuel filler door.

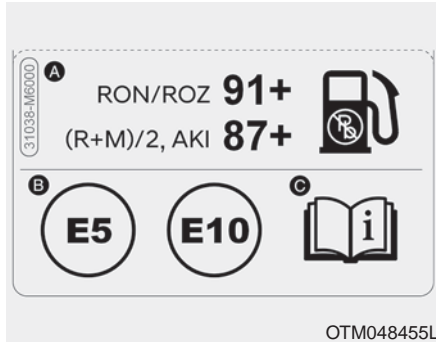

- A. Octane rating of unleaded gasoline
- 1) RON/ROZ : Research Octane Number
  - 2) (R+M)/2, AKI : Anti Knock Index
- B. Identifiers for Gasoline-type Fuels
- \* This symbol means usable fuel. Do not use any other fuel.
- C. For further details, refer to the “Fuel Requirement” in the Introduction chapter.

### Diesel engine

The fuel label is attached on the fuel filler door.

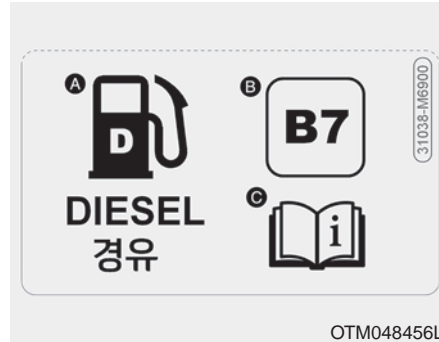

- A. Fuel : Diesel
- B. Identifiers for FAME containing Diesel-type Fuels
- \* This symbol means usable fuel. Do not use any other fuel.
- C. For further details, refer to the “Fuel Requirement” in the Introduction chapter.

# Appendix

## Bulgarian

Шофиране през зимата .....	A-2
Система за задържане на деца (CRS).....	A-5

## Hungarian

Téli vezetés .....	A-9
Biztonsági gyermekülés (CRS).....	A-11

## Icelandic

Vetrarakstur.....	A-15
Barnabílstólar (CRS) .....	A-18

## Polish

Jazda zimą.....	A-22
Urządzenie przytrzymujące dla dzieci (CRS).....	A-25

## ШОФИРАНЕ ПРЕЗ ЗИМАТА (BULGARIAN)

Тежките зимни атмосферни условия могат да предизвикат по-голямо износване и други проблеми. За да сведете до минимум проблемите, свързани с шофирането през зимата, следвайте препоръките по-долу:

### Сняг или поледица

За да карате своето превозно средство при дълбока снежна покривка може да се наложи да използвате зимни гуми или да поставите вериги върху тях. Ако са необ ходими зимни гуми, трябва да изберете гуми със същия размер и вид като тези на оригиналните гуми.

В противен случай това може да се отрази неблагоприятно на безопасността и експлоатацията на Вашия автомобил. Освен това карането с висока скорост, бързото ускорение, внезапното натискане на спирачки и резките завои крият сериозни опасности.

При забавяне на скоростта, използвайте доколкото е възможно спирачките на двигателя. Внезапното натискане на спирачки на заснежена или заледена настилка може да предизвика занасяне. Трябва да под държате достатъчна дистанция между автомобила, който се движи пред Вас, и Вашия автомобил.

Освен това натискайте спирачката леко. Следва да се отбележи че инсталирането на веригите върху гума та ще позволи прилагането на по-голяма движеща сила, но няма да предотврати занасянето встрани.

### К СВЕДЕНИЮ

**Веригите за гуми не са позволени във всички държави. Проверете норма тивната уредба в своята страна преди да поставите вериги за гуми.**



## Гуми за сняг

Ако поставите гуми за сняг на своя авто- мобил се уверете, че това са радиалнигуми със същия размер и товарен индекс като тези на оригиналните гуми. Поставете гуми за сняг на всичките четири колела, за да балансирате експлоатацията на своя автомобил във всякакви атмосферни условия. Имайте предвид, че тягата на гумите за сняг върху суха настилка не може да бъде толкова голяма колкото тази на оригиналните гуми. Следва да карате внимателно, дори когато пътищата са почистени. Консултирайте се с доставчика на гуми за максималната препоръчителна скорост.

### ОСТОРОЖНО

#### Размер на гумите за сняг

Гумите за сняг следва да са равностойни по размер и тип на тези на стандартните гуми на автомобила. В противен случай това може да се отрази неблагоприятно на безопасността и експлоатацията на Вашия автомобил.

*Не монтирайте гуми с шипове, преди да сте проверили местните, национални и общински разпоредби за възможни ограничения в тяхната употреба.*

## Вериги за гуми



Тъй като страниците на радиалните гуми са по-тънки, те могат да се повредят, ако върху тях се монтират някои видове вериги за сняг. Ето защо се препоръчва използването на гуми за сняг, а не на вериги за сняг. Не поставяйте вериги върху автомобилни, чиито колела са с алуминиеви джанти; веригите за сняг могат да повредят колелата. Ако трябва да се използват вериги за сняг, използвайте телени вериги с дебелина от поне 15 мм.

Повредата на Вашия автомобил вследствие на неправилната употреба на вериги за сняг не е в обхвата на гаранцията на Вашия автомобил.

Вериги за гуми трябва да се инсталират само на предните гуми.



### ВНИМАНИЕ

- Уверете се, че размерът и видът на веригите са правилните за Вашите гуми. Неправилните вериги за сняг могат да повредят каросерията и окачването на автомобила и този тип повреда може да не е в обхвата на производствената гаранция за Вашия автомобил.

(продолжение)

(продолжение)

Също така куките за свързване на веригите за сняг могат да се повредят от намиращите се в контакт с тях автомобилни части, като това може да доведе до разхлабването им. Уверете се, че веригите за сняг са от клас S според класификацията на Дружеството на автомобилните инженери (SAE).

- Винаги проверявайте дали веригите са били поставени правилно след като изминете около 0,5 до 1 км, за да се уверите в безопасното им поставяне. Затегнете веригите или ги поставете отново, ако са се разхлабили.

### Монтиране на вериги

Когато инсталирате веригите, следвайте инструкциите на производителя и ги затегнете максимално. Карайте бавно с инсталирани вериги. Ако чуете, че веригите са навлезли в контакт с каросерията или шасито, спрете и ги затегнете. Ако те все още са в контакт, намалете скоростта до преустановяване на контакта. Свалете веригите веднага, щом започнете да карате по почистените пътища.



### ОСТОРОЖНО

#### Поставяне на вериги

Когато поставите вериги за сняг, паркирайте автомобила на равно място далеч от пътното движение. Включете аварийните светлини и поставете светлоотразителния триъгълник зад автомобила, ако разполагате с такъв. Винаги паркирайте автомобила в паркинг, дръпнете ръчната спирачка и изключете двигателя преди да поставите веригите за сняг.

### ОСТОРОЖНО

#### Вериги за гуми

- Използването на вериги може да се отрази неблагоприятно на работата на Вашия автомобил.
- Не надвишавайте пределната скорост, препоръчана от производителя, или скоростта от 30 км/ч, което е по-ниско.
- Карайте внимателно и избягвайте неравности, дупки, резки завои и други опасности на пътя, които могат да накарат автомобила да подскача.
- Избягвайте резките завои или използването на спирачки, ако колелата са блокирани.

### ВНИМАНИЕ

- Веригите с грешен размер или тези, които са неправилно инсталирани, могат да повредят спирачните накладки, окачването, каросерията и колелата.
- Спрете и затегнете веригите повторно винаги, щом ги чуete да удрят автомобила.

## СИСТЕМА ЗА ЗАДЪРЖАНЕ НА ДЕЦА (CRS) (BULGARIAN)

Нашите препоръки: Децата винаги отзад

### ОСТОРОЖНО

Винаги привързвайте правилно децата в автомобила. Децата на всяка възраст са в по-голяма безопасност, когато пътуват на задните седалки. Не поставяйте никога насочена назад система за задържане на деца на предната пасажерска седалка, освен ако еърбегът не е деактивиран.

**Подходяща за всяка позиция на седалка за системи с колан и системи за задържане на деца ISOFIX съгласно регулациите ECE**

Тегловна група	Размерен клас	Закрепване	Позиции на ISOFIX в автомобила			
			Преден пасажер	Задна външна седалка (От страната на водача)	Задна външна седалка (От страната на пасажера)	Задна средна седалка
Седалка-кошче	F	ISO/L1	-	X	X	-
	G	ISO/L2	-	X	X	-
0 : ДО 10кг	E	ISO/R1	-	IL	IL	-
0+ : ДО 13кг	E	ISO/R1	-	IL	IL	-
	D	ISO/R2	-	IL	IL	-
	C	ISO/R3	-	IL	IL	-
I : 9 до 18кг	D	ISO/R2	-	IL	IL	-
	C	ISO/R3	-	IL	IL	-
	B	ISO/F2	-	IUF + IL	IUF + IL	-
	B1	ISO/F2X	-	IUF + IL	IUF + IL	-
	A	ISO/F3	-	IUF + IL	IUF + IL	-

IUF = Подходяща за насочени напред системи за задържане на деца ISOFIX от универсална категория одобрена за употреба в тегловната група.

IL = Подходяща за конкретни системи за задържане на деца ISOFIX, указани в приложения списък. Тези системи за задържане на деца на ISOFIX са от категориите "конкретен автомобил", "ограничени" или "полуавтоматични".

X = Позиция на ISOFIX неподходяща за система за задържане на деца ISOFIX в тази тегловна група /или този размерен клас.

\* Както ISO/R2, така и ISO/R3 могат да бъдат настроени само в най-предната позиция на пасажерската седалка.

\* Размерни класове и закрепвания на система за задържане на деца ISOFIX

A - ISO/F3: Насочена напред система за задържане на деца с пълна височина за малко дете (височина 720 мм)

B - ISO/F2: Насочена напред система за задържане на деца с намалена височина за малко дете (височина 650 мм)

B1 - ISO/F2X: Насочена напред система за задържане на деца с втора версия на формата на задната повърхност с намалена височина за малко дете (височина 650 мм)

C - ISO/R3: Насочена назад система за задържане на деца с пълна височина за малко дете

D - ISO/R2: Насочена назад система за задържане на деца с намалена височина за малко дете

E - ISO/R1: Бебешка насочена назад система за задържане на деца

F - ISO/L1: Лява странично разположена позиция на система за задържане на деца (седалка-кошче)

G - ISO/L2: Дясна странично разположена позиция на система за задържане на деца (седалка-кошче)

**Подходяща за всяка позиция за “универсална” категория системи за задържане на деца с колан съгласно регулациите ECE**

Тегловна група		Позиция на сядане			
		Преден пасажер външно положение	Втори ред седалки		
			Външна лява	Средна (3- ТОЧКОВ КОЛАН)	Външна дясна
Група 0 (0-9 месеца)	до 10 кг	U*	U	U	U
Група 0 + (0-2 години)	до 13 кг	U*	U	U	U
Група I (9 месеца - 4 години)	9 до 18 кг	U*	U	U	U
Група II (15 до 25 кг)	15 до 25 кг	U*	U	U	U
Група III (22 до 36 кг)	22 до 36 кг	U*	U	U	U

U : Подходяща за “универсална” категория системи за задържане на деца одобрена за употреба в тази тегловна група

U\* : Подходяща за “универсална” категория системи за задържане на деца с облегалка регулирана в най-изправена позиция

**Системи за задържане на деца i-Size съгласно регулациите ECE**

Тегловна група	Позиция на сядане			
	Преден пасажер външно положение	Втори ред седалки		
		Външна лява	Средна	Външна дясна
Системи за задържане на деца i-size	X	i-U	X	i-U

i-U : Подходящи за насочени напред и назад “универсални” системи за задържане на деца i-Size

i-UF : Подходящи само за насочени напред “универсални” системи за задържане на деца i-Size

X : Позиция на седалката неподходяща за системи за задържане на деца i-size

## TÉLI VEZETÉS (HUNGARIAN)

Télen a nehéz időjárási feltételek nagyobb elhasználódást és más problémákat eredményezhetnek. A téli vezetés problémáinak csökkentése érdekében célszerű követnie a következő javaslatokat:

### Havas vagy jeges útviszonyok

Mély hóban közlekedéshez szükség lehet téli gumiabroncsok használatára vagy kerekeire hólánc felszerelésére. Ha téli gumiabroncsokra van szüksége, a gyárilag felszerelttel megegyező méretű és típusú gumiabroncsot kell választani. Ennek figyelmen kívül hagyása hátrányosan befolyásolja gépkocsija biztonságát és vezethetőségét. Ezen túlmenően a nagy sebességű haladás, a hirtelen gyorsítás, a hirtelen fékezés és a gyors kanyarvétel nagyon veszélyes gyakorlat.

Lassításkor a lehető legjobban használja ki motorja fékhatását. Havas vagy jeges úton a hirtelen fékezés megcsúszást okozhat.

Elegendően nagy követési távolságot kell tartania saját gépkocsija és az Ön előtt haladó jármű között. Tehát óvatosan fékezzen. Jegyezze meg, hogy hólánc használatakor megnő a hajtóerő, de nem segít az oldalra kicsúszás elkerülésében.

### MEGJEGYZÉS

**A hólánc nem legális minden országban. Ellenőrizze az Ön országának törvényeit, mielőtt felszereli a hóláncot.**

### Téli gumiabroncs

Ha téli gumiabroncsot akar használni, először győződjön meg arról, hogy ezek megfelelő méretű és terhelhetőségű radiál abroncsok. Kifejezetten javasoljuk, hogy mind a négy kerékre szereltesen téli gumiabroncsot, hogy biztosítsa gépkocsija jó vezethetőségét. Ne feledje, hogy a téli gumiabroncsok tapadása száraz úton nem olyan jó, mint a gépkocsira eredetileg felszerelt gumiabroncsoké. Még tiszta úton is óvatosan kell vezetnie.

Tájékozódjon a gumiszerelőnél a megengedett legnagyobb sebességgel kapcsolatban.

### VIGYÁZAT!

#### A téli gumiabroncsok mérete

**A téli gumiabroncsnak mind méretében, mind szerkezetében meg kell egyeznie az eredeti nyárral. Ellenkező esetben gépkocsija biztonsága és vezethetősége kedvezőtlenül változhat.**

*Ne szereltesen fel szöges gumiabroncsot, mielőtt tájékozódna a használatukra, illetve esetleges tiltásukra vonatkozó helyi előírásokról.*

## Hólánc



Mivel a radiál gumiabroncsok oldalfala vékonyabb, megsérülhetnek bizonyos fajtájú hólánc felszerelésétől. Ezért inkább javasoljuk a téli gumiabroncsok használatát, mint a hólánc használatát. Ne szereljen fel hóláncot alumínium keréktárcsás kerékre, mivel a hólánc sérüléseket okozhat a keréktárcsán. Ha mégis hóláncot kellene használnia, használjon 15 mm-es átmérőnél kisebb, kábeltípusú hóláncot. Gépkocsijának a hólánc helytelen használatából eredő kárait nem vonatkozik a garancia.

Csak az első kerekekre szereljen hóláncot.

### ⚠ FIGYELEM!

- **Ügyeljen arra, hogy a hólánc a gumiabroncsaihoz megfelelő méretű és típusú legyen. A nem megfelelő méretű hólánc megrongálhatja gépkocsija karosszériáját és felfüggesztéseit, és erre nem vonatkozik a gépkocsi garanciája. Ezenkívül a hólánc összekötő kapcsai megsérülhetnek a karosszériához ütdéstől, amitől a hólánc meglazulhat, és leeshet a kerékről. Kizárólag az SAE szabvány szerinti „S” osztályú hóláncot használjon.**
- **0,5 - 1km megtétele után ellenőrizze megfelelő elhelyezkedésüket a biztonságos felszerelésük érdekében. Ha meglazultak, húzza meg újra, vagy szerelje fel ismét a hóláncokat.**

## A hólánc felszerelése

A hólánc felszerelésekor figyelmesen kövesse gyártójának utasításait, és a lehető legfeszesebbre húzza meg a láncot. A felszerelt hólánccal lassan közlekedjen. Ha a lánc hozzáverődik a karosszériához vagy az alvázhhoz, álljon meg és feszítsen rajta. Ha még mindig hozzáér, lassítson le annyira, hogy megszűnjön a kontaktus. Haladéktalanul távolítsa el a láncokat, amint tiszta útra ér.

### ⚠ VIGYÁZAT!

#### Hólánc felszerelése

Forgalomtól távol eső sík felületen álljon félre. Kapcsolja be a vészvillogót és tegyen ki elakadásjelző háromszöget a gépkocsi mögé. A hólánc felszerelése előtt mindig kapcsolja P állásba a sebességváltó választókarját, működtesse a rögzítőféket, majd állítsa le a motort.



## VIGYÁZAT!

### Hólánc

- A hólánc használata jelentősen korlátozza a gépkocsi kezelhetőségét.
- Ne lépje túl a 30 km/h sebességet, vagy a hólánc gyártója által meghatározott maximális sebességet. Mindig a kettő közül alacsonyabb értéket tartsa be.
- Vezessen óvatosan, kerülje a bukkanókat, lyukakat, éles kanyarokat és az úton előforduló egyéb veszélyforrásokat, melyek a gépkocsi erős berugózását okozzák.
- Tartózkodjon az éles kanyarvételtől és a blokkoló kerekekkel történő fékezéstől.

## FIGYELEM!

- A nem megfelelő méretű vagy rosszul felszerelt hólánc megrongálhatja gépkocsija féktömlőit, felfüggesztéseit, karosszériáját és a kerekeit.
- Álljon meg és húzza feszesebbre a hólánccokat, ha beleütnek a gépkocsi valamelyik alkatrészébe.

## BIZTONSÁGI GYERMEKÜLÉS (CRS) (HUNGARIAN)

Javaslatunk: A gyermek mindig hátul üljön

## VIGYÁZAT!

Mindig megfelelően rögzítse a gyermeket a járműben. A gyermekek számára minden életkorban biztonságosabb hátul utazni. Soha ne helyezze a hátrafelé néző Gyermekbiztonsági rendszert az első ülésre, hacsak nem kapcsolták ki a légzsákokat.

**Az ISOFIX Gyermekbiztonsági rendszerekhez tartozó üléspozíciók megfelelősége az ECE szabályozások szerint**

Tömeges csoport	Méretkategória	Rögzítés	Jármű ISOFIX pozíciói			
			Első utasoldali	Hátsó (Vezetőoldali)	Hátsó (Utasoldali)	Hátsó középső
Mózeskosár	F	ISO/L1	-	X	X	-
	G	ISO/L2	-	X	X	-
0 : 10 kg-ig	E	ISO/R1	-	IL	IL	-
0+ : 13kg-ig	E	ISO/R1	-	IL	IL	-
	D	ISO/R2	-	IL	IL	-
	C	ISO/R3	-	IL	IL	-
I : 9-től 18 kg-ig	D	ISO/R2	-	IL	IL	-
	C	ISO/R3	-	IL	IL	-
	B	ISO/F2	-	IUF + IL	IUF + IL	-
	B1	ISO/F2X	-	IUF + IL	IUF + IL	-
	A	ISO/F3	-	IUF + IL	IUF + IL	-

IUF = A súlycsoporthoz jóváhagyott univerzális kategóriájú menetirányba néző ISOFIX Gyermekbiztonsági rendszerekhez megfelelő.

IL = A mellékelt listán szereplő bizonyos ISOFIX Gyermekbiztonsági rendszerekhez megfelelő. Ezek a „különleges járművekhez”, illetve „korlátozott” vagy „féluniverzális” kategóriákhoz tartozó ISOFIX CRS rendszerek.

X = az ISOFIX pozíció nem megfelelő az ISOFIX Gyermekbiztonsági rendszerhez ebben a súlycsoportban és/vagy méretkategóriában.

\* Mind az ISO/R2, mind az ISO/R3 alkalmas arra, hogy csak az utasoldali ülés legelső pozíciójába állítsák.

\* ISOFIX Gyermekbiztonsági rendszer méretkategóriák és rögzítések

A - ISO/F3: Menetirányba néző magas, kisgyermek Gyermekbiztonsági rendszer (magasság 720 mm)

B - ISO/F2: Menetirányba néző alacsony, kisgyermek Gyermekbiztonsági rendszer (magasság 650 mm)

B1 - ISO/F2X: Második verziójú alacsony, háttámlás, menetirányba néző kisgyermek Gyermekbiztonsági rendszer (magasság 650 mm)

C - ISO/R3: Hátrafelé néző, magas, kisgyermek Gyermekbiztonsági rendszer

D - ISO/R2: Hátrafelé néző, alacsony, kisgyermek Gyermekbiztonsági rendszer

E - ISO/R1: Hátrafelé néző, csecsemő Gyermekbiztonsági rendszer

F - ISO/L1: Baloldalra néző Gyermekbiztonsági rendszer (mózeskorár)

G - ISO/L2: Jobboldalra néző Gyermekbiztonsági rendszer (mózeskosár)

**Az „univerzális” kategória egyes üléspozícióinak megfelelősége a biztonsági övvel rögzített Gyermekbiztonsági rendszerekhez az ECE szabályozások szerint**

Tömeges csoport		Üléspozíció			
		Első utasoldali Külső	Második sor		
			Bal külső	Középső (3-PONTOS ÖV)	Jobboldali
0. Csoport (0-9 hónap)	10 kg-ig	U*	U	U	U
0+. Csoport (0-2 év)	13kg-ig	U*	U	U	U
I. csoport (9 hónap-4 év)	9-től 18 kg-ig	U*	U	U	U
II. csoport (15-től 25 kg-ig)	15-től 25 kg-ig	U*	U	U	U
III. csoport (22-től 36 kg-ig)	22-től 36 kg-ig	U*	U	U	U

U : A súlycsoporthoz jóváhagyott „univerzális” kategóriájú Gyermekbiztonsági rendszerekhez megfelelő

U\* : A legmagasabb pozícióba állított háttámlával rendelkező „univerzális” kategóriájú Gyermekbiztonsági rendszerekhez megfelelő

**Az ECE szabályozásoknak megfelelő i-Size Gyermekbiztonsági rendszerek**

Tömeges csoport	Üléspozíció			
	Első utasoldali Külső	Második sor		
		Bal külső	Középső	Jobb külső
i-size Gyermekbiztonsági rendszerek	X	i-U	X	i-U

i-U : A menetirányba és hátrafelé néző i-Size „univerzális” Gyermekbiztonsági rendszerekhez megfelelő

i-UF : Kizárólag a menetirányba néző i-Size „univerzális” Gyermekbiztonsági rendszerekhez megfelelő

X : Az üléspozíció nem megfelelő az i-size Gyermekbiztonsági rendszerekhez

## VETRARAKSTUR (ICELANDIC)

Akstur í þungri færð og vetrarveðri leiðir til aukins slits á ökutækinu og skapar ýmis vandamál. Hægt er að draga úr erfiðleikum sem fylgja vetrarakstri ef farið er að þessum ráðleggingum:

### Akstur í snjó eða hálfu

Við akstur í djúpum snjó kann að vera nauðsynlegt að nota vetrarhjólbarða eða setja keðjur á hjólbarðana. Reynist nauðsynlegt að nota vetrarhjólbarða þarf að velja hjólbarða af sömu stærð og gerð og venjulegu hjólbarðarnir. Sé það ekki gert getur það dregið úr öryggi og skert aksturseygileika ökutækisins.

Hraðakstur, skyndileg hröðun, nauðhemplun og krappar beygjur geta enn fremur falið í sér mikla hættu.

Þegar dregið er úr hraða er ráðlegt að beita vélarhemplun sem kostur er. Við nauðhemplun á snævi þöktum eða hálum vegum getur ökutækið hæglega runnið til. Nauðsynlegt er að halda hæfilegri fjarlægð á milli þíns ökutækis og ökutækisins fyrir framan. Alltaf ætti að beita hemlinum mjúklega. Hafa ber í huga að ef keðjur eru settar á hjólbarða fæst aukinn drifkraftur en það hindrar þó ekki að ökutækið renni til hliðanna.

### ATHUGIÐ

**Notkun snjókeðja er ólögleg í sumum ríkjum. Kynnið ykkur gildandi landslög áður en keðjur eru settar upp.**

### Vetrarhjólbardar

Ef vetrarhjólbardar eru settir á ökutækið þarf að gæta þess að nota þverofna hjól- barda af sömu stærð og áspunga og upprunalegu hjólbardarnir. Setjið vetrarhjólbarda á öll fjögur hjólin til að tryggja örugga stýringu ökutækisins við öll veðurskilyrði. Hafið í huga að á auðum vegi kunna vetrarhjólbardar að hafa minna grip en hjólbardarnir sem fylgdu ökutækinu. Því þarf að aka af gætni, jafnvel á auðum vegum. Ráðfærið ykkur við söluaðila hjólbardanna um ráðlagðan hámarkshraða.

#### ⚠ VIÐVÖRUN

##### Stærðir vetrarhjólbarda

Vetrarhjólbardar ættu að vera af sömu stærð og gerð og hjólbardarnir sem fylgdu ökutækinu.

Misræmi á því getur dregið úr öryggi og skert aksturseginnleika ökutækisins.

Áður en negldir hjólbardar eru settir upp er rétt að kynna sér reglugerðir um notkun slíkra hjólbarda í viðkomandi landi, fylki eða sveitarfélagi.

### Keðjur á hjólbarda



Hliðar þverofinna hjólbarda eru þynnri en á öðrum hjólbörðum og sumar gerðir snjókeðja geta því valdið skemmdum á þeim. Því er ráðlegt að nota vetrarhjólbarda fremur en keðjur, ef þess er kostur.

Setjið aldrei keðjur á hjólbarda ökutækja sem búin eru álfelgum þar sem keðjurnar geta valdið skemmdum á felgunum. Ef óhjákvæmilegt reynist að nota keðjur skal nota virkeðjur sem eru innan við 15 mm á þykkt.

Ábyrgðartrygging söluaðila ökutækisins tekur ekki til skemmda sem orsakast af rangri notkun snjókeðja. Snjókeðjur skal aðeins setja á framhjólbardana.

## VARÚÐ

- Gætið þess að snjókeðjurnar séu af þeirri stærð og gerð sem hæfir hjólbörðunum. Notkun snjókeðja af rangri gerð getur valdið skemmdum á yfirbyggingu og fjöðrun ökutækisins og kann að falla utan ábyrgðartryggingar söluaðila ökutækisins. Þá geta festikrókar keðjanna skemmst vegan núnings við íhluti ökutækisins og snjókeðjurnar losnað af hjólbarðanum. Gætið þess að snjókeðjurnar séu með SAE-vottun í S-flokki.
- Eftir um það bil 0,5-1 km akstur skal ævinlega skoða keðjurnar aftur til að tryggja að þær hafi verið settar upp á réttan og öruggan hátt. Herðið keðjurnar eða setjið þær aftur á ef þær hafa losnað.

## Uppsetning á keðjum

Þegar keðjur eru settar á skal fylgja leiðbeiningum framleiðanda og herða keðjurnar eins mikið og unnt er. Þegar keðjur hafa verið settar á skal aka hægt. Ef hljóð heyrst sem bendir til að keðjurnar séu í snertingu við yfirbyggingu eða undirvagn er rétt að nema staðar og herða keðjurnar. Ef snerting virðist enn eiga sér stað skal hægja aksturinn þar til hljóðið þagnar. Takið keðjurnar niður um leið og komið er á rudda og snjólausa vegi.

## VIÐVÖRUN

### Uppsetning á keðjum

Þegar snjókeðjur eru settar upp skal leggja ökutækinu á sléttum fleti fjarri umferð. Kveikið á viðvörunarljósum ökutækisins og setjið príhyrningslaga viðvörunarskilti upp fyrir aftan ökutækið, ef það er tiltækt. Hafið ökutækið ævinlega í stöðuhemli og drepíð á vélinni áður en snjókeðjur eru settar upp.

### VIÐVÖRUN

#### Keðjur á hjólbarða

- Notkun keðja getur skert aksturs- eiginleika ökutækisins.
- Akið ekki hraðar en 30 km/klst. eða samkvæmt ráðlögðum hámarkshraða framleiðanda keðjanna, hvort sem reynist lægra.
- Akið gætilega og sneiðið hjá þústum, holum, kröppum beygjum og öðrum hættum á veginum, sem gætu valdið hristingi ökutækisins.
- Forðist krappar beygjur eða læsta hemlun.

### VARÚÐ

- Séu snjókeðjur af rangri stærð eða rangt upp settar geta þær valdið skemmdum á hemlalögn, fjöðrun, yfirbyggingu og hjólum ökutækisins.
- Hvenær sem hljóð bendir til þess að keðjurnar sláist við ökutækið skal stöðva akstur og herða keðjurnar.

## BARNABÍLSTÓLAR (CRS) (ICELANDIC)

Ráðleggingar okkar: Börn alltaf aftur í

### VIÐVÖRUN

Festu börn alltaf á réttan hátt í ökutækinu. Börn á öllum aldri eru öruggari í aftursætinu. Setjið aldrei afturvísandi barnabílstól í farþegasætið fram í, nema slökkt sé á loftpúðanum.



## Hentugleiki hversrar sætisstöðu fyrir ISOFIX barnabílstóla samkvæmt ECE reglugerðum

Hópflokkur	Stærðarflokkur	Festing	ISOFIX stöður ökutækis			
			Farþegasæti fram í	Ytra sæti aftur í (Ökumannsmegin)	Ytra sæti aftur í (Farþegamegin)	Miðja aftur í
burðarrúm	F	ISO/L1	-	X	X	-
	G	ISO/L2	-	X	X	-
0 : UPP AÐ 10 kg	E	ISO/R1	-	IL	IL	-
0+ : UPP AÐ 13 kg	E	ISO/R1	-	IL	IL	-
	D	ISO/R2	-	IL	IL	-
	C	ISO/R3	-	IL	IL	-
I : 9 til 18 kg	D	ISO/R2	-	IL	IL	-
	C	ISO/R3	-	IL	IL	-
	B	ISO/F2	-	IUF + IL	IUF + IL	-
	B1	ISO/F2X	-	IUF + IL	IUF + IL	-
	A	ISO/F3	-	IUF + IL	IUF + IL	-

IUF = hentar fyrir ISO1 framvísandi barnabílstól af alhliða flokki sem viðurkenndur er til notkunar í fjölhópi.

IL = hentar fyrir tiltekin ISOFIX barnabílstólakerfi sem eru talin upp í viðhengdum lista. Þessi ISOFIX CRS eru fyrir „ákveðin ökutæki“, „takmörkuð“ eða „hálf-alhliða“ flokka.

X = ISOFIX staða hentar ekki fyrir ISOFIX barnabílstólakerfi í þessum fjölhóp og/eða þessum stærðarflokki.

\* Bæði ISO/R2 og ISO/R3 er aðeins hægt að setja upp í fremstu stöðu farþegasætis.

\* ISOFIX barnabílstólakerfi flokka og festingar

A - ISO/F3: Framvísandi barnabílstóll í fullri hæð (hæð 720 mm)

B - ISO/F2: Framvísandi barnabílstóll með skertri hæð (hæð 650 mm)

B1 - ISO/F2X: Önnur útgáfa framvísandi barnabílstóll með skertri hæð og afturlögun (hæð 650 mm)

C - ISO/R3: Afturvísandi barnabílstóll í fullri stærð

D - ISO/R2: Afturvísandi barnabílstóll í fullri stærð

E - ISO/R1: Afturvísandi ungbarnabílstóll

F - ISO/L1: Vinstri hliðarvísandi burðarrúm

G - ISO/L2: Hægri hliðarvísandi burðarrúm

**Hentugleiki hvernar sætisstöðu fyrir barnabílstóla festa með sætisbeltum í „alhliða“ flokki samkvæmt ECE reglugerðum Frammi í ytra farþegasæti**

Hópflokkur		Sætisstaða			
		Frammi í ytra farþegasæti	Önnur röð		
			Ytra sæti vinstra megin	Miðja (3 PUNKTA BELTI)	Ytra sæti hægra megin
Flokkur 0 (0 - 9 mánaða)	upp að 10 kg	U*	U	U	U
Flokkur 0 + (0 - 2 ára)	upp að 13kg	U*	U	U	U
Hópur I (9 mánaða - 4 ára)	9 til 18 kg	U*	U	U	U
Hópur II (15 til 25kg)	15 til 25kg	U*	U	U	U
Hópur III (22 til 36kg)	22 til 36kg	U*	U	U	U

U : Hentar barnabílstól í „almennum flokk“ viðurkenndur til notkunar í þessum fjölhóp

U\* : Hentar fyrir barnabílstól með sætisbak í uppréttustu stöðu í „alhliða“ flokk

## Barnabílstóll í i-stærð samkvæmt ECE reglugerðum

Hópflokkur	Sætisstaða			
	Frammi í ytra farpegasæti	Önnur röð		
		Ytra sæti vinstra megin	Miðja	Ytra sæti hægra megin
barnabílstóll í i-stærð	X	i-U	X	i-U

i-U : Hentar fram- og afturvísandi „alhliða“ barnabílstólum í i-stærð

i-UF : Hentar aðeins framvísandi „alhliða“ barnabílstólum í i-stærð

X : Sætisstaða hentar ekki fyrir barnabílstóla í i-stærð

### JAZDA ZIMĄ (POLISH)

Surowe warunki pogodowe zimą powodują większe zużycie pojazdu i inne problemy. Aby zminimalizować problemy związane z jazdą w zimie, postępuj zgodnie z poniższymi sugestiami:

#### Jazda w warunkach śniegowych i przy oblodzeniu

Aby prowadzić pojazd w głębokim śniegu, może okazać się niezbędne użycie opon zimowych lub zainstalowanie łańcuchów śniegowych. Jeśli potrzebne okażą się opony zimowe, konieczne jest wybranie opon o rozmiarze i typie odpowiadających oponom, w jakie pojazd był pierwotnie wyposażony. Jeśli założone zostaną nieodpowiednie opony, będzie to miało negatywny wpływ na bezpieczeństwo i prowadzenie pojazdu. Ponadto jazda z nadmierną prędkością, gwałtowne przyspieszanie, nagłe hamowanie i ostre skręty będą stanowiły potencjalnie bardzo duże niebezpieczeństwo.

Podczas zwalniania należy w pełni wykorzystać hamowanie silnikiem. Nagłe hamowanie na zaśnieżonej lub oblodzonej drodze może spowodować poślizg pojazdu.

Należy utrzymywać odpowiedni odstęp od pojazdu jadącego z przodu. Hamulców należy używać ostrożnie. Należy pamiętać, że założenie łańcuchów śniegowych zapewni większą siłę napędową, ale nie zapobiegnie ślizganiu się na boki.

#### UWAGA

**Stosowanie łańcuchów śniegowych nie jest zgodne z prawem we wszystkich krajach. Przed założeniem łańcuchów śniegowych należy sprawdzić przepisy danego kraju.**

## Opony zimowe

Kiedy zakładane są opony zimowe, należy upewnić się, że są to opony radialne o takim samym rozmiarze i zakresie obciążeń co pierwotne opony pojazdu. Opony zimowe należy zakładać na wszystkie cztery koła pojazdu, by we wszystkich warunkach pogodowych pojazd pozwalał się prowadzić równomiernie. Należy pamiętać, że przyczepność zapewniana przez opony zimowe na suchej drodze może nie być równie wysoka jak przyczepność pierwotnych opon pojazdu. Pojazd należy prowadzić ostrożnie nawet wtedy, gdy drogi są oczyszczone. Aby poznać informacje na temat zalecanych ograniczeń prędkości dla danych opon, należy skontaktować się ze sprzedawcą opon.

### OSTRZEŻENIE

#### Rozmiar opon zimowych

**Opony zimowe powinny mieć rozmiar i typ odpowiadający standardowym oponom pojazdu. Jeśli tak nie jest, może to mieć negatywny wpływ na bezpieczeństwo i prowadzenie pojazdu.**

*Opony okolicznych nie należy zakładać bez uprzedniego sprawdzenia w przepisach lokalnych, stanowych i miejskich, czy na ich użycie nie są nałożone ograniczenia.*

## Łańcuchy śniegowe (przeciwpoślizgowe)



Ponieważ ścianki boczne opon radialnych są cieńsze, założenie niektórych rodzajów łańcuchów śniegowych może spowodować ich uszkodzenie. Z tego względu zaleca się korzystanie z opon zimowych zamiast łańcuchów śniegowych. Łańcuchów śniegowych nie należy zakładać w pojazdach, które są wyposażone w felgi aluminiowe, ponieważ mogą one powodować uszkodzenia felg. Jeśli użycie łańcuchów śniegowych jest niezbędne, należy zastosować łańcuchy drutowe o grubości poniżej 15 mm.

Uszkodzenia pojazdu spowodowane użyciem niewłaściwych łańcuchów śniegowych nie jest objęte gwarancją producenta pojazdu.

Łańcuchy śniegowe należy instalować jedynie na przednich kołach.

### **OSTROŻNIE**

- Należy upewnić się, że łańcuchy śniegowe mają odpowiedni rozmiar i typ dla opon pojazdu. Zastosowanie niewłaściwych łańcuchów śniegowych może spowodować uszkodzenie nadwozia oraz zawieszenia, a zniszczenia powstałe w ten sposób mogą nie być objęte gwarancją producenta pojazdu. Ponadto, haczyki łączące łańcuchów śniegowych mogą zostać zniszczone na skutek stykania się z elementami samochodu, co może spowodować zsuniecie się łańcuchów z opon. Należy upewnić się, że łańcuchy śniegowe są klasy "S" SAE i posiadają certyfikat.

(Ciąg dalszy)

### (Ciąg dalszy)

- Po przejechaniu ok. 0,5 do 1 km (0,3 do 0,6 mil), dla zachowania bezpieczeństwa, należy zawsze sprawdzić, czy łańcuchy śniegowe zostały poprawnie założone. Jeśli łańcuchy poluzowały się, należy je zacisnąć lub założyć ponownie.

### Zakładanie łańcuchów śniegowych

Zakładając łańcuchy śniegowe należy postępować zgodnie z instrukcjami podanymi przez producenta. Łańcuchy należy założyć tak ciasno, jak to tylko możliwe. Kiedy łańcuchy są już założone, pojazd należy prowadzić powoli. Jeśli dadzą się słyszeć dźwięki świadczące o tym, że łańcuchy stykają się z nadwoziem lub podwoziem, należy zatrzymać samochód i zacisnąć je. Jeśli łańcuchy wciąż stykają się z elementami pojazdu, należy zmniejszać prędkość, aż łańcuchy przestaną uderzać w samochód.

Łańcuchy należy zdjąć jak tylko rozpocznie się jazdę po oczyszczonej drodze.

### **OSTRZEŻENIE**

#### Zakładanie łańcuchów śniegowych

Aby założyć łańcuchy śniegowe, należy zatrzymać pojazd na płaskim podłożu, z dala od ruchu drogowego. Włączyć światła awaryjne pojazdu i umieścić za nim trójkąt ostrzegawczy, jeśli jest on dostępny. Zanim rozpocznie się instalowanie łańcuchów śniegowych dźwignię zmiany biegów należy zawsze umieścić w położeniu P (Postój), zaciągnąć hamulec postojowy i wyłączyć silnik.

### OSTRZEŻENIE

#### Łańcuchy śniegowe

- Użycie łańcuchów śniegowych może mieć negatywny wpływ na prowadzenie pojazdu.
- Pojazdu nie należy prowadzić szybciej niż 30 km/h (20 mil/h) lub z prędkością większą, niż zalecana przez producenta, którakolwiek z tych wartości okaże się mniejsza.
- Pojazd należy prowadzić ostrożnie i unikać wybojów, dziur, ostrych skrętów i innych zagrożeń drogowych, które mogą powodować podskakiwanie pojazdu.
- Należy unikać ostrych zakrętów lub hamowania z zablokowanymi kołami.

### OSTROŻNIE

- Łańcuchy o niewłaściwym rozmiarze lub niepoprawnie założone mogą uszkodzić linki hamulcowe pojazdu, zawieszenie, nadwozie oraz koła.
- Za każdym razem, kiedy da się usłyszeć, że łańcuchy uderzają w samochód, należy zatrzymać się i zacisnąć je.

## URZĄDZENIE PRZYTRZYMUJĄCE DLA DZIECI (CRS) (POLISH)

Nasze zalecenie: Dzieci  
wzimy zawsze z tyłu

### OSTRZEŻENIE

Zawsze przypinać dzieci jadące w pojeździe we właściwy sposób. Dzieci w każdym wieku są bezpieczniejsze podczas jazdy na tylnych siedzeniach. Nigdy nie montować urządzenia przytrzymującego dla dzieci zwróconego tyłem do kierunku jazdy na przednim siedzeniu pasażera, jeśli nie wyłączono poduszki powietrznej pasażera.

## Odpowiedniość każdego miejsca siedzącego dla urządzeń przytrzymujących dla dzieci ISOFIX zgodnie z regulacjami ECE

Grupa wagowa	Klasa wielkości	Mocowanie	Pozycje ISOFIX w pojeździe			
			Pasażer z przodu	Tyłne zewnętrzne (po stronie kierowcy)	Tyłne zewnętrzne (po stronie pasażera)	Tyłne na środku
Gondola wózka	F	ISO/L1	-	X	X	-
	G	ISO/L2	-	X	X	-
0 : DO 10kg	E	ISO/R1	-	IL	IL	-
0+ : DO 13kg	E	ISO/R1	-	IL	IL	-
	D	ISO/R2	-	IL	IL	-
	C	ISO/R3	-	IL	IL	-
I : od 9 do 18 kg	D	ISO/R2	-	IL	IL	-
	C	ISO/R3	-	IL	IL	-
	B	ISO/F2	-	IUF + IL	IUF + IL	-
	B1	ISO/F2X	-	IUF + IL	IUF + IL	-
	A	ISO/F3	-	IUF + IL	IUF + IL	-

IUF = odpowiednie dla urządzeń przytrzymujących dla dzieci ISOFIX zwróconych przodem do kierunku jazdy kategorii uniwersalnej, dopuszczonych do stosowania w grupie wagowej.

IL = odpowiednie dla danych urządzeń przytrzymujących dla dzieci ISOFIX wymienionych na liście. Te urządzenia przytrzymujące dla dzieci ISOFIX należą do kategorii „tylko do niektórych pojazdów”, „ograniczone” lub „półuniwersalne”.

X = pozycja ISOFIX nieodpowiednia dla urządzenia przytrzymującego dla dzieci ISOFIX w tej grupie wagowej i/lub w tej klasie wielkości.

\* Zarówno ISO/R2, jak i ISO/R3 można ustawić tylko w najbardziej wysuniętej do przodu pozycji siedzenia pasażera.

\* Klasy wielkości i mocowania urządzeń przytrzymujących dla dzieci ISOFIX

A - ISO/F3: Urządzenie przytrzymujące o pełnej wysokości, zwrócone przodem do kierunku jazdy, dla małych dzieci (wysokość 720 mm)

B - ISO/F2: Urządzenie przytrzymujące o zmniejszonej wysokości, zwrócone przodem do kierunku jazdy, dla małych dzieci (wysokość 650 mm)

B1 - ISO/F2X: Urządzenie przytrzymujące o zmniejszonej wysokości, druga wersja powierzchni tylnej, zwrócone przodem do kierunku jazdy, dla małych dzieci (650 mm)

C - ISO/R3: Urządzenie przytrzymujące o pełnej wielkości, zwrócone tyłem do kierunku jazdy, dla małych dzieci



D - ISO/R2: Urządzenie przytrzymujące o zmniejszonej wielkości, zwrócone tyłem do kierunku jazdy, dla małych dzieci

E - ISO/R1: Urządzenie przytrzymujące dla niemowląt, zwrócone tyłem do kierunku jazdy

F - ISO/L1: Urządzenie przytrzymujące dla dzieci, zwrócone bokiem w lewo do kierunku jazdy (gondola)

G - ISO/L2: Urządzenie przytrzymujące dla dzieci, zwrócone bokiem w prawo do kierunku jazdy (gondola)

***Odpowiedniość każdego miejsca siedzącego dla urządzeń przytrzymujących z pasami dla kategorii „uniwersalnej” zgodnie z regulacjami ECE***

Grupa wagowa		Miejsce siedzące			
		Pasażer z przodu, na zewnątrz	Drugi rząd		
			Lewe zewnętrzny	Środek (PAS 3-PUNKTOWY)	Prawe zewnętrzne
Grupa 0 (0 – 9 miesięcy)	do 10 kg	U*	U	U	U
Grupa 0+ (0 – 2 lata)	do 13kg	U*	U	U	U
Grupa I (9 miesięcy – 4 lata)	od 9 do 18 kg	U*	U	U	U
Grupa II (od 15 do 25 kg)	od 15 do 25kg	U*	U	U	U
Grupa III (od 22 do 36kg)	od 22 do 36kg	U*	U	U	U

U : Odpowiednie dla urządzeń przytrzymujących dla dzieci w kategorii „uniwersalne”, dopuszczonych do stosowania w tej grupie wagowej

U\* : Odpowiednie dla urządzeń przytrzymujących dla dzieci w kategorii „uniwersalne”, z oparciem dostosowanym do najbardziej wyprostowanej pozycji

**Urządzenia przytrzymujące dla dzieci i-Size zgodnie z regulacjami ECE**

Grupa wagowa	Miejsce siedzące			
	Pasażer z przodu, na zewnątrz	Drugi rząd		
		Lewe zewnętrzny	Środek	Prawe zewnętrzne
Urządzenia przytrzymujące dla dzieci i-Size	X	i-U	X	i-U

i-U : Odpowiednie dla urządzeń przytrzymujących dla dzieci i-Size w kategorii „uniwersalne”, skierowane przodem i tyłem do kierunku jazdy

i-UF : Odpowiednie tylko dla urządzeń przytrzymujących dla dzieci i-Size w kategorii „uniwersalne” zwróconych przodem do kierunku jazdy

X : Miejsca siedzące nieodpowiednie dla urządzeń przytrzymujących dla dzieci i-Size



**A**

- Accessing your vehicle .....3-4
  - Immobilizer system .....3-13
  - Remote key .....3-4
  - Smart key .....3-8
- Active hood lift system.....2-70
  - Non-activation situations .....2-71
  - Possible activation situations .....2-70
  - System malfunction.....2-72
- Air bag - supplemental restraint system.....2-50
  - Additional safety precautions .....2-69
  - Air bag warning labels.....2-69
  - Curtain air bags.....2-56
  - Do not install a Child Restraint System
    - on the front passenger seat.....2-62
  - Driver's front air bag .....2-52
  - How does the air bags system operate? .....2-57
  - Passenger's front air bag.....2-52
  - Side air bags .....2-54
  - SRS care.....2-68
  - What to expect after an air bag inflates .....2-61
  - Where are the air bags?.....2-52
  - Why didn't my air bag go off in a collision? .....2-63
- Air cleaner .....7-40
  - Filter replacement .....7-40
- Air conditioner compressor label .....8-16
- Air conditioning system .....8-4
- Anti-lock Brake System (ABS).....5-56
- Appearance care .....7-99
  - Exterior care .....7-99
  - Interior care .....7-105
- Ashtray .....3-171
- Audio (Without Touch Screen).....4-14
  - Getting to know the basic operations .....4-20
  - System layout - control panel .....4-14
  - System layout - steering wheel remote control .....4-16
  - Turning the display on or off.....4-19
  - Turning the system on or off.....4-19
- Audio System Specifications.....4-45
  - Bluetooth.....4-46
  - USB .....4-45
- AUTO HOLD .....5-52
- Automatic climate control system .....3-150
  - Automatic heating and air conditioning .....3-151
  - Manual heating and air conditioning .....3-152
  - System maintenance.....3-160
  - System operation.....3-158
- Automatic transaxle.....5-24
  - Automatic transaxle operation .....5-24
  - Good driving practices .....5-29
  - Parking .....5-29

## B

Battery.....	7-46
Battery capacity label .....	7-48
Battery recharging .....	7-48
For best battery service.....	7-46
Reset items .....	7-49
Before driving .....	5-5
Before entering the vehicle .....	5-5
Before starting .....	5-5
Blind-spot collision warning (BCW) system .....	5-114
BCW .....	5-115
Detecting sensor .....	5-119
Limitations of the system.....	5-120
RCCW (Rear Cross-Traffic Collision Warning) ...	5-117
Bluetooth.....	4-31
Connecting Bluetooth devices .....	4-31
Using a Bluetooth audio device.....	4-34
Using a Bluetooth phone.....	4-36
Brake/clutch fluid .....	7-37
Checking the brake/clutch fluid level.....	7-37
Braking system .....	5-43
Anti-lock Brake System (ABS) .....	5-56
AUTO HOLD .....	5-52
Disc brakes wear indicator .....	5-44
Downhill Brake Control (DBC).....	5-64
Electronic Parking Brake (EPB) .....	5-46
Electronic Stability Control (ESC) .....	5-58

Emergency Stop Signal (ESS) .....	5-66
Good braking practices .....	5-67
Hill-Start Assist Control (HAC).....	5-63
Low Vacuum Assist (LVA).....	5-66
Parking brake (hand type).....	5-44
Power brakes .....	5-43
Vehicle Stability Management .....	5-62
Bulb wattage .....	8-3

## C

Cargo security screen .....	3-180
Center console storage.....	3-168
Child Restraint System (CRS).....	2-38
Installing a Child Restraint System (CRS).....	2-41
Our Recommendation: Children always in the rear .....	2-38
Selecting a Child Restraint System (CRS) .....	2-39
Cigarette lighter .....	3-177
Climate control additional features .....	3-167
Automatic ventilation .....	3-167
Cluster ionizer (Except Europe) .....	3-167
Sunroof inside air recirculation .....	3-167
Climate control air filter .....	7-42
Filter inspection.....	7-42
Filter replacement .....	7-42
Clock.....	3-177
Clothes hanger .....	3-178
Cool box .....	3-169

Cruise control .....5-159  
    Cruise Control operation.....5-159  
Cruise control (With Speed Limit Control).....5-154  
    Cruise Control Operation.....5-154  
Cup holder .....3-171  
Curtain air bags.....2-56

**D**

Declaration of conformity .....4-48, 8-16  
    CE RED for EU .....4-48  
    FCC .....4-49  
    IFETEL for Mexico .....4-50  
Defroster .....3-139  
    Rear window defroster.....3-139  
Dimensions .....8-2  
Door locks .....3-14  
    Auto door lock/unlock features .....3-18  
    Child-protector rear door locks.....3-19  
    Deadlocks .....3-18  
    Operating door locks from inside the vehicle .....3-16  
    Operating door locks from outside the vehicle .....3-14  
Downhill Brake Control (DBC) .....5-64  
Drive Mode Integrated Control System .....5-84  
Driver Assist System .....3-129  
    Parking Distance Warning (Reverse) system .....3-129  
    Parking Distance Warning (Reverse/Forward)  
    system .....3-132  
    Rear View Monitor.....3-136

    Surround View Monitor .....3-137  
Driver attention warning (DAW) system .....5-141  
    Resetting the system .....5-142  
    System malfunction.....5-143  
    System setting and activation .....5-141  
    System standby .....5-143  
Driver’s front air bag.....2-52  
Dual clutch transmission .....5-31  
    Dual clutch transmission operation .....5-31  
    Good driving practices .....5-41  
    LCD display for transmission temperature and  
    warning message.....5-33  
Parking .....5-41

**E**

Electronic Parking Brake (EPB) .....5-46  
Electronic Stability Control (ESC) .....5-58  
Emergency commodity.....6-43  
    Fire extinguisher .....6-43  
    First aid kit .....6-43  
    Tire pressure gauge .....6-43  
    Triangle reflector .....6-43  
Emergency Stop Signal (ESS) .....5-66  
Emission control system.....7-108  
    Crankcase emission control system .....7-108  
    Evaporative emission control system .....7-108  
    Exhaust emission control system .....7-109  
    Selective Catalytic Reduction .....7-113

Engine .....	8-2
Engine compartment .....	1-9, 7-3
Engine coolant .....	7-33
Changing the engine coolant.....	7-36
Checking the engine coolant level.....	7-33
Engine number.....	8-15
Engine oil.....	7-29
Checking the engine oil and filter.....	7-32
Checking the engine oil level (Diesel engine).....	7-30
Checking the engine oil level (Gasoline engine).....	7-29
Explanation of scheduled maintenance items .....	7-26
Exterior features .....	3-42, 3-183
Fuel filler door .....	3-44
Hood.....	3-42
Roof rack .....	3-183
Exterior overview .....	1-2

## F

Flex steering wheel .....	5-82
Floor mat anchor(s) .....	3-178
Fog lamp bulb replacement .....	7-82
Forward collision-avoidance assist (FCA) system - sensor fusion type (front radar + front camera) (Except Middle East).....	5-85
FCA sensor.....	5-90
FCA warning message and system control.....	5-87
Limitations of the system.....	5-94
System malfunction.....	5-92

System setting and activation .....	5-85
Forward collision-avoidance assist (FCA) system - sensor fusion type (front radar + front camera) (For Middle East) .....	5-100
FCA sensor .....	5-105
FCA warning message and system control.....	5-102
Limitations of the system.....	5-109
System malfunction.....	5-107
System setting and activation .....	5-100
Four wheel drive (4WD) .....	5-67
4WD operation .....	5-69
Emergency precautions .....	5-73
Reducing the risk of a rollover .....	5-74
Front air ventilation seat.....	2-22
Front seats.....	2-6
Fuel filler door.....	3-44
Fuel Filter (For Diesel).....	7-39
Draining water from fuel filter .....	7-39
Fuel filter cartridge replacement.....	7-39
Fuel label .....	8-17
Diesel engine.....	8-17
Gasoline engine.....	8-17
Fuses .....	7-62
Fuse/Relay panel description .....	7-67

**G**

Glove box .....3-169  
Gross vehicle weight .....8-7

**H**

Hazard warning flasher.....6-2  
Headlamp and front fog lamp aiming (for Europe) .....7-88  
Headlamp bulb replacement .....7-82  
Headrest .....2-16  
Heated steering wheel .....3-24  
High mounted stop lamp replacement.....7-96  
Hill-Start Assist Control (HAC) .....5-63  
Hood .....3-42  
Horn .....3-24

**I**

If the engine overheats .....6-8  
If the engine will not start .....6-4  
    If the engine doesn't turn over or turns over slowly ..6-4  
    If the engine turns over normally but doesn't start ...6-4  
If you have a flat tire (with spare tire) .....6-17  
    Changing tires .....6-18  
    EC Declaration of conformity for Jack.....6-24  
    Jack and tools .....6-17  
    Jack label.....6-23

If you have a flat tire (with Tire Mobility Kit)  
    - Type A .....6-25  
        Checking the tire inflation pressure .....6-30  
        Components of the Tire Mobility Kit .....6-27  
        Distributing the sealant .....6-30  
        Introduction .....6-25  
        Notes on the safe use of the Tire Mobility Kit .....6-26  
        Using the Tire Mobility Kit .....6-28  
If you have a flat tire (with Tire Mobility Kit)  
    - Type B .....6-32  
        Checking the tire inflation pressure .....6-37  
        Components of the Tire Mobility Kit .....6-34  
        Distributing the sealant .....6-37  
        Introduction .....6-32  
        Notes on the safe use of the Tire Mobility Kit .....6-33  
        Using the Tire Mobility Kit .....6-35  
Ignition switch .....5-6  
    Engine Start/Stop button .....5-11  
    Key ignition switch .....5-6  
Important safety precautions .....2-2  
    Air bag hazards .....2-2  
    Always wear your seat belt.....2-2  
    Control your speed.....2-3  
    Driver distraction .....2-2  
    Keep your vehicle in safe condition .....2-3  
    Restrain all children .....2-2



In case of an emergency while driving .....	6-2
If the engine stalls at a crossroad or crossing .....	6-3
If the engine stalls while driving .....	6-2
If you have a flat tire while driving .....	6-3
Inside rearview mirror .....	3-25
Instrument cluster .....	3-60
Distance to empty .....	3-68
Gauges.....	3-62
Icy Road Warning Light .....	3-65
Instrument cluster control .....	3-62
Odometer.....	3-67
Transaxle Shift Indicator.....	3-65
Instrument panel overview .....	1-7
Intelligent speed limit warning (ISLW) system .....	5-148
Display .....	5-150
Driver's attention.....	5-153
Limitations of the system .....	5-152
System setting and activation .....	5-149
Interior features.....	3-171
Ashtray .....	3-171
Cargo security screen .....	3-180
Cigarette lighter .....	3-177
Clock .....	3-177
Clothes hanger .....	3-178
Cup holder.....	3-171
Floor mat anchor(s) .....	3-178
Luggage net (holder).....	3-179
Luggage tray .....	3-182

Power outlet .....	3-173
Sunvisor.....	3-172
USB charger .....	3-174
Wireless cellular phone charging system .....	3-175
Interior light bulb replacement.....	7-97
Interior overview .....	1-5
ISG (Idle Stop and Go) system .....	5-76
ISG system malfunction.....	5-80
The battery sensor deactivation .....	5-81
To activate the ISG system .....	5-76
To deactivate the ISG system .....	5-80

## J

Jump starting .....	6-4
---------------------	-----

## L

Lane keeping assist (LKA) system (Except Europe).....	5-131
Limitations of the System.....	5-138
LKA operation.....	5-132
LKA system function change.....	5-140
Warning light and message .....	5-137
Lane keeping assist (LKA) system (For Europe).....	5-122
Limitations of the System.....	5-129
LKA operation.....	5-123
LKA system function change.....	5-130
Warning light and message .....	5-128

LCD Display.....	3-68
LCD display control.....	3-68
LCD modes .....	3-69
Warning messages .....	3-79
License plate light bulb replacement.....	7-96
Light.....	3-110
Exterior lights.....	3-110
Interior lights.....	3-121
Low Beam Assist-Static light .....	3-120
Welcome system .....	3-120
Light bulbs.....	7-81
Headlamp and front fog lamp aiming (for Europe)....	7-88
Headlamp, Low Beam Assist - Static, Position lamp, Turn signal lamp and Fog lamp light bulb replacement .....	7-82
High mounted stop lamp replacement .....	7-96
Interior light bulb replacement .....	7-97
License plate light bulb replacement .....	7-96
Rear combination light bulb replacement.....	7-93
Side repeater lamp replacement .....	7-87
Load and speed capacity tires.....	8-6
Low Beam Assist - Static light bulb replacement .....	7-82
Low Vacuum Assist (LVA).....	5-66
Luggage net (holder) .....	3-179
Luggage tray .....	3-182
Luggage volume .....	8-8

## M

Maintenance services.....	7-6
Owner maintenance precautions .....	7-6
Owner's responsibility.....	7-6
Manual climate control system.....	3-140
Heating and air conditioning.....	3-141
System maintenance.....	3-148
System operation.....	3-145
Manual transaxle.....	5-20
Good driving practices .....	5-22
Manual transaxle operation .....	5-20
Media Player.....	4-24
Using the AUX mode.....	4-30
Using the iPod mode.....	4-27
Using the media player .....	4-24
Using the USB mode .....	4-25
Mirrors .....	3-25
Inside rearview mirror.....	3-25
Outside rearview mirror .....	3-29
Multimedia system .....	4-2
Antenna .....	4-3
Audio / Video / Navigation system (AVN).....	4-5
AUX, USB and iPod® port .....	4-2
Bluetooth® Wireless Technology hands-free .....	4-5
How vehicle audio works .....	4-6
Steering wheel audio control .....	4-4

## O

Outside rearview mirror .....	3-29
Owner maintenance .....	7-7
Owner maintenance schedule .....	7-8

## P

Panorama sunroof .....	3-37
Closing the sunroof.....	3-39
Resetting the sunroof.....	3-41
Sliding the sunroof .....	3-38
Sunroof open warning.....	3-41
Sunshade .....	3-38
Tilting the sunroof .....	3-39
Parking brake.....	7-38
Checking the parking brake .....	7-38
Parking brake (hand type) .....	5-44
Parking Distance Warning (Reverse) system .....	3-129
Parking Distance Warning (Reverse/Forward) system .....	3-132
Passenger's front air bag .....	2-52
Position lamp bulb replacement .....	7-82
Power outlet .....	3-173

## R

Radio.....	4-21
Changing the radio mode.....	4-22
Listening to saved radio stations.....	4-23
Saving radio stations .....	4-23
Scanning for available radio stations.....	4-22
Searching for radio stations .....	4-23
Turning on the radio.....	4-21
Rear combination light bulb replacement .....	7-93
Rear seats.....	2-13
Rear View Monitor .....	3-136
Recommended lubricants and capacities.....	8-9
Recommended engine oil.....	8-12
Recommended sae viscosity number .....	8-12
Refrigerant label .....	8-16
Remote key .....	3-4
Roof rack .....	3-183

## S

Scheduled maintenance services .....	7-10
Maintenance Under Severe Usage and Low Mileage Conditions (Except Europe, For Russia) .....	7-23
Maintenance Under Severe Usage and Low Mileage Conditions (For Europe, Except Russia) .....	7-16
Normal Maintenance Schedule (Except Europe, For Russia) .....	7-18
Normal Maintenance Schedule (For Europe, Except Russia) .....	7-11

Seat belts .....	2-24	Smart Cruise Control Vehicle-to-Vehicle	
Additional seat belt safety precautions .....	2-34	Distance.....	5-173
Care of seat belts.....	2-37	To adjust the sensitivity of Smart Cruise Control .	5-178
Seat belt restraint system .....	2-28	To convert to Cruise Control mode .....	5-179
Seat belt safety precautions.....	2-24	Smart key .....	3-8
Seat belt warning light.....	2-25	Special driving conditions .....	5-184
Seat warmers.....	2-20	Driving at night.....	5-185
Seats.....	2-4	Driving in flooded areas .....	5-186
Front seats .....	2-6	Driving in the rain.....	5-185
Headrest .....	2-16	Hazardous driving conditions .....	5-184
Rear seats .....	2-13	Highway driving .....	5-186
Safety precautions .....	2-5	Reducing the risk of a rollover .....	5-187
Seat warmers and air ventilation seats.....	2-20	Rocking the vehicle.....	5-184
Setup .....	4-42	Smooth cornering.....	5-185
Bluetooth .....	4-43	Speed limit control system .....	5-146
Date/Time.....	4-43	Speed Limit Control Operation.....	5-146
Display .....	4-42	Steering wheel .....	3-22
Sound.....	4-42	Electric power steering (EPS).....	3-22
System.....	4-43	Heated steering wheel .....	3-24
Side air bags .....	2-54	Horn.....	3-24
Side repeater lamp replacement .....	7-87	Tilt steering / Telescope steering .....	3-23
Sliding armrest .....	3-168	Storage compartment.....	3-168
Smart cruise control with stop & go system .....	5-166	Center console storage .....	3-168
Limitations of the system.....	5-179	Cool box .....	3-169
Sensor to detect distance to the vehicle ahead.....	5-176	Glove box.....	3-169
Smart Cruise Control speed.....	5-167	Sliding armrest .....	3-168
Smart Cruise Control Switch .....	5-166	Sunglass holder .....	3-169

Sunglass holder .....	3-169
Sunvisor .....	3-172
Surround View Monitor .....	3-137
System Status Icons .....	4-44

## T

Tailgate .....	3-47
Non-power tailgate .....	3-47
Power tailgate .....	3-49
Smart tailgate .....	3-56
Theft-alarm system .....	3-20
Tire Pressure Monitoring System (TPMS).....	6-10
Changing a tire with TPMS .....	6-14
Check tire pressure.....	6-10
Low tire pressure position telltale and tire pressure telltale.....	6-12
Low tire pressure telltale.....	6-12
Tire pressure monitoring system.....	6-11
TPMS (Tire Pressure Monitoring System) malfunction indicator.....	6-13
Tire specification and pressure label.....	8-15
Tires and wheels.....	7-50, 8-5
Checking tire inflation pressure.....	7-52
Low aspect ratio tire .....	7-61
Recommended cold tire inflation pressures.....	7-50
Tire care .....	7-50
Tire maintenance .....	7-56
Tire replacement.....	7-54

Tire rotation.....	7-53
Tire sidewall labeling.....	7-56
Tire traction.....	7-56
Wheel alignment and tire balance.....	7-54
Wheel replacement .....	7-56
Towing .....	6-39
Emergency towing .....	6-41
Removable towing hook .....	6-40
Towing service.....	6-39
Trademarks .....	4-47
Trailer towing (For Europe).....	5-193
Driving with a trailer.....	5-199
If you decide to pull a trailer?.....	5-194
Maintenance when towing a trailer.....	5-203
Trailer towing equipment.....	5-198
Trip computer .....	3-87
Trip modes .....	3-87
Turn signal lamp bulb replacement .....	7-82

**U**

USB charger .....3-174

**V**

Vehicle certification label .....8-14  
Vehicle identification number (VIN).....8-14  
Vehicle Stability Management.....5-62  
Vehicle weight .....5-204  
    Overloading.....5-204

**W**

Warning and indicator lights .....3-93  
    Indicator lights .....3-104  
    Warning lights .....3-93  
Washer fluid.....7-38  
    Checking the washer fluid level .....7-38  
Windows .....3-32  
    Power windows .....3-32  
Windshield defrosting and defogging .....3-163  
    Automatic climate control system .....3-164  
    Defogging logic .....3-165  
    Manual climate control system .....3-163  
Winter driving.....5-188  
    Snow or icy conditions .....5-188  
    Winter Precautions .....5-190

Wiper blades .....7-43  
    Blade inspection .....7-43  
    Blade replacement .....7-43  
Wipers and washers .....3-125  
    Rear window wiper and washer switch .....3-128  
    Windshield washers .....3-127  
    Windshield wipers .....3-126  
Wireless cellular phone charging system .....3-175