

SANTAFE

Plug-in hybrid

Emergency Response Guide

Contents

Introduction	1
SANTAFE Plug in Hybrid Identification	2
- Identifying a Hyundai Plug in Hybrid vehicle.....	2
SANTAFE Plug in Hybrid main systems	3
- Vehicle Components Location	3
- Airbag system (SRS : Supplemental Restraint System)	5
Emergency procedures	6
- Initial response: Identify, Immobilize and Disable	6
- Extraction Operations	14
- Submersion	15
- Vehicle Fire	17
- High-Voltage Battery Damage and Fluid Leaks	18
Roadside Assistance	
- Towing	19
- To Jump Start the Car	20

Document Purpose

The purpose of this document is to familiarize emergency responders and the towing/roadside assistance industry with the proper methods to handle the Hyundai SANTAFE Plug in Hybrid in an emergency situation. This guide offers a basic overview of key vehicle systems and provides instructions for dealing with the different types of situations encountered by emergency responders. The emergency response procedures for this vehicle are somewhat similar to a conventional vehicle with additional information provided on dealing with the high-voltage electrical system.

Vehicle Description

The HYUNDAI Plug-in Hybrid Electric Vehicle (PHEV) shares the characteristics of both a conventional hybrid electric vehicle and an all-electric vehicle. When used as a conventional hybrid electric vehicle, the HEV computer selectively operates between the engine and the electric motor or even both at the same time. When it is operating in the electric vehicle mode, the vehicle is driven only using the electric motor over a certain distance until the hybrid battery becomes low. The driving distance in EV mode depends on customer driving style and road conditions. Aggressive driving maneuvers may at times temporarily enable the engine to operate for maximum power. The hybrid battery can be fully charged by connecting a plug to an external electric power source.



SANTAFE Plug-in Hybrid Identification

VIN number

The Vehicle Identification Number (VIN) as shown in the below drawing is punched on the floor under the passenger seat. The letter 2 in the 8th character of the VIN indicates that it is a hybrid with 1.6 gasoline engine.

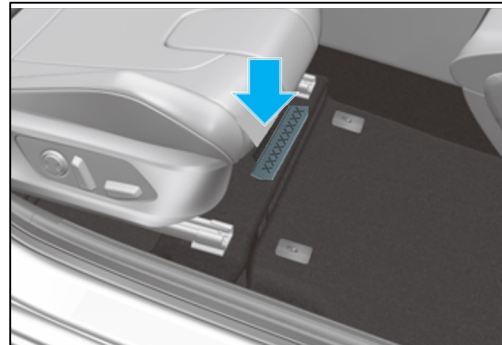

Engine Compartment and underside

The SANTAFE Plug-in Hybrid has a plastic air cleaner assembly with "HYBRID" clearly shown on it.



Additionally, there are orange colored high-voltage electrical cables in the engine compartment and underside.



Vehicle exterior

The SANTAFE Plug-in Hybrid has an exterior charging port at the rear right side. (Opposite to the fuel tank filler-rear left side)

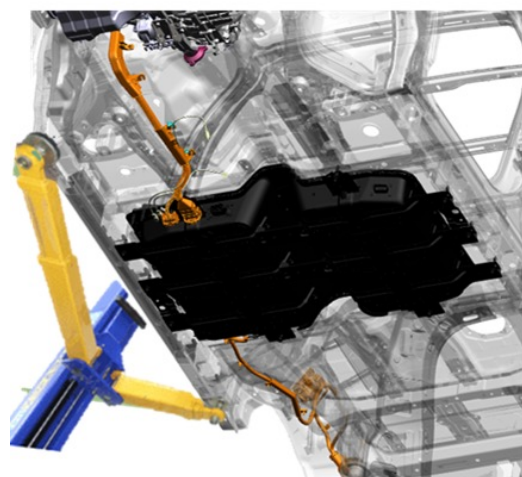
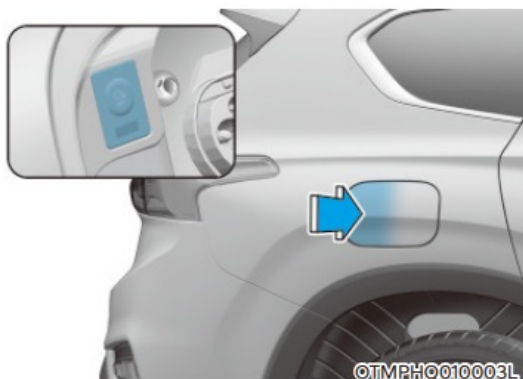

Vehicle Components Location

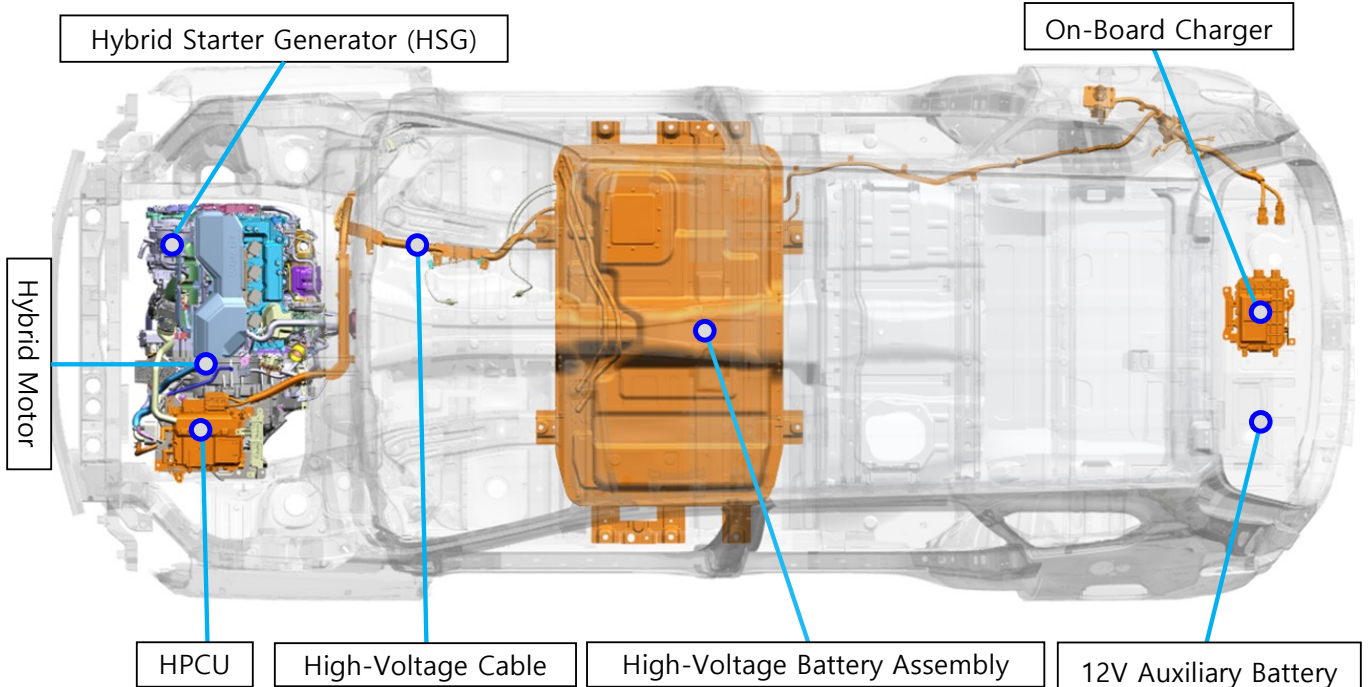

HPCU	Hybrid Power Control Unit
Motor	When current flows through the coil. It generates a rotating magnetic field and generates motor torque.
H.V. Battery	Supplies electric energy to traction motor and stores generated electric energy .
H.V. Cable	The high-voltage cabling is orange per the SAE standard.
On-Board Charger	The equipment that charges the high voltage battery using the 110-220V AC power.

⚠ WARNING Electrocutation Risk!

- Never cut or disconnect the high voltage orange cabling and connectors without first disabling the system by removing the safety plug.
- Exposed cables or wires may be visible inside or outside the vehicle. Never touch the wires, cables, connectors, or any electric components before disabling the system, to prevent injury or death due to electrical shock.

Failure to follow these instructions can lead to death by electrical shock.

Vehicle Components

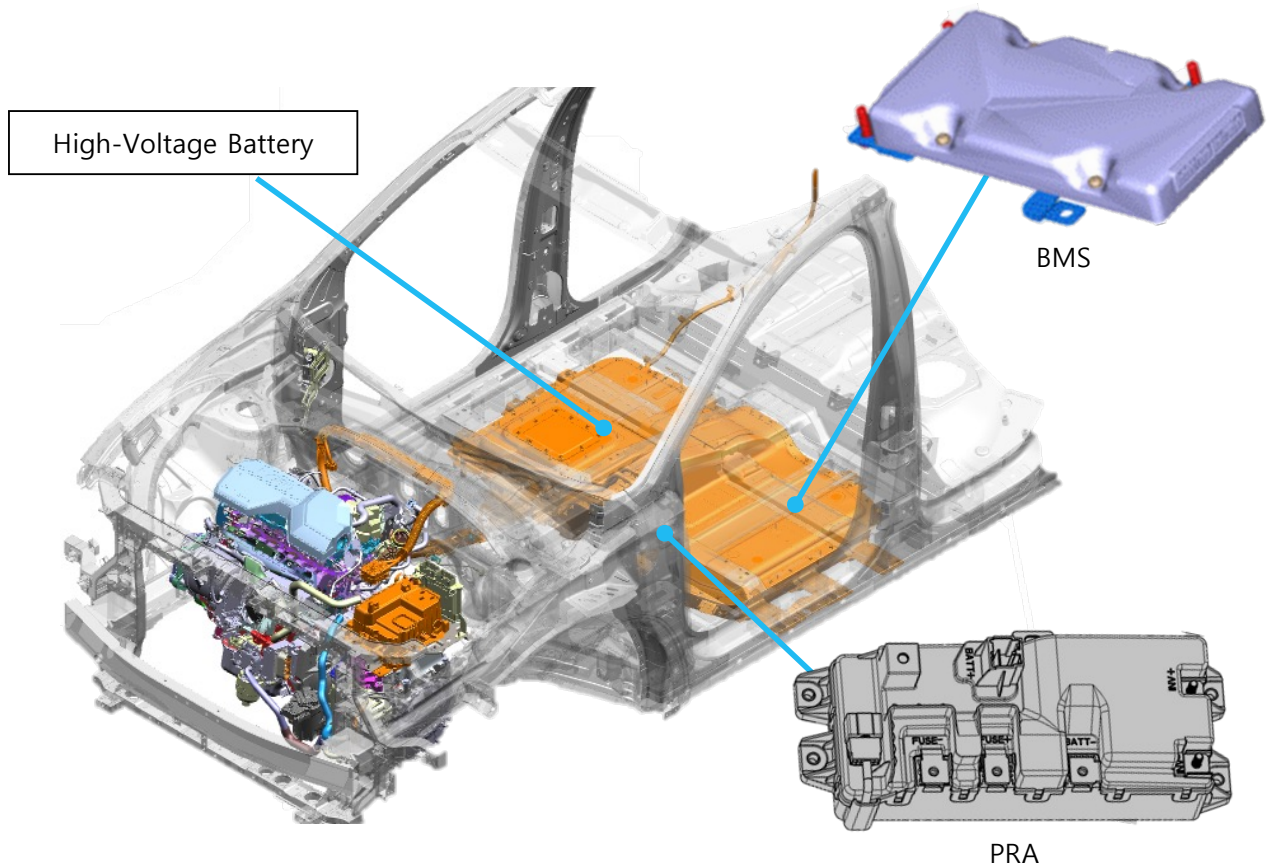

High-Voltage (HV) Battery

The High-Voltage battery is located below the rear seat.

BMS(Battery Management System)

The BMS is located inside the High-Voltage Battery assembly and measures several parameters to maintain the optimal performance of the High-Voltage Battery.

In addition, if a system fault occurs, the BMS turns off the PRA to protect the system.

PRA(Power Relay Assembly)

The PRA is located inside the High-Voltage Battery Pack Assembly and controls the high-voltage power circuit between the High-Voltage Battery and the Hybrid Power Control Unit.

12V Auxiliary Battery

The 12V auxiliary battery is located below the luggage mat.

Airbag system (SRS : Supplemental Restraint System)

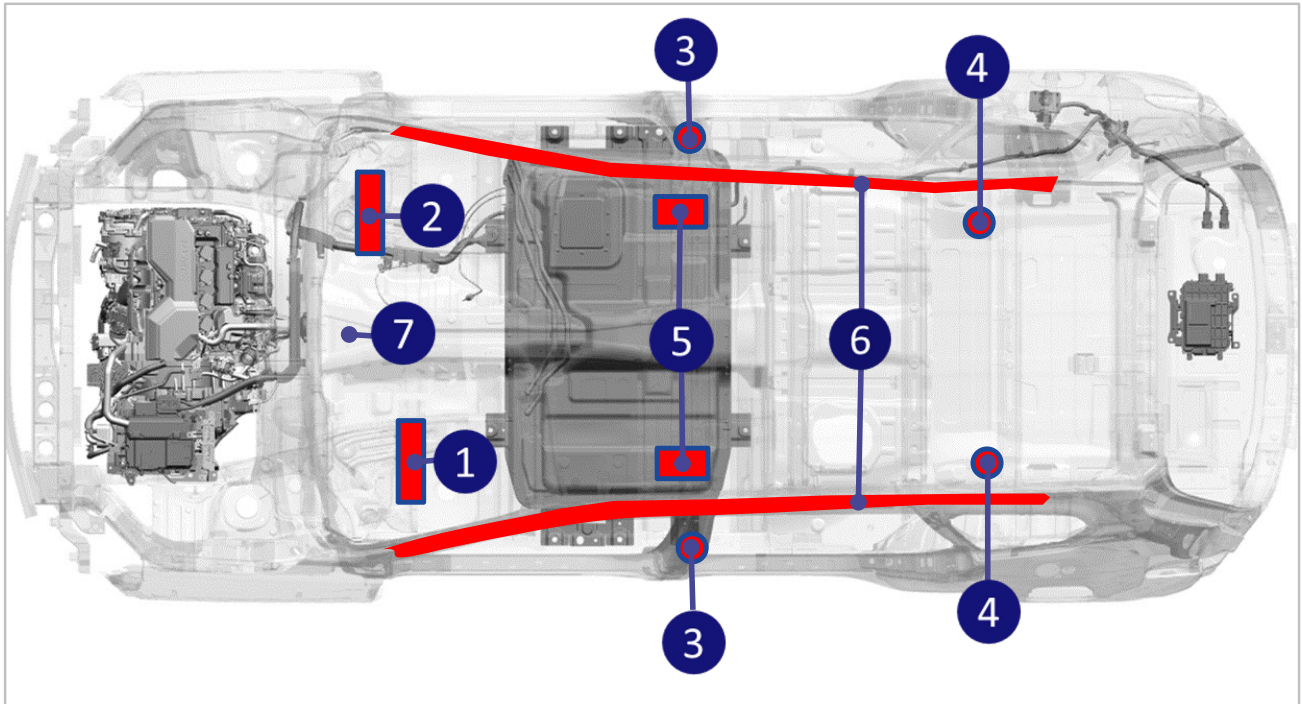

- | | |
|--|---|
| 1. Driver's front airbag | 5. Side Airbag (Driver, Passenger side) |
| 2. Passenger's front airbag | 6. Curtain Airbag (Driver, Passenger side) |
| 3. Front Seat Belt Pretensioner (FBPT) | 7. Supplemental Restraint System Control Module (SRSCM) |
| 4. Rear Seat Belt Pretensioner (RBPT) | |

⚠ WARNING

- Do not cut through any component.
- SRS components may remain powered and active for up to 3 minutes after the 12V electrical system is shut off or disabled. Disconnect the battery negative cable and wait for at least 3 minutes before beginning work.

Failure to follow any of these instructions may result in serious injury or death from accidental deployment of the airbag system.

Initial Response

The following procedures should be used whenever you are dealing with a SANTAFE Plug-in Hybrid at an emergency scene. All other operations should be consistent with your department's standard operating procedures or guides. Hybrid vehicles damaged by a crash may have compromised high voltage safety systems and present a potential high voltage electrical shock hazard. Exercise caution and wear appropriate personal protective equipment (PPE) safety gear, including high voltage safety gloves and boots. Remove all metallic jewelry, including watches and rings.

Identify

When dealing with a SANTAFE at the scene of an accident, emergency responders should always assume that it is a hybrid model until it can be proven otherwise using the identification features outlined in this ERG. External badging will usually be the first clue but it can often be hidden by damage caused in a crash. Always be sure to inspect multiple sides of the vehicle as well as using the clues found under the hood and in the interior of the vehicle.



Immobilize

The next step is to immobilize the vehicle to prevent any accidental movement that can endanger the emergency response personnel and any crash victims. Since the SANTAFE Plug-in Hybrid has the ability to shut down the gasoline engine when it is not needed, there will be instances where the vehicle appears to be off because of the absence of engine noise. When in its "ready" mode, the vehicle can move almost silently using the electric motor alone. Responders should approach the vehicle from the sides and stay away from the front or rear as they are both potential paths of travel. Instructions for immobilizing the vehicle are shown below.



Push the shift button to park (P)



Engage Parking Brake



Chock the Wheels

Disable

The final step in the initial response process, conducted after the vehicle is secured to prevent movement, is to disable the vehicle, its SRS components and the high voltage electrical system. To prevent current flow through the system, use one of the following procedures to disable the vehicle.

I . Disabling the system – Smart Key System and “POWER” START/STOP BUTTON

1. Check the status of the READY light on the instrument panel. If the READY light is illuminated, the vehicle is on.

(Refer to page 5)

- a) If the READY light is NOT illuminated, the vehicle is off, Do not push the “POWER” START/STOP button because the vehicle may restart.

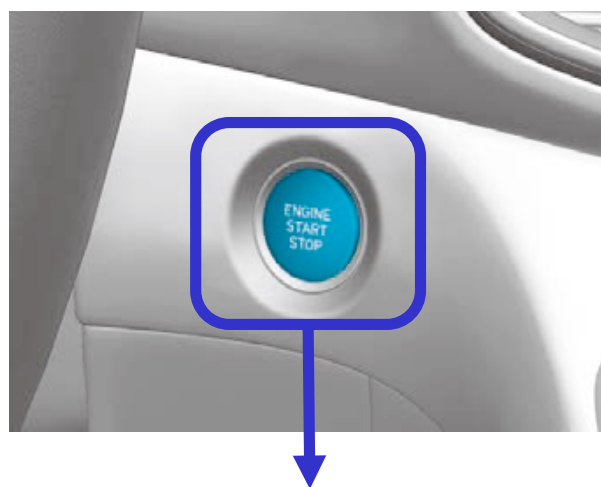

“POWER” START/STOP Button

- b) To turn off the system, put the shift lever in the P (Park) position and press the POWER button beside a shift lever.

Without depressing the brake pedal

Pressing POWER button	Button Position	Vehicle condition
	OFF	Off
One time	ACC	Electrical accessories are operational.
Two times	ON	The warning lights can be checked before the vehicle is started.
Three times	OFF	Off

Depressing the brake pedal while a shift lever is in the P (Park)

Pressing POWER button	Button Position	Vehicle condition
	OFF	Off
One time	-	Ready to drive

Emergency procedures

2. Before disconnecting the 12V battery, move the smart key at least 2 meters away from the vehicle to prevent accidental restart.



Smart Key

3. Separate the negative (-) 12V battery cable (A), located at the luggage room, to further prevent the risk of accidental restart.



3-1. Remove the luggage mat (A).



3-2. Remove the 12V battery service cover (A).



3-3. Turn the ignition switch OFF and disconnect the auxiliary 12V battery negative (-) terminal (A).

NOTICE

If necessary, lower the windows, unlock the doors and open the trunk as required, before disconnecting the 12V battery. Once the 12V battery is disconnected, power controls will not operate.

4. Use the following procedure to remove the service interlock connector and disable the high voltage battery:



a. Disconnect the service interlock connector(A) located at the engine room right side.

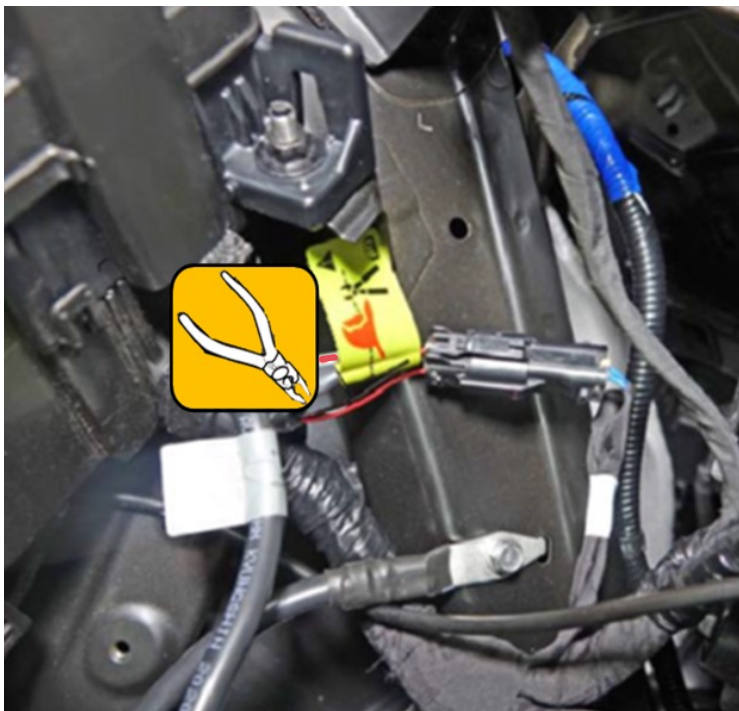

b. If the Service Interlock connector cannot be disconnected, cut the wire attached the yellow warning label.

⚠ WARNING

Wait for more than 3 minutes so that the capacitor in the high voltage system can be fully discharged.

II. Disabling the system – IG Relay Removal (Alternate Method)

1. Open the hood.
2. Remove the motor compartment fuse box cover.

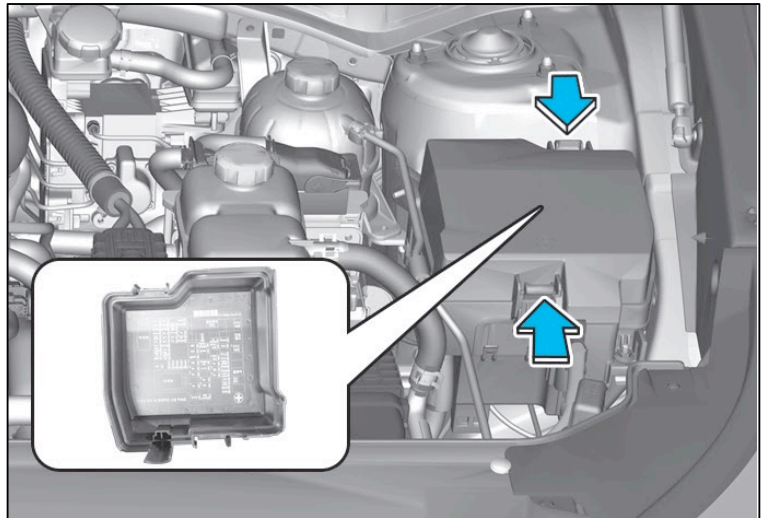

3. In the event the vehicle cannot be disabled using the "Power" START/STOP Button, pull the IG1, IG2 fuses or relays from the engine compartment room fuse box. If the IG fuses cannot be located, pull out all the fuses and relays in the fuse box.

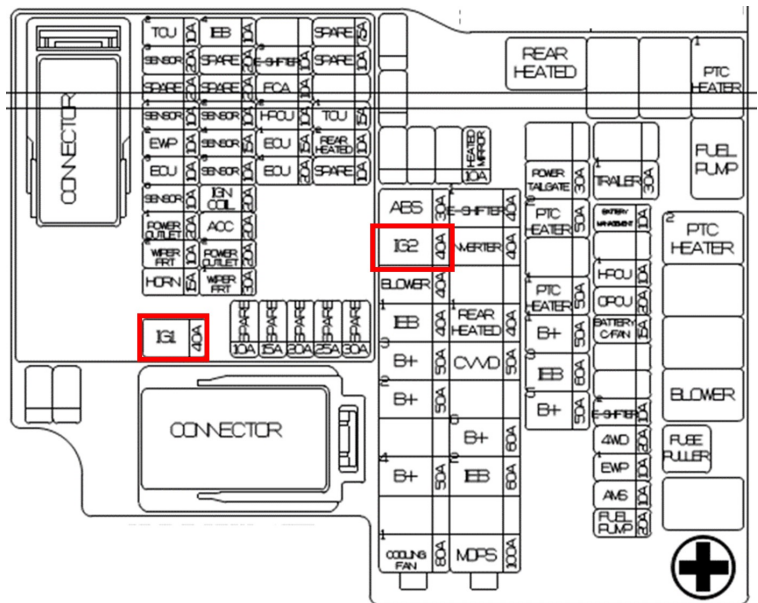

Engine compartment fuse box

II. Disabling the system – IG Relay Removal (Alternate Method)

4. Separate the negative (-) 12V battery cable (A), located at the luggage room, to further prevent the risk of accidental restart., to further prevent the risk of accidental restart.



4-1. Remove the luggage mat (A).



4-2. Remove the 12V battery service cover (A).

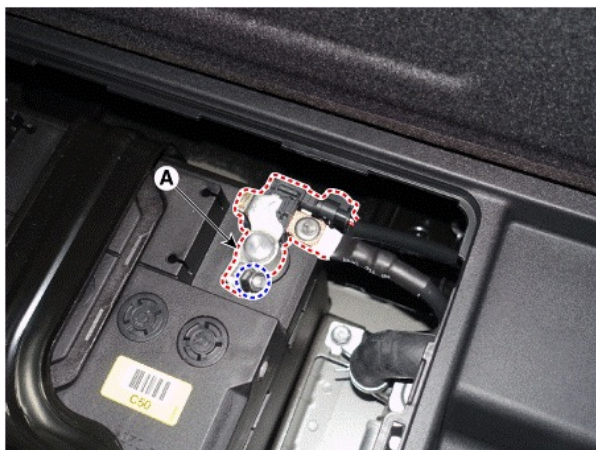

4-3. Turn the ignition switch OFF and disconnect the auxiliary 12V battery negative (-) terminal (A).

NOTICE

If necessary, lower the windows, unlock the doors and open the trunk as required, before disconnecting the 12V battery. Once the 12V battery is disconnected, power controls will not operate.

5. Use the following procedure to remove the service interlock connector and disable the high voltage battery:

- a) Remove the service interlock connector (A) located at the engine room right side.
- a) If the Service Interlock cannot be disconnected, cut the wire attached the yellow warning label.

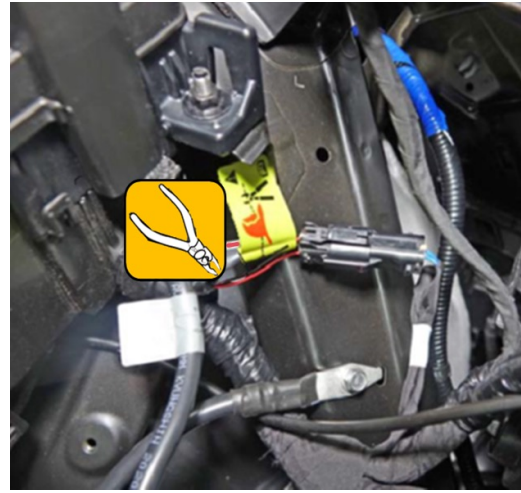

If both methods of disabling system are unsuccessful, the vehicle is not secured from accidental deployment of airbags and electric shock from high-voltage components.

⚠ WARNING Electrocutation Risk!

- Before engaging in emergency response procedures, ensure the vehicle is disabled and wait for more than 3 minutes to allow the capacitor in the high voltage system to discharge to avoid electrocution.
- Exposed cables or wires may be visible inside or outside the vehicle. To prevent injury or death due to electrical shock, never touch the wires or cables before disabling the system, to prevent injury or death due to electrical shock.

Failure to follow any of these instructions may result in serious injury or death by electrocution.

⚠ WARNING Explosive Risk!

- Do not cut through any component.
- SRS components may remain powered and active for up to 3 minutes after the 12V electrical system is shut off or disabled. Disconnect the battery negative cable and wait for at least 3 minutes before beginning work.

Failure to follow any of these instructions may result in serious injury or death from accidental deployment of the airbag system.

Extrication Operations

The extrication operations for the SANTA FE Plug-in Hybrid are similar to the conventional vehicle. However, the first responder should pay special attention when they extract occupants in the vehicle. Before extrication operations, the first responders should carry out "Initial Response: Identify, Immobilize and Disable" procedure section in page 17 to 21.

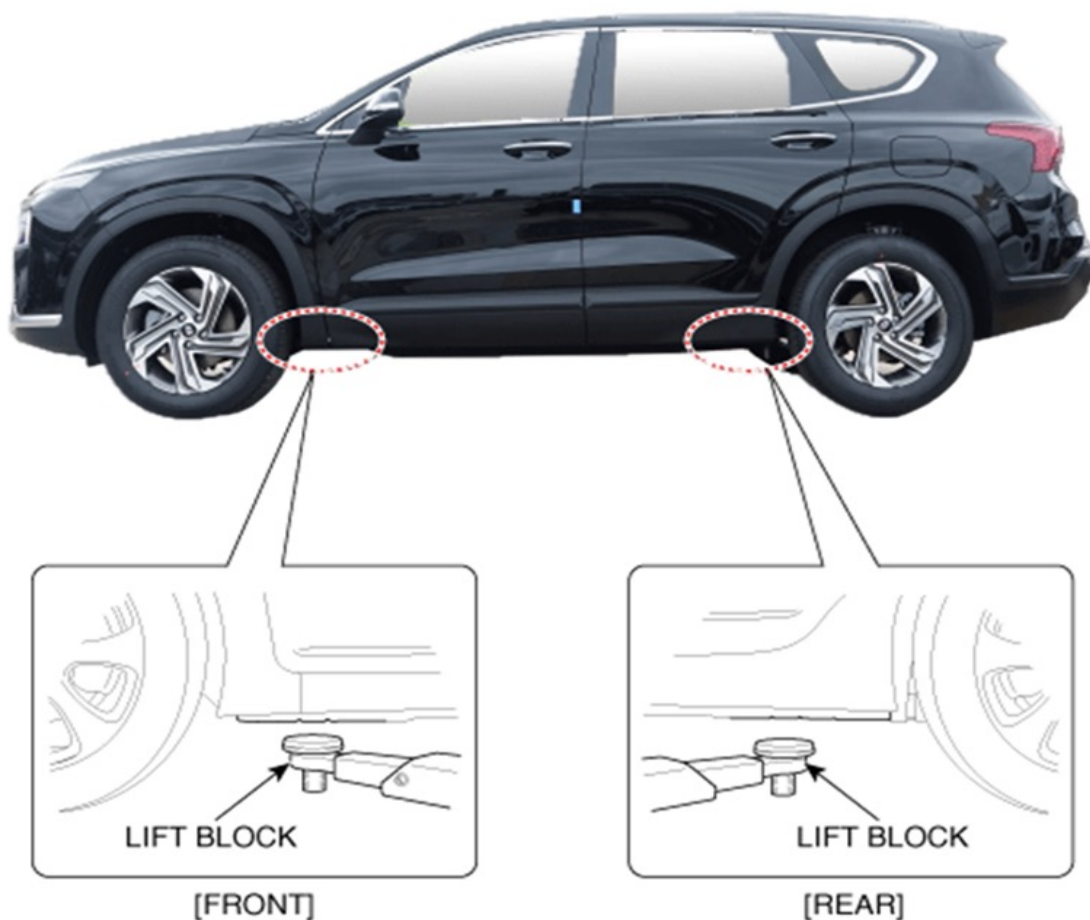

Vehicle Stabilization

Use standard stabilization (cribbing) points, as shown. Always be sure to connect to a structural member of the vehicle and avoid placing cribbing under high voltage cables, fuel lines and other areas not normally considered acceptable.

Emergency procedures

Extrication procedure

When responding to an incident involving a SANTAFE Plug-in Hybrid, we recommend that the first responders follow their organization's standard operating procedures for assessing and dealing with vehicle emergencies. When the first responders cut the vehicle, they should always pay special attention to airbag system, orange colored high voltage cables and other high voltage components as below image to avoid damage to parts which may increase the risks of explosion.

Yellow marked zone is Hot stamped steel. So this zone can not be cut with general tools.

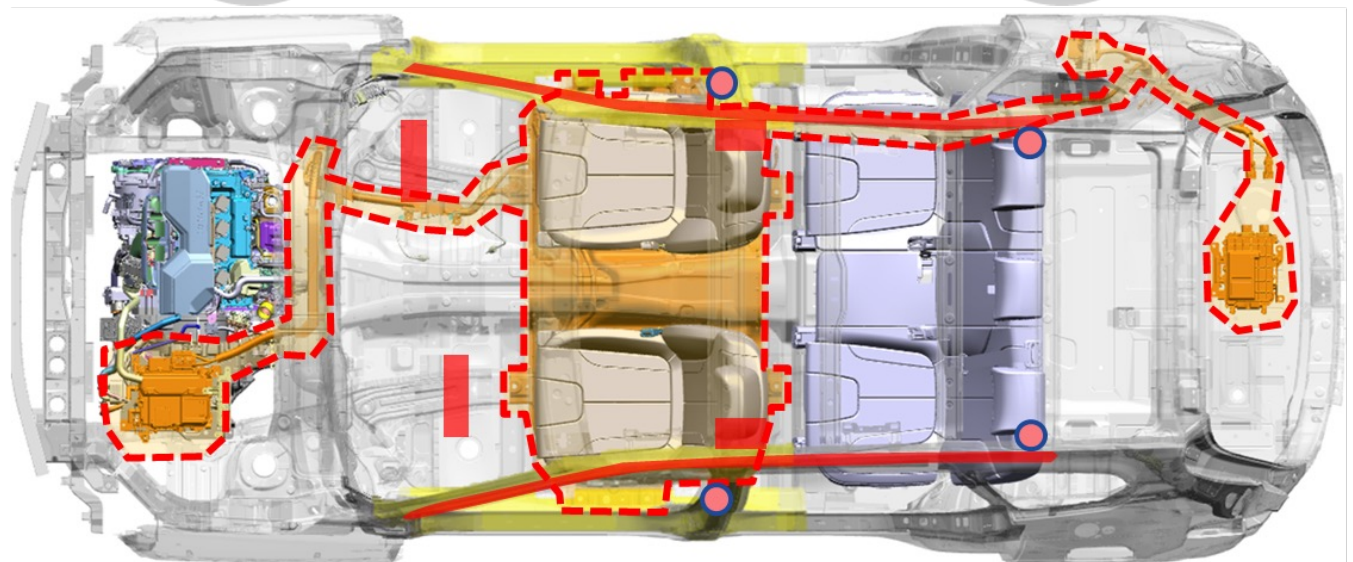
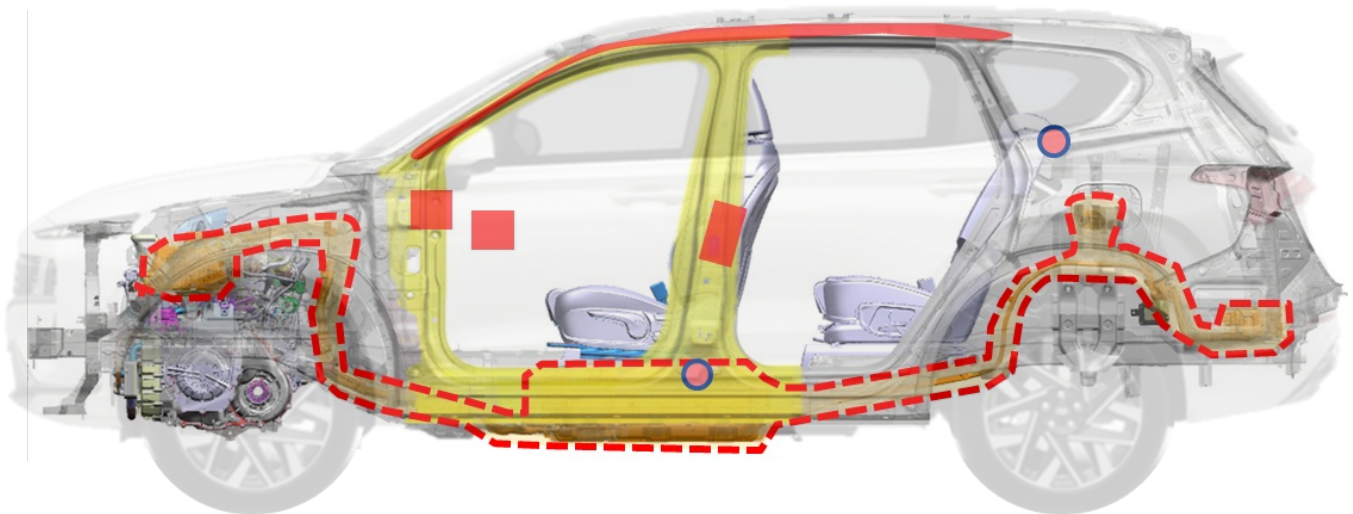

Airbag

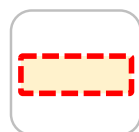

High Voltage Cables

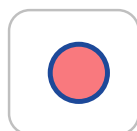

Belt pre-tensioner



Ultra High Strength Steel (hot stamped steel)

Submersion

Some emergency responses can involve a submerged vehicle. A SANTAFE Plug-in Hybrid that is submerged does not have high-voltage component on the vehicle's body or framework. It is safe to touch the vehicle's body or framework if there is no severe damage to the vehicle, whether it is in water or on land.

In the event the vehicle is submerged or partially submerged, remove the vehicle from the water before attempting to disable the vehicle. Drain the water from the vehicle. Use one of the methods described in sections of page 8 to 13 to disable the vehicle.

WARNING

- If severe damage causes high-voltage components to become exposed, responders should take appropriate precautions and wear appropriate insulated personal protective equipment.
- Do not attempt to remove a safety plug while in the water

Failure to follow any of these instructions may result in serious injury or death by electrocution.

Vehicle Fire

After Initial Emergency Response Procedures have been applied, Firefighting Procedures may begin. Hyundai recommends that each response team follow their own department's standard operating procedures for fighting vehicle fires in combination with the SANTAFE Plug-in Hybrid specific details that are covered in this section.

Firefighting Operations

If the high-voltage battery pack is either involved in or at risk of being involved in a fire in a SANTAFE Plug-in Hybrid, strict cautions must be taken while conducting firefighting operations due to following reasons:

- Lithium-ion Polymer batteries contain gel electrolyte that can vent, ignite, and produce sparks when subjected to temperatures above 300°F.
- May burn rapidly with a flare-burning effect.
- Even after the high-voltage battery fire appears to have been extinguished, renewed or delayed fire can occur.
 - Use a thermal imaging camera to ensure the high voltage battery is completely cooled before leaving the incident.
 - Always advise second responders that there is a risk of the battery re-igniting.
 - Fire, submersion or a collision that has compromised the high voltage battery, always store it in an open area with no exposures within 50 feet.
- A burning battery could release hydrogen fluoride, carbon monoxide, and carbon dioxide gasses. Use NIOSH/MSHA approved full-face self-contained breathing apparatus (SCBA) with full protective gear.

Even if the high-voltage battery pack is not directly involved in a vehicle fire, approach the vehicle very carefully.

Extinguishers

- Small fires that high voltage battery is not involved : Extinguish fires using a ABC extinguisher for an electric fire.
- Fires that the high voltage battery is involved, or the high voltage battery is heating : Extinguish fires using large and sustained amount of water to cool the high voltage battery. Do not extinguish fire with a small amount of water. Firefighters should not hesitate to pour large amounts of water on the vehicle.

High-Voltage Battery Damage and Fluid Leaks

The HV Battery assembly is enclosed in a sturdy metal case that is rigidly mounted to structural components of the vehicle. This construction helps prevent damage to the HV Battery assembly even in severe crashes. This section provides emergency responders with information regarding how to mitigate the severity of a damaged HV Battery assembly or gel electrolyte spill, however unlikely that might be.

- Cease all smoke, spark, flame activity around the vehicle.
- Electrolyte solution is a skin irritant.
- Do not touch or step on the spilled electrolyte.
- If electrolyte leak occurs, wear appropriate solvent resistant PPE and use oil, sand, or a dry cloth to clean up the spilled electrolyte. Be sure to adequately ventilate the area.

WARNING Irritant Substance Risk!

- Internal components of HV Batteries are irritants and sensitizers.
- To avoid contact with these irritants and sensitizers wear positive pressure self- contained breathing apparatus (SCBA) and other personal protective equipment (PPE) designed for use with these types of hazards.

Failure to wear proper SCBA and PPE can result in serious injury or death

- Electrolyte solution is an eye irritant – If contact with eyes, rinse with plenty of water for 15 minutes.
- Electrolyte solution is a skin irritant. Therefore, if there is contact with skin, wash off with soap.
- Electrolyte liquid or fumes that have come into contact with water vapors in the air will create an oxidized substance. This substance may irritate skin and eyes. In these cases, rinse with plenty of water and see a doctor immediately.

- Electrolyte fumes (when inhaled) can cause respiratory irritation and acute intoxication

Move to a well ventilated location for fresh air and wash mouth with water. See a doctor immediately.

Towing

When towing SANTAFE Plug-in Hybrid vehicle, all wheels should be off the ground and not in contact with the road.

If emergency towing is necessary, we recommend having it done by an authorized Hyundai dealer or a commercial tow-truck service. The use of wheel dollies or flatbed is recommended.

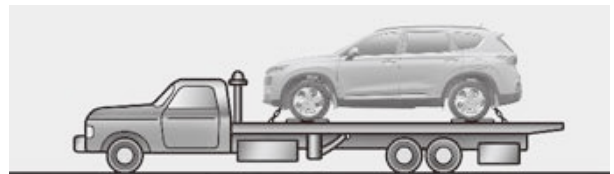

For 2WD type



CAUTION

- Do not tow the vehicle backwards with the front wheels on the ground as this may cause damage to the vehicle.
- Do not tow with sling-type equipment. Use wheel lift or flatbed equipment.
- Never tow the vehicle with the front wheels on the ground (forward or backward), as this may cause damage to the vehicle.

To Jump Start the Car

Jump Starting

If the 12V battery is over discharged to a point that the reset does not work, try to jump-start the vehicle.

1. Position the vehicles close enough that the jumper cables will reach, but do not allow the vehicles to touch.
2. Avoid fans or any moving parts in the engine compartment at all times, even when the vehicles are turned off.
3. Turn off all electrical devices such as radios, lights, air conditioning, etc. Select the shift button to P (Park) and set the parking brakes. Turn both vehicles OFF.

CAUTION

- Do not connect the cables to or near any part that moves when the vehicle is started.
- Do not allow the jumper cables to contact anything except the correct battery terminals or the correct ground.
- Do not lean over the battery when making connections.

4. Connect the jumper cables in the exact sequence shown in the illustration. First connect one jumper cable to the red, positive (+) jumper terminal of your vehicle (1).

5. Connect the other end of the jumper cable to the red, positive (+) battery/jumper terminal of the assisting vehicle (2).

6. Connect the second jumper cable to the black, negative (-) battery/chassis ground of the assisting vehicle (3).

7. Connect the other end of the second jumper cable to the black, negative (-) chassis ground of your vehicle (4). Do not allow the jumper cables to contact anything except the correct battery or jumper terminals or the correct ground.

8. Start the engine of the assisting vehicle and let it run about 2000 rpm for a few minutes.

9. Start your vehicle as soon as possible. After starting vehicle, operate the vehicle safely at least 30 minutes to charge the 12V battery fully. If you do not run the vehicle enough, the battery may not be charged enough.

If the cause of your battery discharging is not apparent, we recommend that the system be checked.

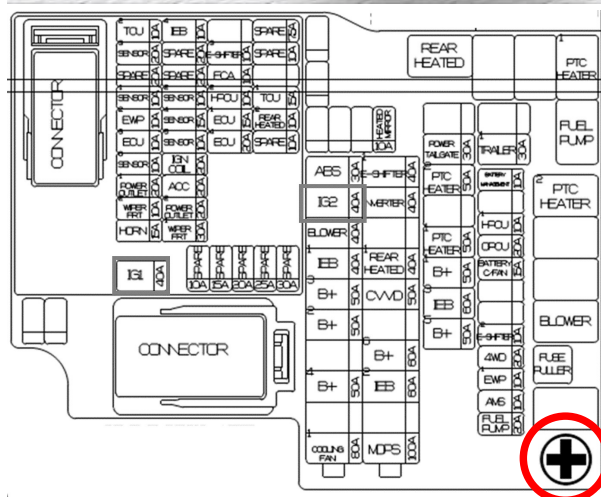
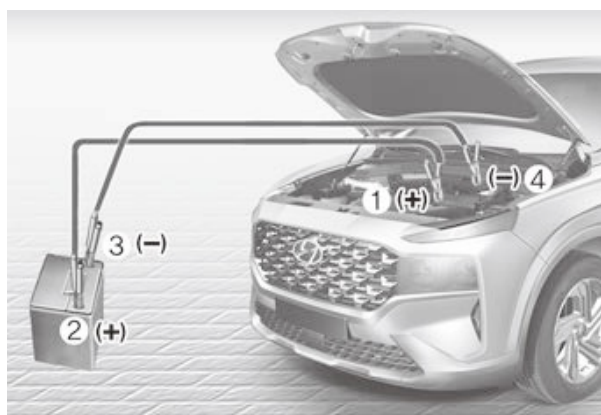

CAUTION

- Do not connect the cables to or near any part that moves when the vehicle is started.
- Do not allow the jumper cables to contact anything except the correct battery terminals or the correct ground.
- Do not lean over the battery when making connections.

